

Butterfly valve with Wafer types

- For open and closed cold and warm water systems
- For switching heat generators or cooling machines on and off

Type overview

Type	DN []	PN []	kvmax [m³/h]
D625N	25	6 / 10 / 16	45
D632N	32	6 / 10 / 16	55
D640N	40	6 / 10 / 16	70
D650N	50	6 / 10 / 16	90
D665N	65	6 / 10 / 16	180
D680N	80	6 / 10 / 16	300
D6100N	100	6 / 10 / 16	580
D6125N	125	6 / 10 / 16	820
D6150N	150	6 / 10 / 16	1600
D6200N	200	6 / 10 / 16	2900
D6250N	250	10 / 16	4400
D6300N	300	10 / 16	7300
D6350N	350	10 / 16	10900
D6400N	400	16	14200
D6450N	450	16	18800
D6500N	500	16	24100
D6600N	600	16	37300
D6700N	700	16	42800

Technical data

Functional data	Media	Cold and warm water, water with glycol up to max. 50% vol.
	Medium temperature	-20...120°C
	Permissible pressure ps	1600 kPa
	Leakage rate	Leakage rate A, tight (EN 12266-1)
	Pipe connectors	DN 25...200: Flange PN 6/PN 10/PN16 (according to ISO 7005-2) DN 250...350: Flange PN 10 / PN 16 (according to ISO 7005-2) DN 400...700: Flange PN 16 (according to ISO 7005-2)
	Angle of rotation	90°
	Installation position	Upright to horizontal (in relation to the stem)
	Suitable connection flange	In accordance with ISO 7005-2 and EN 1092-2
	Maintenance	Maintenance-free
	Materials	Housing
Closing element		1.4301 (stainless steel)
Stem		1.4005 (stainless steel)
Stem seal		O-ring EPDM
Spindle bearing		RPTFE
Seat		EPDM

Safety notes



- The valve has been designed for use in stationary heating, ventilation and air-conditioning systems and is not allowed to be used outside the specified field of application, especially in aircraft or in any other airborne means of transport.
- Only authorised specialists may carry out installation. All applicable legal or institutional installation regulations must be complied during installation.
- The valve does not contain any parts that can be replaced or repaired by the user.
- The valve may not be disposed of as household refuse. All locally valid regulations and requirements must be observed.
- When determining the flow rate characteristic of controlled devices, the recognised directives must be observed.
- The damper must be opened and closed slowly in order to avoid hydraulic shocks in the pipe system.

Product features

Principle of operation The butterfly valve is opened or closed completely by an open-close rotary actuator. Continuous rotary actuators are connected by a commercially available controller and move the valve to any position desired. The valve disk made of stainless steel is pressed into the soft-sealing EPDM seat by a rotary movement and ensures leakage rate A (tight). The pressure losses are slight in the open position and the kv value is at a maximum.

Manual override Manual throttling or shut-off can be carried out with a lever or a worm gear (see «Accessories»).

- With lever (DN25...150): Adjustable in 10 ratchet steps with position indication (0 = 0° (angle); 9 = 90° (angle))
- With worm gear (DN25...700): steplessly adjustable (self-locking) with position indication.

Accessories

	Description	Type
Electrical accessories	Stem heating flange ISO 5211, F05 (30W)	ZR24-F05
	Description	Type
Mechanical accessories	Worm gear for D6.. butterfly valves, DN25...DN100	ZD6N-S100
	Manual control for D6.. butterfly valves, for DN25...DN100	ZD6N-H100
	Worm gear for D6.. butterfly valves, DN125...DN150	ZD6N-S150
	Manual control for D6.. butterfly valves, for DN125...DN150	ZD6N-H150
	Worm gear for D6.. butterfly valves, DN200	ZD6N-S200
	Worm gear for D6.. butterfly valves, DN250	ZD6N-S250
	Worm gear for D6.. butterfly valves, DN300...DN350	ZD6N-S350
	Worm gear for D6.. butterfly valves, DN400	ZD6N-S400
	Worm gear for D6.. butterfly valves, DN450	ZD6N-S450
	Worm gear for D6.. butterfly valves, DN500	ZD6N-S500
	Worm gear for D6.. butterfly valves, DN600	ZD6N-S600
	Worm gear for D6... butterfly valves, DN700	ZD6N-S700

Installation notes

Recommended installation positions The butterfly valves may be mounted upright to horizontal. The butterfly valves may not be installed in a hanging position i.e. with the spindle pointing downwards.

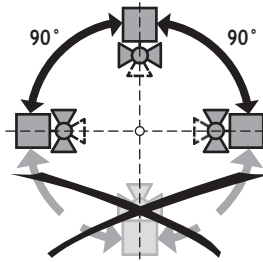

Water quality requirements The water quality requirements specified in VDI 2035 must be adhered to.

Stem heating In cold water applications and warm humid ambient air can cause condensation in the actuators. This can lead to corrosion in the gear box of the actuator and causes a breakdown of it. In such applications, the use of a stem heating is provided. The stem heating must be enabled only when the system is in operation, because it does not have temperature control.

Maintenance Butterfly valves and rotary actuators are maintenance-free. Before any kind of service work is carried out on the actuator, it is essential to isolate the rotary actuator from the power supply (by unplugging the electrical cable). Any pumps in the part of the piping system concerned must also be switched off and the appropriate slide valves closed (allow everything to cool down first if necessary and reduce the system pressure to ambient pressure level). The system must not be returned to service until the butterfly valve and the rotary actuator have been mounted properly in accordance with the instructions and the pipeline has been refilled in the proper manner. To avoid a torque increase during off season shut down, exercise the butterfly valve (full open and close) at least once a month.

Dimensions / Weight

Dimensional drawings

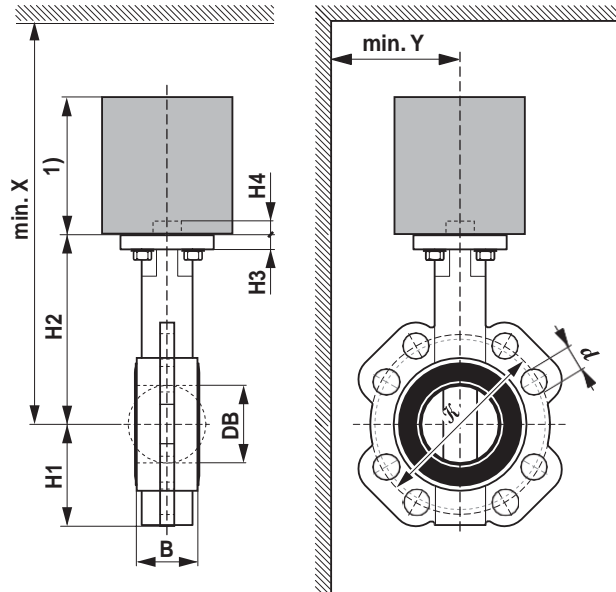

Type	DN []	B [mm]	DB [mm]	H1 [mm]	H2 [mm]	H3 [mm]	H4 [mm]	d (PN6) [mm]	K (PN6) [mm]
D625N	25	32	30	57	86	10	13	4 x 11	75
D632N	32	33	35	60	100	10	13	4 x 14	90
D640N	40	33	42	68	119	10	13	4 x 14	100
D650N	50	43	52	72	133	11	13	4 x 14	110
D665N	65	46	64	81	147	11	13	4 x 14	130
D680N	80	46	78	96	158	11	13	4 x 19	150
D6100N	100	52	103	106	170	11	13	4 x 19	170
D6125N	125	56	122	122	194	15	19	8 x 19	200
D6150N	150	56	155	140	202	15	19	8 x 19	225
D6200N	200	60	202	172	240	15	19	8 x 19	280
D6250N	250	68	250	206	268	15	24		
D6300N	300	78	301	244	316	15	24		
D6350N	350	78	333	267	361	15	24		
D6400N	400	102	391	308	400	20	48		
D6450N	450	114	442	337	422	22	48		
D6500N	500	127	493	359	480	22	48		
D6600N	600	154	594	454	562	25	48		
D6700N	700	165	695	505	624	33	66		

Type	d (PN10) [mm]	K (PN10) [mm]	d (PN16) [mm]	K (PN16) [mm]	X [mm]	Y [mm]	Weight approx. [kg]
D625N	4 x 14	85	4 x 14	85	320	150	1.1
D632N	4 x 19	100	4 x 19	100	340	150	1.5
D640N	4 x 19	110	4 x 19	110	350	160	1.6
D650N	4 x 19	125	4 x 19	125	370	160	2.4
D665N	4 x 19	145	4 x 19	145	380	170	3.0
D680N	8 x 19	160	8 x 19	160	390	180	3.3
D6100N	8 x 19	180	8 x 19	180	410	190	4.0
D6125N	8 x 19	210	8 x 19	210	530	210	6.7
D6150N	8 x 23	240	8 x 23	240	540	220	7.4
D6200N	8 x 23	295	12 x 23	295	580	250	12
D6250N	12 x 23	350	12 x 28	355	630	280	20
D6300N	12 x 23	400	12 x 28	410	680	310	30
D6350N	16 x 23	460	16 x 28	470	730	340	34
D6400N			4 x 31	525	1300	1300	60
D6450N			4 x 31	585	1300	1400	73
D6500N			4 x 33	650	1700	1500	98
D6600N			16 x 37	770	1800	1800	190
D6700N			20 x 37	840	1800	1900	330

Further documentation

- Overview Valve-actuator combinations
- Data sheets for actuators
- Installation instructions for actuators and/or butterfly valves
- General notes for project planning