

Communicative globe valve actuator with emergency control function for 2-way and 3-way globe valves

- Actuating force 2000 N
- Nominal voltage AC/DC 24 V
- Control modulating, communicative DC (0)2...10 V Variable
- Nominal stroke 32 mm
- Conversion of sensor signals
- Design life SuperCaps: 15 years
- Communication via Belimo MP-Bus

Technical data

Electrical data	Nominal voltage	AC/DC 24 V
	Nominal voltage frequency	50/60 Hz
	Nominal voltage range	AC 19.2...28.8 V / DC 21.6...28.8 V
	Power consumption in operation	5 W
	Power consumption in rest position	2 W
	Power consumption for wire sizing	9.5 VA
	Connection supply / control	Terminals with cable 1 m, 4 x 0.75 mm ² (Terminal 4 mm ²)
Parallel operation	Yes (note the performance data)	
Functional data	Actuating force motor	2000 N
	Positioning signal Y	DC 0...10 V
	Positioning signal Y note	Input impedance 100 kΩ
	Control signal Y variable	Open-close 3-point (AC only) Modulating (DC 0...32 V)
	Operating range Y	DC 2...10 V
	Operating range Y variable	Start point DC 0.5...30 V End point DC 2.5...32 V
	Position feedback U	DC 2...10 V
	Position feedback U note	Max. 0.5 mA
	Position feedback U variable	Start point DC 0.5...8 V End point DC 2.5...10 V
	Setting emergency setting position (POP)	Actuator spindle 0...100%, adjustable (POP rotary button)
	Bridging time (PF) variable	1...10 s
	Position accuracy	5% absolute
	Manual override	with push-button
	Nominal stroke	32 mm
	Actuating time motor	150 s / 32 mm
	Actuating time variable	90...150 s / 32 mm
	Actuating time emergency control function	35 s / 32 mm
	Adaption setting range	manual (automatic on first power-up)
	Adaption setting range variable	No action Adaption when switched on Adaption after pushing the gear disengagement button
	Override control	MAX (maximum position) = 100% MIN (minimum position) = 0% ZS (intermediate position, AC only) = 50%
	Override control variable	MAX = (MIN + 33%)...100% MIN = 0%...(MAX - 33%) ZS = MIN...MAX
	Sound power level motor	60 dB(A)
Sound power level emergency control position	60 dB(A)	
Position indication	Mechanically, 5...32 mm stroke	
Safety	Protection class IEC/EN	III Safety extra-low voltage
	Protection class UL	UL Class 2 Supply

Technical data

Safety	Degree of protection IEC/EN	IP54
	Degree of protection NEMA/UL	NEMA 2, UL Enclosure Type 2
	EMC	CE according to 2014/30/EU
	Certification IEC/EN	IEC/EN 60730-1 and IEC/EN 60730-2-14
	Certification UL	cULus according to UL 60730-1A, UL 60730-2-14 and CAN/CSA E60730-1:02
	Mode of operation	Type 1.AA
	Rated impulse voltage supply / control	0.8 kV
	Control pollution degree	3
	Ambient temperature range	0...50°C
	Non-operating temperature	-40...80°C
	Ambient humidity	95% r.h., non-condensing
	Maintenance	Maintenance-free
	Weight	Weight
Terms	Abbreviations	POP = Power off position / emergency setting position CPO = Controlled power off / controlled emergency control function PF = Power fail delay time / bridging time

Safety notes



- This device has been designed for use in stationary heating, ventilation and air conditioning systems and must not be used outside the specified field of application, especially in aircraft or in any other airborne means of transport.
- Only authorised specialists may carry out installation. All applicable legal or institutional installation regulations must be complied during installation.
- The switch for changing the direction of motion and so the closing point may be adjusted only by authorised specialists. The direction of motion is critical, particularly in connection with frost protection circuits.
- The device may only be opened at the manufacturer's site. It does not contain any parts that can be replaced or repaired by the user.
- The device contains electrical and electronic components and must not be disposed of as household refuse. All locally valid regulations and requirements must be observed.

Product features

Mode of operation Conventional operation:
 The actuator is connected with a standard modulating signal of DC 0...10 V and moves to the position defined by the positioning signal at the same time as the integrated capacitors are loaded.
 Interrupting the supply voltage causes the valve to be moved to the selected emergency setting position (POP) by means of stored electrical energy.
 Operation on the MP-Bus:
 The actuator receives its digital positioning signal from the higher level controller via the MP-Bus and drives to the position defined. Connection U serves as communication interface and does not supply an analogue measuring voltage.

Pre-charging time (start up) The capacitor actuators require a pre-charging time. This time is used for charging the capacitors up to a usable voltage level. This ensures that, in the event of an electricity interruption, the actuator can move at any time from its current position into the preset emergency setting position (POP).
 The duration of the pre-charging time depends mainly on following factors:
 – Duration of the electricity interruption
 – PF delay time (bridging time)

Typical pre-charging time

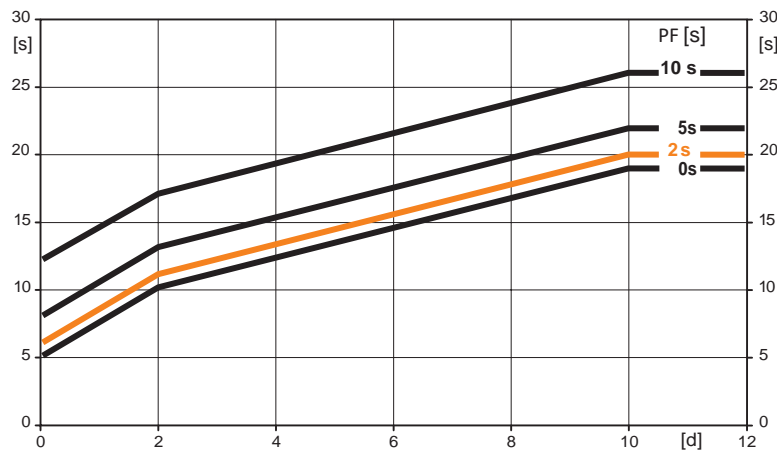

PF [s]	[d]				
	0	1	2	7	≥10
0	5	8	10	15	19
2	6	9	11	16	20
5	8	11	13	18	22
10	12	15	17	22	26

[d] = Electricity interruption in days
 [s] = Pre-charging time in seconds
 PF[s] = Bridging time

Calculation example: Given an electricity interruption of 3 days and a bridging time (PF) set at 5 s, the actuator requires a pre-charging time of 14 s after the electricity has been reconnected (see graphic).

- Delivery condition (capacitors)** The actuator is completely discharged after delivery from the factory, which is why the actuator requires approximately 20 s pre-charging time before initial commissioning in order to bring the capacitors up to the required voltage level.
- Converter for sensors** Connection option for a sensor (passive or active sensor or switching contact). The MP actuator serves as an analogue/digital converter for the transmission of the sensor signal via MP-Bus to the higher level system.
- Parameterisable actuators** The factory settings cover the most common applications. Single parameters can be modified with the Belimo Service Tools MFT-P or ZTH EU.
- Simple direct mounting** Simple direct mounting on the globe valve by means of form-fit hollow clamping jaws. The actuator can be rotated by 360° on the valve neck.
- Manual override** Manual control with push-button possible - temporary. The gear is disengaged and the actuator decoupled for as long as the button is pressed. The stroke can be adjusted by using a hexagon socket screw key (5 mm), which is inserted into the top of the actuator. The stroke spindle extends when the key is rotated clockwise.
- High functional reliability** The actuator is overload protected, requires no limit switches and automatically stops when the end stop is reached.

Product features

Combination valve/actuator	Refer to the valve documentation for suitable valves, their permitted medium temperatures and closing pressures.
Position indication	The stroke is indicated mechanically on the bracket with tabs. The stroke range adjusts itself automatically during operation.
Home position	<p>Factory setting: Actuator spindle is retracted.</p> <p>When valve-actuator combinations are shipped, the direction of motion is set in accordance with the closing point of the valve.</p> <p>The first time the supply voltage is switched on, i.e. at the time of commissioning, the actuator carries out an adaption, which is when the operating range and position feedback adjust themselves to the mechanical setting range.</p> <p>The actuator then moves into the position defined by the positioning signal.</p>
Direction of stroke switch	When actuated, the direction of stroke switch changes the running direction in normal operation. The direction of stroke switch has no influence on the emergency setting position (POP) which has been set.
Adaption and synchronisation	<p>An adaption can be triggered manually by pressing the "Adaption" button or with the PC-Tool. Both mechanical end stops are detected during the adaption (entire setting range).</p> <p>Automatic synchronisation after pressing the gearbox disengagement button is configured. The synchronisation is in the home position (0%).</p> <p>The actuator then moves into the position defined by the positioning signal.</p> <p>A range of settings can be adapted using the PC-Tool (see MFT-P documentation)</p>
Emergency setting position (POP) rotary knob	<p>The rotary knob «Emergency setting position» can be used to adjust the desired emergency setting position (POP) between 0 and 100% in 10% increments. The rotary knob refers to the adapted or programmed height of stroke. In the event of an electricity interruption, the actuator will move into the selected emergency setting position (POP), taking into account the bridging time (PF) of 2 s which was set ex-works.</p> <p>Settings: The rotary knob must be set to the «Tool» position for retroactive settings of the emergency setting position (POP) with the Belimo service tool MFT-P. Once the rotary knob is set back to the range 0...100%, the manually set value will have positioning authority.</p>
Bridging time	<p>Electricity interruptions can be bridged up to a maximum of 10 s.</p> <p>In the event of an electricity interruption, the actuator will remain stationary in accordance with the set bridging time. If the electricity interruption is greater than the set bridging time, then the actuator will move into the selected emergency setting position (POP).</p> <p>The bridging time set ex-works is 2 s. This can be modified on site in operation with the use of the Belimo service tool MFT-P.</p> <p>Settings: The rotary knob must not be set to the «Tool» position!</p> <p>Only the values need to be entered for retroactive adjustments of the bridging time with the Belimo service tool MFT-P.</p>

Accessories

	Description	Type
Gateways	Gateway MP for BACnet MS/TP, AC/DC 24 V	UK24BAC
	Gateway MP to Modbus RTU, AC/DC 24 V	UK24MOD
	Gateway MP to LonWorks, AC/DC 24 V, LonMark certified	UK24LON
	Gateway MP to KNX, AC/DC 24 V, EIBA certified	UK24EIB
Electrical accessories	Description	Type
	Connecting cable 5 m, A+B: RJ12 6/6, To ZTH/ZIP-USB-MP	ZK1-GEN
	Connection cable 5 m, A: RJ11 6/4, B: Free wire end, To ZTH/ZIP-USB-MP	ZK2-GEN
	MP-Bus power supply for MP actuators, AC 230/24V for local power supply	ZN230-24MP
	Connecting board MP bus suitable for wiring boxes EXT-WR-FP..-MP	ZFP2-MP
Auxiliary switch, 2 x SPDT, add-on, grey	S2A-H	
Service Tools	Description	Type
	Service Tool, for MF/MP/Modbus/LonWorks actuators and VAV-Controller	ZTH EU
	Belimo PC-Tool, software for adjustments and diagnostics	MFT-P
	Adapter to Service Tool ZTH	MFT-C

Electrical installation

Notes

- Connection via safety isolating transformer.
- Parallel connection of other actuators possible. Observe the performance data.
- Direction of stroke switch factory setting: Actuator spindle retracted.

Wiring diagrams

AC/DC 24 V, modulating

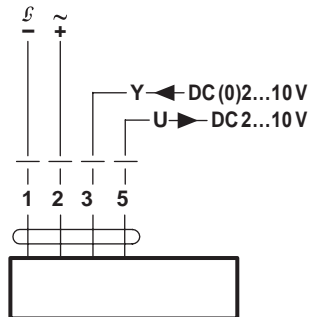

Cable colours:
 1 = black
 2 = red
 3 = white
 5 = orange

Operation on the MP-Bus

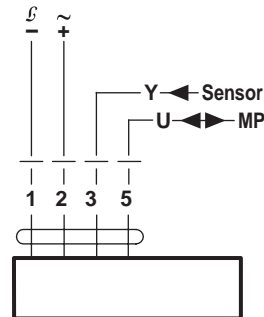

Cable colours:
 1 = black
 2 = red
 3 = white
 5 = orange

Functions

Functions when operated on MP-Bus

Connection on the MP-Bus

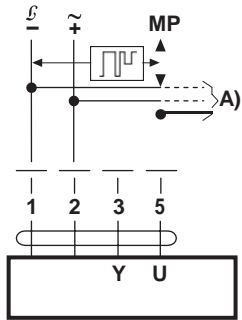

A) more actuators and sensors (max.8)

Network topology

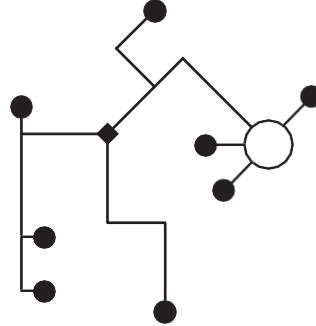

There are no restrictions for the network topology (star, ring, tree or mixed forms are permitted). Supply and communication in one and the same 3-wire cable

- no shielding or twisting necessary
- no terminating resistors required

Connection of external switching contact

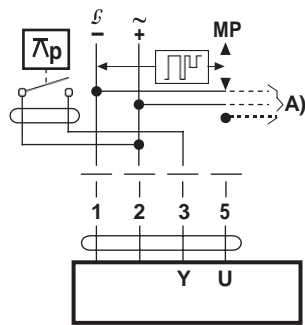
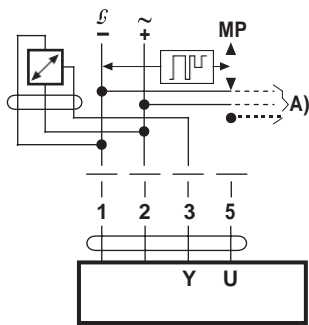

A) more actuators and sensors (max.8)
 • Switching current 16 mA @ 24 V
 • Start point of the operating range must be parameterised on the MP actuator as ≥ 0.5 V

Connection of passive sensors

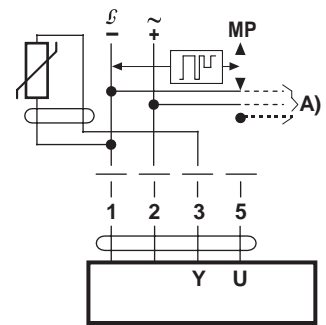

Ni1000	-28...+98°C	850...1600 K ²⁾
PT1000	-35...+155°C	850...1600 K ²⁾
NTC	-10...+160°C ¹⁾	200 K...60 kK ²⁾

A) more actuators and sensors (max.8)
 1) Depending on the type
 2) Resolution 1 Ohm

Functions with basic values (conventional mode)

Override control with AC 24 V with relay contacts

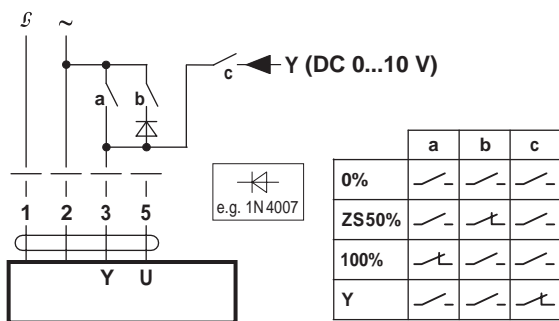

Override control with AC 24 V with rotary switch

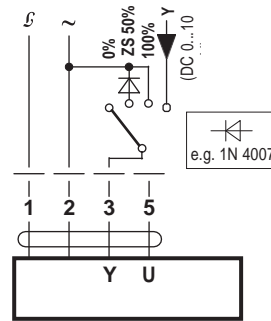

Remote control 0...100% with positioner SG..

Minimum limit with positioner SG..

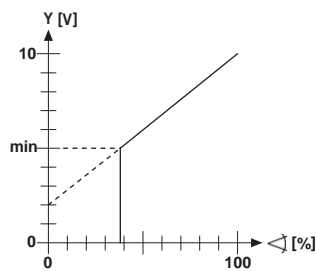
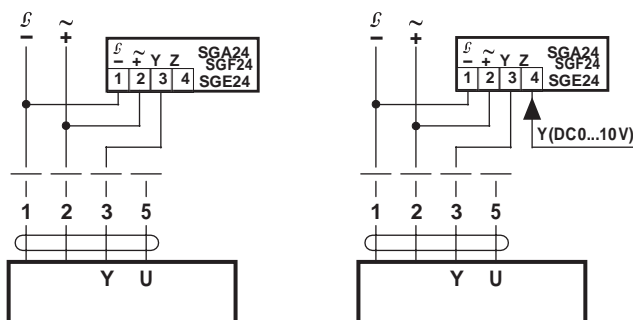

Functions

Follow-up control (position-dependent)

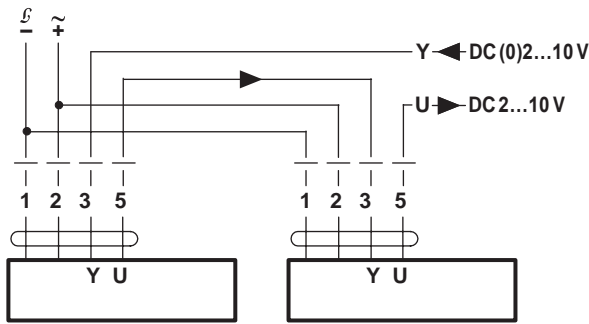

Control with 4...20 mA via external resistor

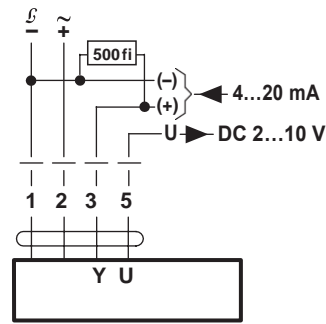

Caution:
The operating range must be set to DC 2...10 V.
The 500 Ω resistor converts the 4...20 mA current signal to a voltage signal DC 2...10 V

Functional check

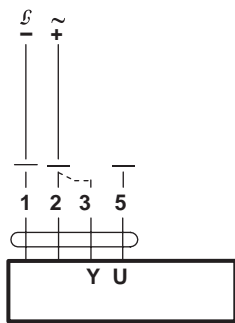

Procedure

1. Apply 24 V to connection 1 and 2
2. Disconnect connection 3:
 - with upwards direction of motion: closing point at top
 - with downwards direction of motion: closing point at bottom
3. Short circuit connections 2 and 3:
 - Actuator runs in the opposite direction

Functions for actuators with specific parameters (Parametrisation with PC-Tool necessary)

Override control and limiting with AC 24 V with relay contacts

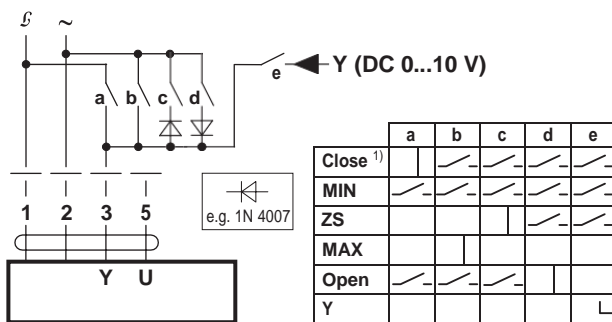

Control open-close

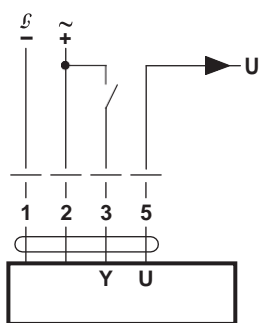

Override control and limiting with AC 24 V with rotary switch

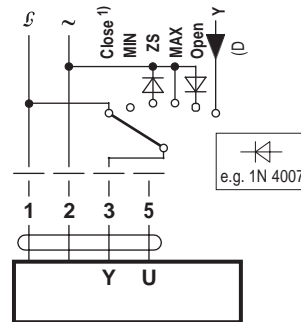

Control 3-point

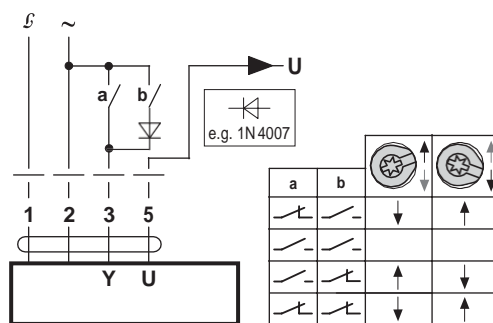

1) Caution: This function is only guaranteed if the start point of the operating range is defined as min. 1.5 V.

Operating controls and indicators

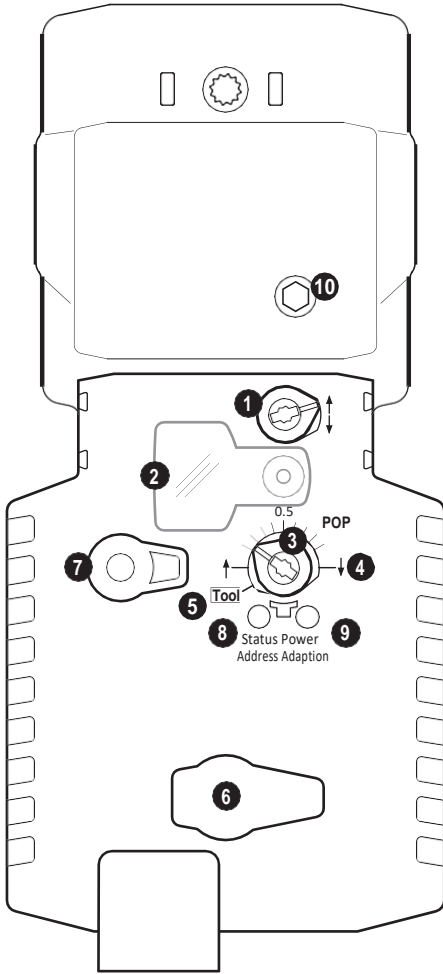

- Direction of stroke switch
Switch over: Direction of stroke changes
- 2 Cover, POP button
- 3 POP button
- 4 Scale for manual adjustment
Position: Adjustment with tool
- 6 Service port
For connecting characterisation and service tools
- Gear disengagement button
Press button: Gear disengaged, motor stops, manual override possible
Release button: Gear engaged, standard mode

LED	Meaning / function
Off	Operation OK
Off	POP function active
On	Pre-charging time SuperCap, Fault SuperCap or wiring error in supply
Off	Not in operation
On	Adaptation process active
Flickering	Communication active

- 8 Push-button (LED yellow)
Press button: Confirmation of addressing
- 9 Push-button (LED green)
Press button: Triggers stroke adaptation, followed by standard mode

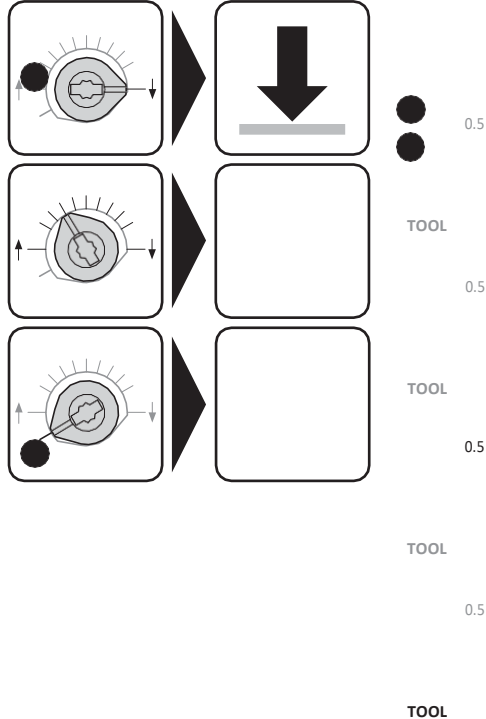
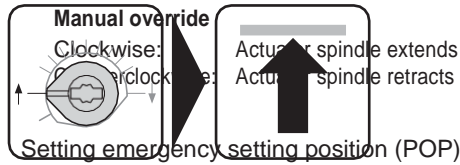

POP %
0 ...100

POP >
PC-Tool

Service



Notes

- The actuator can be parameterised by PC-Tool and ZTH EU via the service socket.

Service Tools connection

ZTH EU connection

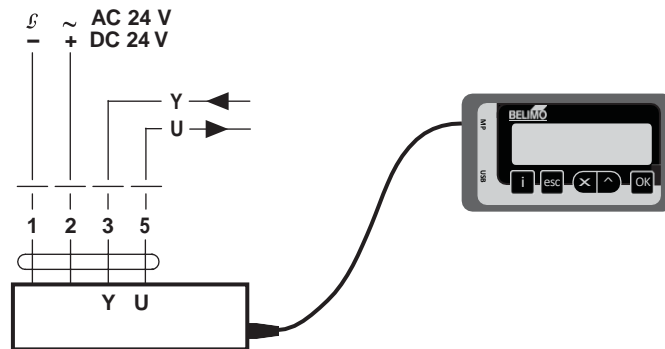

PC-Tool connection

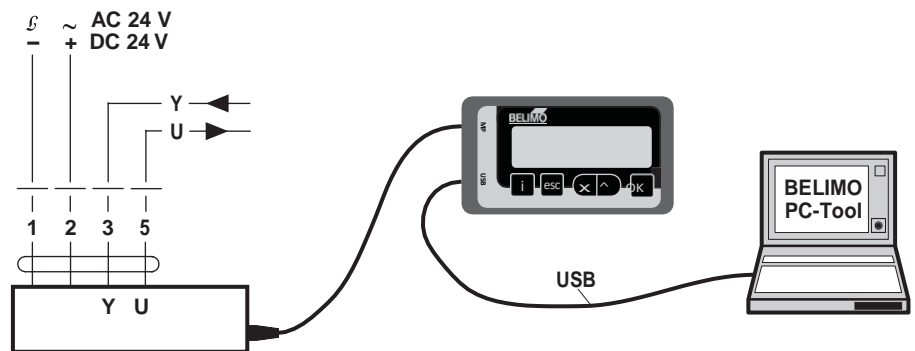

Dimensions [mm]

Dimensional drawings

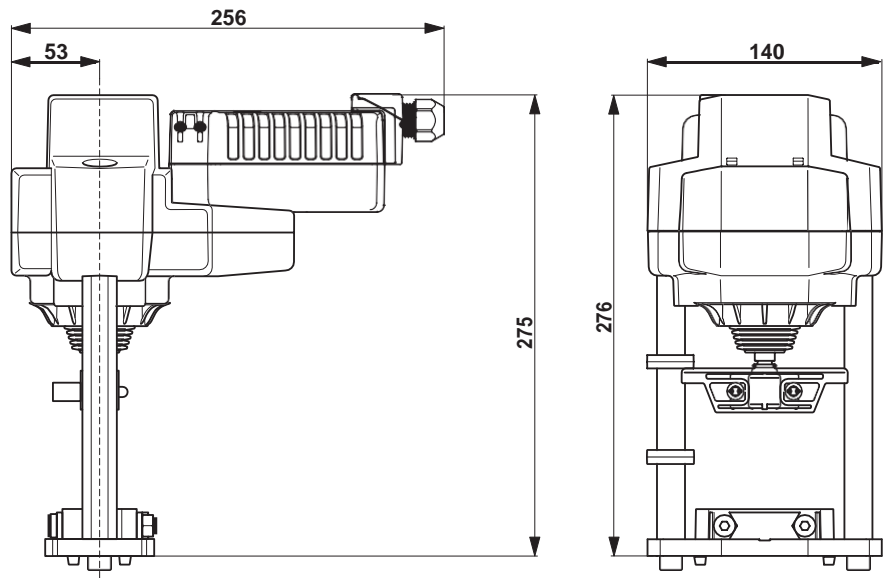

Further documentation

- Overview MP Cooperation Partners
- Tool connections
- Overview Valve-actuator combinations
- Data sheets for globe valves
- Installation instructions for actuators and/or globe valves
- Notes for project planning 2-way and 3-way globe valves
General notes for project planning



C/ Ambocadors, 27 Pol. Ind. El Oliveral, sector 13
46394 Riba-roja de Túria. Valencia. España
Tel. +34 963 309 020 Fax +34 902 875 197
info@zelsio.com www.zelsio.com