

SOLENOID VALVE

Type S4A-DN

Port Size 20-100mm (3/4"-4")

FOR AMMONIA, R12, R22, R502

AND OTHER COMMON REFRIGERANTS

FEATURES

- Standard Coil Housing Meets NEMA 3R and NEMA 4-Rain Tight
- Coil Housing Surpasses NEMA Salt Spray Test
- Plunger-Needle Assembly Same for S4A, S5A, S6N, S6A, S8F
- Molded Class "B" Coil Construction
- Same Coil Fits Most Refrigerating Specialties Solenoid Valves
- Pilot Light Available
- Stainless Steel Needle
- Manual Opening Stem
- Design Pressure (PS): 28 bar (406 PSIG)
- Complies with Pressure Equipment Directive 97/23/EC

Description

This heavy duty solenoid valve is suitable for Ammonia, R-12, R-22, and R-502, other refrigerants, certain oils and other fluids approved for use in refrigeration. The S4A is a pilot operated, semi-steel bodied valve. The valve may be opened by means of the manual opening stem for servicing or in case of electrical power failure.

The Type S4A Solenoid Valve is furnished with FPT Internal NPT (U.S. Standard Taper Pipe Thread), Socket Weld, Weld Neck or ODS (solders over copper tubing of given diameter) connections. The valve may be easily removed from between the flanges for servicing.

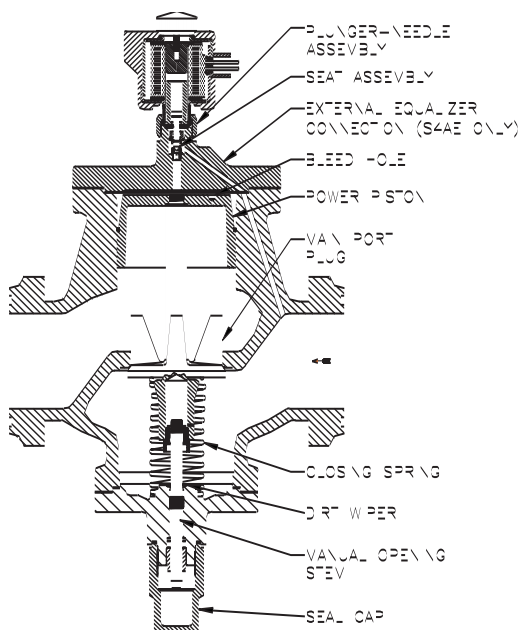

Fig. 1

BULLETIN DN30-94B

Type S4A-DN



January 2007

Installation and Service Information

It is advisable to install a strainer upstream of each valve to prevent entrance of foreign material into the valve and the rest of the system. Refrigerating Specialties strainers are available to close-couple to valve inlets.

Purpose

Type S4A is a spring closing valve, suitable for use in refrigerant liquid, hot gas or suction lines in a temperature range of -50° to 105°C (-60° to 220°F).

Principles of Operation

The **Type S4A** is a pilot operated solenoid. The valve in its closed position, with the solenoid coil de-energized and the plunger needle and main port plug in the seated position, is shown in Figure 1. Electrical energization of the solenoid coil forms a magnetic field, pulling up the plunger which strikes the needle, lifting it off its seat. Upward motion of the needle permits entrance of the fluid from the valve inlet M through Port N and down through the pilot port to the top of the power piston. This forces the piston downward and pushes the main port plug open, thereby permitting flow of the refrigerant through the valve. The closing spring meanwhile is held in a compressed position.

De-energization of the solenoid coil permits the spring-assisted needle to drop back into its seat, stopping the flow through the pilot port. Bleed-off, through the bleed hole in the piston, decreases the pressure above the piston and allows the closing spring to force the main port plug upward into a closed position to stop the flow. The pressure difference across the valve, acting upon the area of the valve seat, plus the force of the closing spring, holds the main port plug in a tightly closed position.

Manual Opening Stem

The manual opening stem on the Type S4A is for the purpose of opening the valve without energizing the solenoid coil. Refer to the applicable exploded view and parts list for location of the stem and other related parts. For access to stem the seal cap on the bottom of the valve must be removed. This must be done with caution as refrigerant may have been trapped inside the seal cap. To open the valve manually, turn the stem counterclockwise as far as it goes. To reset for automatic operation turn the stem clockwise until only the flats on the end of the stem protrude from the packing nut.

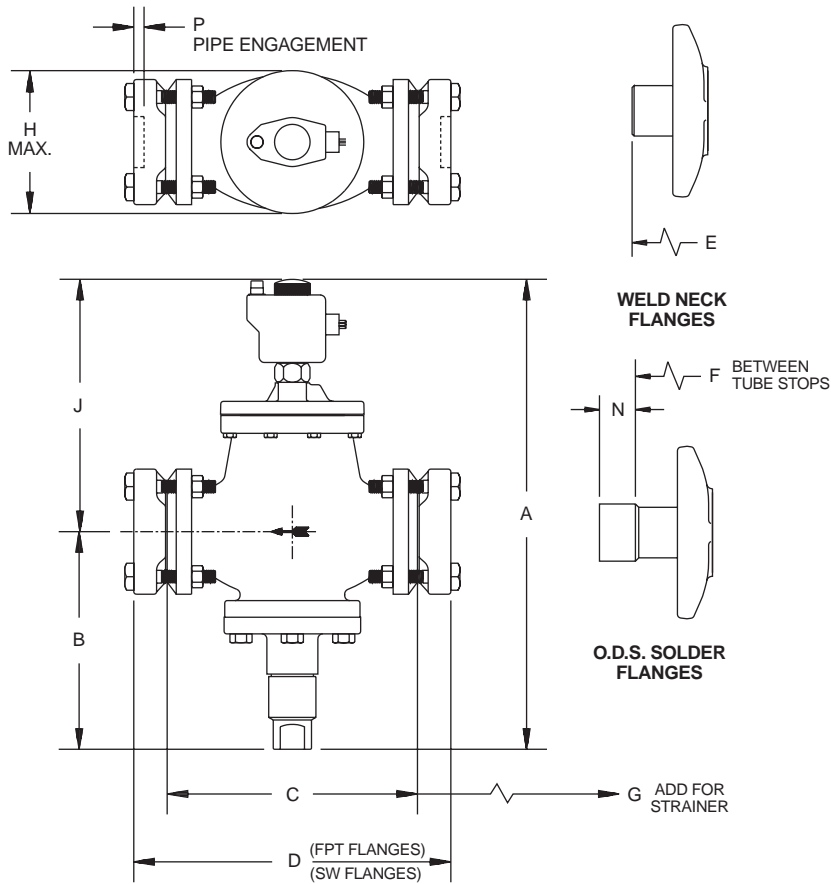

Allow 100mm (4") above valve for removal of coil housing and coil.
 Allow 25m (1.0") below valve to operate manual opening stem.

DIMENSIONAL TABLE

Dimension		PORT SIZE													
		20mm (3/4") & 25mm (1")		32mm (1-1/4")			40 & 50mm (15/8 & 2")			65mm (2-1/2")		75mm (3")		100mm (4")	
A	mm	376	394			442			467		579		645		
	inch	14.8	15.5			17.4			18.4		22.8		25.4		
B	mm	148	162			177			181		273		292		
	inch	5.8	6.3			6.9			7.1		10.7		11.5		
C	mm	164	203			251			251		311		339		
	inch	6.2	8.0			9.9			9.9		12.2		14.1		
D (FPT,SW)	mm	216	256			307			331		389		450		
	inch	8.5	10.1			12.1			13.0		15.3		17.7		
E (WN)	mm inch	261 10.3	1 1/4		1 1/2		1 1/2		2		401 15.8		478 18.8		571 22.5
			300 11.8	304 12.0	364 14.3	371 14.6									
F (ODS)	mm inch	239 9.4	1 3/8	1 5/8	2 1/8	1 5/8	2 1/8	2 5/8	2 5/8	3 1/8	3 1/8	3 5/8	303 19.8		
			269 10.6	279 11.0	304 12.0	358 14.1	338 13.3	358 14.1	348 13.7	389 15.3	414 16.3	432 17.0			
G	mm inch	98 3.9	178 7.0			251 9.9			314 12.4		314 12.4		363 14.3		
			117 4.6			140 5.5			159 6.2		176 7.0		222 8.8		
J	mm inch	224 8.8	231 9.1			284 11.2			300 11.8		312 12.3		353 13.9		
			1 3/8	1 5/8	2 1/8	1 5/8	2 1/8	2 5/8	2 5/8	3 1/8	3 1/8	3 5/8	4 1/8		
N (ODS)	mm inch	25 1.0	25 1.0	28 1.1	33 1.3	28 1.1	33 1.3	38 1.5	38 1.5	43 1.7	43 1.7	48 1.9	55 2.2		
			1-1/4		1-1/2		1-1/2		2		25		29		32
P (SW)	mm inch	13 0.5	15 0.6		15 0.6		15 0.6		15 0.6		25 1.0		29 1.1		32 1.3

S4A-DN	3/4" TO 4"
PRESSURE BEARING COMPONENTS	
COMPONENT DESCRIPTION	MATERIAL
BODY, 1-1/4 TO 4"	DUCTILE IRON GGG 40.3
BODY, 3/4 & 1" S4A DN	ASTM A-126 CLASS B
COVER,BOTM A4A/S4A 3/4 TO 1-1/4	1-7/8 RD 1215 STEEL
COVER,BOTM A4A/S4A 1-5/8 TO 4"	DUCTILE IRON GGG 40.3
ADAPTER ASM,S4A DN 1-1/4	DUCTILE IRON GGG 40.3
SLEEVE, SOLENOID TUBE	AISI 1117 CRS BARSTOCK

**For replacement parts and prices, consult
PARTS KITS LIST PRICE SCHEDULE INDUSTRIAL
AND FLO-CON (PK)**

Item	Description
1	Knob
2	O-Ring
3	Coil Asm
7	Tube Assembly
8	Gasket
9	Plunge Needle Assembly
10	Seat Assembly
11	Adapter Assembly
12	Gasket
13	Piston
14	Body
15	Bolt
16	Plug Stem Asm
17	Spring, Comp
18	Washer
19	Wiper, Dirt
20	O-Ring
21	Cover, Bottom
22	Washer, Flat
23	Packing, Stem
24	Nut, Packing
25	Gasket
26	Bolt
27	Seal Cap

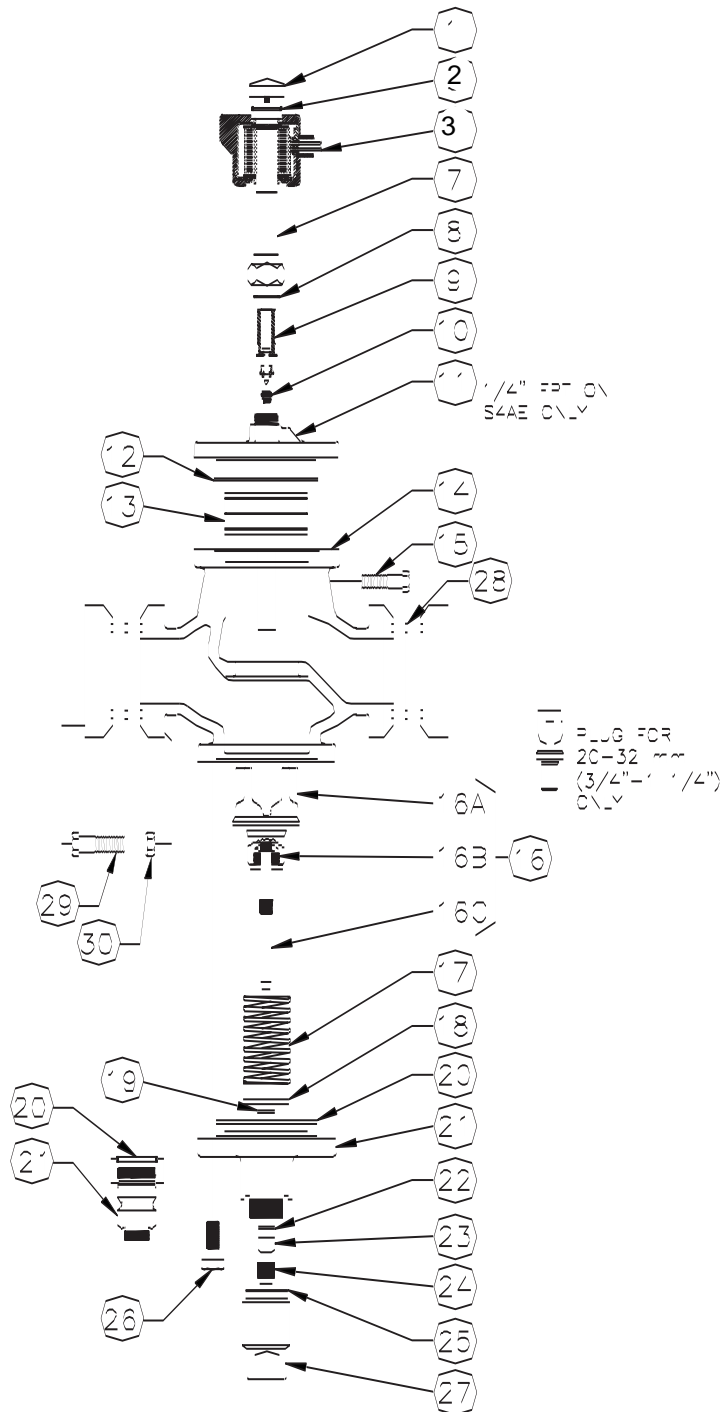

Installation

Protect inside of valve from dirt, chips and moisture during installation. Mount only in horizontal pipe line with solenoid coil at the top; this valve will work properly only in this position. In a liquid line the Solenoid Valve should be near the expansion valve inlet. It is advisable to install the S4A close coupled companion strainer ahead of the valve for protection against dirt and chips.

The S4A solenoid valve must be installed with the arrow on the valve body in the direction of flow through the valve. If the valve is backwards, the flow will not be stopped when the valve is electrically de-energized. Like all Solenoid Valves, the S4A can stop flow only in the direction from normal inlet to normal outlet (as shown by the arrow on the body). If reversal of pressure occurs in the system so the outlet pressure exceeds the inlet pressure the piston will be blown away from its seat and reverse flow will occur. If a system has this type of pressure reversal (as encountered during hot gas defrost with liquid recirculation systems), a check valve such as Refrigerating Specialties Division Type CK4A in series with the solenoid valve will prevent flow reversal. (CK4A must be installed downstream to avoid trapping liquid.)

Electrical

The Refrigerating Specialties Division molded water resistant Class "B" solenoid coil is designed for long life and powerful opening force. The standard coil housing meets NEMA 3R and 4 requirements. This sealed construction can withstand direct contact with moisture and ice. The coil housing far exceeds the requirements of NEMA Standard ICS, 1-110.57 salt spray test for rust resistance.

By definition, Class "B" coil construction will permit coil temperatures, as measured by resistance method, as high as 130°C (266°F). Final coil temperatures are a function of both fluid and ambient temperatures. The higher fluid temperatures require lower ambient temperatures so the maximum coil temperature is not exceeded. Conversely, low fluid temperatures permit higher ambient temperatures.

The molded Class "B" coil is available from stock with most standard voltages. However, coils are available for other voltages and frequencies, as well as for direct current. Coils are also available as transformer type with a 6 volt secondary winding for use with the Refrigerating Specialties Division Pilot Light Assembly (see current copy of Bulletin 60-10, "Pilot Light Assembly and Solenoid Transformer Coil").

The solenoid coil must be connected to electrical lines with volts and Hertz same as stamped on coil. The supply circuits must be properly sized to give adequate voltage at the coil leads even when other electrical equipment is operating. The coil is designed to operate with line voltage from 85% to 110% of rated coil voltage. Operating with a line voltage above or below these limits may result in coil burnout. Also, operating with line voltage below the limit will definitely result in lowering the valve opening pressure differential. Power consumption during normal operation will be 33 watts or less.

Inrush and running current is listed below:

Standard Volts/Hertz	Inrush Current (Amps)	Running Current (Amps)	Fuse Size (Amps)
120/60 (Blue leads)	1.18	0.46	1
208/60 (Blue & Red leads)	0.63	0.25	1
240/60 (Red leads)	0.60	0.23	1
440/60 (Yellow & Red leads)	0.39	0.13	1
115/50 (Yellow & Blue leads)	1.22	0.21	1
230/50 (Yellow leads)	0.65	0.261	
Other	(Contact Factory)		

On transformer coil the 6 volt leads are always black.

Service Pointers

The S4A Solenoid Valve and Strainer are easily removable for cleaning or repairing. To remove valve and strainer, first manually open the valve and pump out the refrigerant in the section of the line sealed off. Then unscrew the flange bolts and spread the flanges slightly apart.

1. Failure to Open: (a) Coil is of incorrectly high voltage. See "Electrical." Check voltage printed on the coil. (b) Line voltage is abnormally low. See "Electrical." Check line voltage at coil leads with a voltmeter. (c) Failure to electrically energize. Check control circuit. (d) Pressure difference across valve is too high. The S4A will open against a maximum pressure difference across the valve of 21 bar (300 psig). (e) Solenoid Coil is burned out. See "Electrical," and replace with proper coil. (f) Plunger/Needle Assembly is sticking. To disassemble the S4A for inspection of internal parts (after pumping out the system as required): disconnect power source to #4 Solenoid Coil, remove #7 Tube Assembly, lift out #9 Plunger Assembly,

then remove #11 Adapter Assembly. Remove every trace of dirt from the piston and cylinder using fine emery cloth to remove burrs if necessary. Thoroughly clean all parts and reassemble using a light film of refrigeration oil on the Piston.

2. Failure to Close: (a) Electrical control circuit is not opening properly. Check wiring and controls. (b) There are chips or dirt on the Pilot Seat or the Main Valve Seat, preventing proper seating. Disassemble and clean Valve as outlined in (1f) above. (c) Main Valve Seat, Pilot Seat, or Valve Needle may be worn or damaged and therefore leaking. Disassemble and clean Valve as outlined in (1f) above. If any of these parts need replacing, it is advisable to replace using the proper replacement kit. (d) #13 Piston is sticking. See (1f) above. (e) #16C Manual Opening Stem is turned all or partly out holding #16A Modulating Plug Assembly open and permitting flow through the valve. (f) #5 Coil Housing Screw (made of non-magnetic stainless steel) has been replaced with a screw made of magnetic material and residual magnetism is holding #9 Plunger Needle Assembly in the open position. Consequently, the Main Valve is not closing. Replace with screw of correct material.

3. Leakage Through Valve: See (2) above.

4. Overheating: The Solenoid Coil is designed to operate hot and is constructed of high temperature materials accordingly. Unless troubled with actual Coil burnouts, high coil temperature should be ignored. Persistent burnouts indicate improper line or coil voltage. See (1e) above.

Warranty

All Refrigerating Specialties Products are warranted against defect in workmanship and materials for a period of one year from date of shipment from factory. This warranty is in force only when products are properly installed, field assembled, maintained and operated in use and service as specifically stated in Refrigerating Specialties Catalogs or Bulletins for normal refrigeration applications, unless otherwise approved in writing by Refrigerating Specialties Division. Defective products, or parts thereof, returned to the factory with transportation charges prepaid and found to be defective by factory inspection will be replaced or repaired at Refrigerating Specialties option, free of charge, F.O.B. factory. Warranty does not cover products which have been altered or repaired in the field, damaged in transit, or have suffered accidents, misuse, or abuse. Products disabled by dirt or other foreign substances will not be considered defective.

THE EXPRESS WARRANTY SET FORTH ABOVE CONSTITUTES THE ONLY WARRANTY APPLICABLE TO REFRIGERATING SPECIALTIES PRODUCTS, AND IS IN LIEU OF ALL OTHER WARRANTIES. EXPRESS OR IMPLIED, WRITTEN OR ORAL, INCLUDING ANY WARRANTY OF MERCHANTABILITY, OR FITNESS FOR A PARTICULAR PURPOSE. No employee, agent, dealer or other person is authorized to give any warranties on behalf of Refrigerating Specialties, nor to assume, for Refrigerating Specialties, any other liability in connection with any of its products.

Safe Operation (see also Bulletin RSB)

People doing any work on a refrigeration system must be qualified and completely familiar with the system and the Refrigerating Specialties Division valves involved, or all other precautions will be meaningless. This includes reading and understanding pertinent Refrigerating Specialties Division Product Bulletins, and Safety Bulletin RSBCV prior to installation or servicing work.

Where cold refrigerant liquid lines are used, it is necessary that certain precautions be taken to avoid damage which could result from liquid expansion. Temperature increase in a piping section full of solid liquid will cause high pressure due to the expanding liquid which can possibly rupture a gasket, pipe or valve. All hand valves isolating such sections should be marked, warning against accidental closing, and must not be closed until the liquid is removed. Check valves must never be installed upstream of solenoid valves, or regulators with electric shut-off, nor should hand valves upstream of solenoid valves or downstream of check valves be closed until the liquid has been removed. It is advisable to properly install relief devices in any section where liquid expansion could take place.

Avoid all piping or control arrangements which might produce thermal or pressure shock.

For the protection of people and products, all refrigerant must be removed from the section to be worked on before a valve, strainer, or other device is opened or removed.

Flanges with ODS connections are not suitable for ammonia service.