

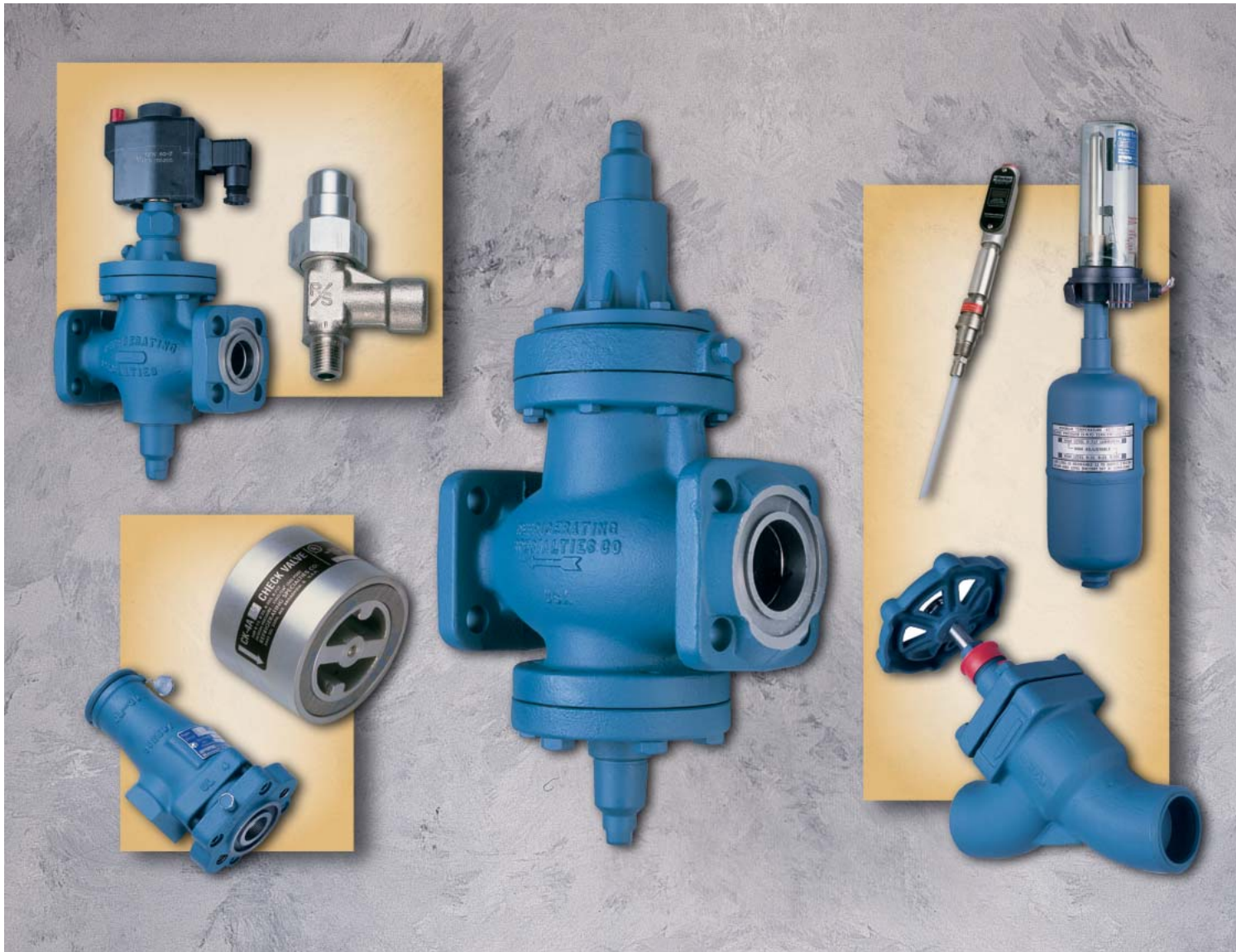

Industrial Refrigeration Control Valves

Catalog CC-11c/US



Refrigerating Specialties Division

Based on over 88 years of experience in industrial refrigeration, the Refrigerating Specialties Division of Parker Hannifin Corporation has grown from an industry pioneer to a leading worldwide supplier of industrial refrigeration control valves. Our reputation for excellence in design engineering, manufacturing capabilities and quality performance has positioned us as a dominant force in the industrial refrigeration marketplace.

To contact us:

Phone:

(708) 681-6300 or 1-800-506-4261

Fax:

(708) 681-6306 or 1-800-424-7109

e-mail:

RSD_info@parker.com

Visit our web site:

www.parker.com/refspec

WARNING

FAILURE OR IMPROPER SELECTION OR IMPROPER USE OF THE PRODUCTS AND/OR SYSTEMS DESCRIBED HEREIN OR RELATED ITEMS CAN CAUSE DEATH, PERSONAL INJURY AND PROPERTY DAMAGE.

This document and other information from Parker Hannifin Corporation, its subsidiaries and authorized distributors provide product and/or system options for further investigation by users having expertise. It is important that you analyze all aspects of your application, including consequences of any failure and review the information concerning the product or system in the current product catalog. Due to the variety of operating conditions and applications for these products or systems, the user, through its own analysis and testing, is solely responsible for making the final selection of the products and systems and assuring that all performance, safety and warning requirements of the application are met.

The products described herein, including without limitation, product features, specifications, designs, availability and pricing, are subject to change by Parker Hannifin Corporation and its related companies at any time without notice.

Offer of Sale

The items described in this document are hereby offered for sale by Parker Hannifin Corporation, its subsidiaries or its authorized distributors. This offer and its acceptance are governed by the provisions stated in the full "Offer of Sale" at the end of this document.

Contents

Pressure Regulators	
A4A/A4W	3
Applications	5
Modules	6
Ordering	8
Accessories	9
Suction Capacities	10
Liquid, Oil Capacities	12
Hot Gas Bypass	12
Pilots	14
A2A/A2B/A2CK	15
Solenoid Valves	16
Ordering	17
Capacities	18
Gas Powered Valves	20
Ordering	21
Suction Capacities	22
Gravity Flooded Capacities	23
Safety Relief Valves	
Type H	24
Type SR/SRH	25
Hot Gas Defrost Valves	26
Constant Flow Regulator (CFR)	28
Check Valves	29
Type CK4	30
Type CK1, CK3	31
Stop/Check Valves	32
Rapid Purger	33
Flow Regulators	34
Liquid Level Float Switches	35
Sight Glass	35
Automatic Liquid Drainer	36
PLLC	37
DepthTracker Probes	37
Flanges	38
Hand Valves	40
Stop/Strainers	42
Strainers	43
Gauge Valves	44
Gauges	45
Refrigerant Pumps	
Type HRP	46
Type GP	47
Liquid Drain Ball Valves	48
Spray Paint	48
Valve Classifications	49
General Information	50
Offer of Sale	51





Flanged Body Style
 20-100mm (¾" - 4") Ports



Weld End Body Style
 125-200mm (5" - 8") Ports

Description

The A4 family of regulators includes valves that control inlet, outlet or differential pressure. Each regulator is available with an assortment of additional variations which enable one regulator to perform several functions. The most common arrangements are shown on the following pages.

These compact, heavy-duty, pilot-operated regulators are suitable for use with Ammonia, R-22, R-134a, R-404A, R-507 and other common refrigerants and fluids approved for use in refrigeration systems. Capacity charts within this industrial catalog cover Ammonia and R-22 exclusively. Please contact the factory for information concerning capacities for other refrigerants.

A4 regulators with variations are normally ordered factory assembled and tested. However, the A4Z regulators and the Adaptomode® modules are available separately for stock or field conversions.

The A4R regulators are available for remote pilot operation. The pilot regulator (A2B) and pilot solenoid must be ordered separately.

Materials

- Body:
 - 20-100mm Gray Iron (ASTM A126 Class B)
 - 125-200mm Cast Steel (A-352 GR, LCB)
- Seat Lapped Metal to Metal
 except A4AK 20-32mm (¾" to 1¼") PTFE
- Pilot Seat Chrome Plated Steel
- Diaphragm Stainless Steel, Preformed

Specifications

- Maximum Fluid Temperature 105°C (220°F)
- Minimum Fluid Temperature:
 - 20-32mm (¾" to 1¼") -45°C (-50°F)
 - 40-200mm (1½" to 8") -50°C (-60°F)
- Design Pressure (MRP) 27.6 bar (400 psig)

Common Variations



A4A
Inlet Pressure Regulator



A4AO
Outlet Pressure Regulator

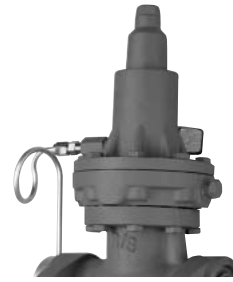

A4AL
Differential Pressure Regulator



A4AZ
Inlet Pressure Regulator
with Modudapter®

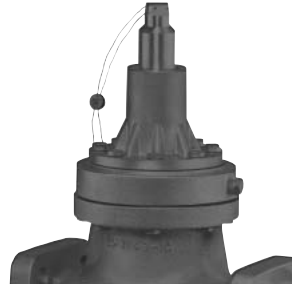

A4AK
Reseating Relief
Regulator



A4AP
Pneumatically Compensated
Regulator



A4AM
Electrically Compensated
Inlet Pressure Regulator



A4AB
Inlet Pressure Regulator with
Wide Opening Feature



A4AS
Inlet Pressure Regulator with
Electric Shut-Off Feature



A4AOT
Temperature Operated
Outlet Regulator

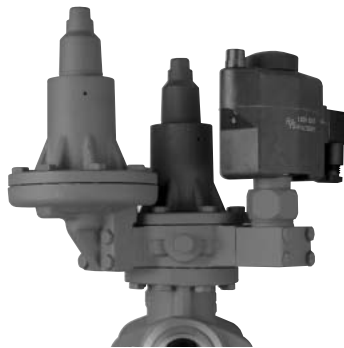

A4AD
Dual Inlet Pressure
Regulator



A4AJS
Electronic Pilot Operated Regulator
with Electric Shut-Off Feature

Application Guide

There are many possible combinations of A4 regulator variations. The electric shut-off (S), electric wide-opening (B) and dual pressure (D) variations are often combined with each other. Or they may be used in combination with the compensated (M, P, 3P and T), outlet pressure (O) or differential pressure (L) regulators. Remote configurations of most variations are available using the A4R regulator separate from pilot controls.

The A4A Series flanged body regulators are available with 20mm to 100mm (3/4" to 4") ports.
 The A4W Series weld end body regulators are available with 125mm to 200mm (5" to 8") ports.

Variation	Type Suffix	Type	Function	Operation	Typical Applications
Basic regulator	—	A4A A4W	Control inlet pressure	Operates at present inlet pressure. Can be field adjusted. Opens on rising inlet pressure.	1. Evaporator pressure control 2. Condenser pressure control 3. Any inlet pressure control
Electric shut-off	S	A4AS A4WS	Control inlet pressure or shut off regulator	Regulates when electrically energized; closed when not energized.	1. Open for temperature control 2. Closed for defrosting
Electric wide opening	B	A4AB A4WB	Control inlet pressure or wide open regulator	Regulates when not electrically energized; wide open when energized.	1. Wide open for maximum cooling 2. Regulating for defrost 3. Regulating for temperature control.
Dual Pressure	D	A4AD A4WD	Dual pressure control	Regulates at lower pressure when electrically energized; at higher pressure when not energized.	1. Higher pressure for defrost 2. Higher pressure for temperature control. 3. Internal pressure relief.
Reseating relief	K	A4AK	Reseating relief regulator	Open wide above set point. Repeatedly reseats after operation.	1. Defrost relief 2. Non-atmospheric relief 3. High to low relief
Outlet pressure regulator	O	A4AO A4WOE	Control outlet pressure	Regulates at preset outlet pressure. Can be field adjusted. Opens on a drop in outlet pressure.	1. Crankcase pressure regulation 2. Hot gas bypass; booster loading 3. Receiver pressure control
Differential pressure regulator	L	A4AL	Control pressure difference across regulator	Regulates pressure difference at or below a pre-set amount.	1. Liquid pump relief regulator 2. Reduce liquid or vapor line pressure
Electrically compensated	M	A4AM A4WM	Motor changes pressure set-point	Potentiometer or solid state type thermostat readjusts set-point to match evaporator temperature to a varying load.	1. Precise control of process cooling 2. Liquid chillers 3. For load change compensation
Pneumatically compensated	P, 3P	A4AP A4WP A4A3P A4W3P	Air pressure changes set-point (1:1 ratio); A4A3P for 3:1 ratio	Pneumatic thermostat readjusts set-point to match evaporator temperature to a varying load.	1. Precise control of process cooling 2. Liquid chillers 3. For load change compensation
Temperature operated	T	A4AT A4WT A4AOT A4WOET	Temperature bulb controls regulator opening	Increase in temperature opens regulator; decrease in temperature closes regulator. Also reverse acting with "O" variation.	1. Process cooling systems 2. Liquid chillers 3. Systems with load change 4. Heat reclaim
Electronic pilot operated	J	A4AJ	Electronic signal controls regulator opening	Pilot position is proportional to electronic signal.	1. Precise control 2. Liquid chiller 3. System with load change
Externally equalized	E	A4AE A4AOE etc.	Control at external pressure sensed remote from valve	Same as standard regulator except controlled pressure is sensed away from regulator.	1. Low Pressure drop (A4AE) 2. Hot gas bypass (A4AOE)
Main regulator for remote pilot	R	A4AR A4WR	Main regulator is controlled by separate pilots	Main regulator modulates, closes or opens in response to remote pilots.	1. Simple inventory of regulator and pilots 2. Convenient placement of pilots 3. Unusual pilots or circuits
Basic regulator assembly	Z	A4AZ	Complete regulator assembly to which modules can be added.	Can be built into most of the A4A variation regulators. Has a Modudapter® and two Moduplates®.	Versatile unit for inventory along with Adaptomode Modules sold separately.

***These are the most common variations of the Type A4 regulator.
 For other combinations, please consult factory.***

A2D Modular Pressure Pilot



Adds dual (D) variation when combined with Modular Solenoid Pilot (page 7). Provides a second higher control pressure.

Furnished with bolts and O-rings. Mounts to Modudapter®.

To order: Specify Type and Range.
Use A2D2 with 20-50mm (¾" - 2") ports.
Use A2D with 65-200mm ports (2½" - 8") ports.

Range A (standard): 0-10.3 bar
(0 to 150 PSIG)
Range D: 5.2 to 19.3 bar (75 to 280 PSIG)

Outlet Regulator Kit (OR)



An auxiliary adapter which converts A4A inlet regulators to outlet regulators with OE variation.

Furnished with all internal parts, bolts and gaskets.

To order: Specify Type.
Type OR50 for 20-50mm (¾" - 2") ports.
Type OR200 for 65-200mm (2½" - 8") ports.

Motor Bonnet Kit (MB)



Converts to electric compensation (M) variation any A4 Series regulator. Standard in A range. Combine with VC vacuum cartridge for V range.

Furnished with bonnet, all internal parts, cam, bolts, gaskets, motor and transformer with 24 Volt secondary to operate motor.

Same for all port sizes.

To order: Specify Type MB, Volts, Frequency, 135ohm or 4-20mA signal and Honeywell or Penn motor.

Temperature Bonnet Kit (TB)



Converts to temperature operated (T and OT) variation any A4 regulator.

Low range: -30° to 30°C
(-20° to 80°F)
High range: 20° to 60°C
(60° to 140°F)

Furnished as complete bonnet assembly including 15.9 x 133.4mm (5/8" x 3¼") bulb, 6m (20 ft.) capillary, bolts, gaskets and O-rings. Consult factory for 33' capillary. Kit for A4OT (¾" to 4" only) includes tubing assembly for downstream connection.

To order: Specify Type and Range.
Type TB50 for 20-50mm (¾" - 2") A4AT.
Type TB200 for 65-200mm (2½" to 8") A4AT, A4WT.
Type TBO200 for 20-200mm (¾" - 8") A4AOT, A4WOT.

Modudapter® (MD, SMD)



The special adapter to which the modular solenoid pilot, modular pressure pilot and Moduplate are bolted.

The **Series Modudapter (SMD)** is used with special regulators such as A4ADS, A4ABDS, etc. and with all A4W regulators. Furnished with bolts and gaskets. (Standard part of regulators with S, B, D and Z variations)

To order: Specify Type.
Type MD25 for 20-25mm (¾" - 1") ports
Type MD32 for 32mm (1¼") port
Type MD50 for 40-50mm (1½" to 2") ports
Type MD65 for 65mm (2½") port
Type MD75 for 75mm (3") port
Type MD100 for 100mm (4") port
Type SMD65 for 20-65mm (¾" - 2½") ports and 125-200mm (5" - 8") ports
Type SMD100 for 75-100mm (3" - 4") ports

Moduplate® (MP)



Provides blankoff or cross-over of pilot circuit on Type A4S or Type A4B.

Attaches to Modudapter. Same for all regulator sizes.

Furnished with bolts and three O-rings.

To order: Specify Type MP.

Vacuum Cartridge (VC)



A pilot seat with vacuum range cartridge. Will change A range A4, A2B or A2D to vacuum range: 500mm Hg to 8.3 bar (20 in Hg to 120 PSIG).

Furnished with diaphragm and necessary gasket. Same for all regulator sizes.

To order: Specify Type VC.

Pressure Bonnet Kit (PK)



Converts any A4, A4O or A2 Series regulator to 1:1 Pressure Compensation (P) variation. Standard in A range. Use with Type VC vacuum cartridge for V range.

Also available 3:1 pressure compensation (3P) variation.

Furnished with ¼" FPT bonnet connection for air or refrigerant pressure, bolts and gaskets. 3:1 kit includes above plus auxiliary adapter.

Same for all port sizes.

To order: Specify Type.
Type PK1 for 1:1 ratio.
Type PK3 for 3:1 ratio

S6A Modular Solenoid Pilot (Standard)



Adds electric shut-off (S) or electric wide opening (B) and is used with Modular Pressure Pilot A2D/A2D2 for dual (D) variations. Uses Class "B" coil.

Furnished with bolts and O-rings. Mounts to Modudapter®. Same for all regulator sizes.

Specify Type S6A, Coil Style (leaded or DIN connector), Volts and Frequency, and pilot light, if required.

S6B Compact Modular Solenoid Pilot (Optional)



The S6B is an optional pilot solenoid which can be mounted on the A4 Modudapter, adding a variety of functions to a basic regulator. Due to the "spring assisted" construction of the valve's plunger assembly, the regulator and the pilot S6B can be mounted on its side as opposed to the S6A, which must be mounted in a vertical position for the pilot solenoid to positively close when de-energized.

Adds electric shut-off (S) or electric wide opening (B) and is used with Modular Pressure Pilot A2D/A2D2 for dual (D) variations. Uses Class "H" coil.

Furnished with bolts and O-rings. Mounts to Modudapter®. Same for all regulator sizes.

Specify Type S6B, Coil Style, Volts and Frequency.

Voltages

Coils are available from stock with most standard voltages (see table below). Non-standard voltages (shown in the shaded area of table) are available as special order. Coils are also available with 6V secondary voltage for use with remote pilot lights PLT-1 and PLT-2. The PLT-5 is a remote, line voltage pilot light, typically used in conjunction with an S6B pilot solenoid. Consult factory for other voltages.

Available Voltages for Coils and Remote Pilot Lights	Module	Class	120/60	120/6/60	208/60	208/6/60	240/60	240/6/60	115/50	230/50	240/50	24/60	24/50	48/50	24VDC	48VDC
Encapsulated w/Leads	S6A	B	●	●	●	●	●	●		●		●	●	●	●	
Encapsulated w/Leads & Integral Pilot Light	S6A	B	●		●		●									
Encapsulated w/DIN Connector	S6A	B	●				●		●	●	●				●	●
Encapsulated w/DIN & Integral Pilot Light	S6A	B	●				●		●	●	●					
Compact Operator w/Leads	S6B	H	●		●		●		●	●	●					
Compact Operator w/DIN Connector	S6B	H	●		●		●		●	●	●					
Remote Pilot Light PLT-1 (NEMA 1)				●		●		●								
Remote Pilot Light PLT-2 (NEMA 4)				●		●		●								
Remote Pilot Light PLT-5 (NEMA 4)			●		●		●									

NOTES:

Remote pilot lights cannot be used with explosion proof or unleaded coils.

An explosion proof pilot solenoid is available for the R/S A4 line of regulators. Contact factory for voltages and valve configurations.

Ordering Guide for A4A/A4W Pressure Regulators

Port Size		Reduced Capacity Plug	Flow Coefficient		Connections Available				Net Weight			
									Less Strainer		w/Strainer	
mm	Inch		Kv	Cv	FPT	SW, WN	ODS	DIN WN	kg	lb	kg	lb
20	3/4	50% 17%	6.8 3.8 1.1	8.0 4.4 1.3	¾", 1", 1½"	¾", 1", 1½"	7/8", 1½", 1¾"	20, 25, 32	9.5	21	12.3	27
25	1"	①	9.3	11	¾", 1", 1½"	¾", 1", 1½"	7/8", 1½", 1¾"	20, 25, 32	10.0	22	12.7	28
32	1¼"	35%	15 5.7	18 6.6	1¼", 1½"	1¼", 1½"	1¾", 1¾", 2½"	32, 40	13.2	29	19.1	42
40	1½"	35%	27 12	32 14	1½", 2"	1½", 2"	1¾", 2½", 2¾"	40, 50	28	62	34	75
50	2"	②	46	53	1½", 2"	1½", 2"	1¾", 2½", 2¾"	40, 50	28	62	34	75
65	2½"	35%	64 22	75 26	—	2½", 3"	2¾", 3½"	65, 75	28	62	34	75
75	3"	35%	86 30	100 35	—	3"	3½", 3¾"	75	50	110	75	163
100	4"	35%	130 38	150 44	—	4"	4½"	100	74	162	116	256
125	5"	35%	170	200	—	5" Weld end only	N.A.	N.A.	54	120	99	220
150	6"		310	360	—	6" Weld end only	N.A.	N.A.	98	215	177	390
200	8"		470	550	—	8" Weld end only	N.A.	N.A.	159	350	295	650

Standard connection styles: FPT for 20-50mm (¾" - 2"); SW for 65-100mm (2½" - 4").
 Standard size and style will be furnished unless specified otherwise.

① All 20mm (¾") plugs also fit in 25mm (1") valves.

② All 40mm (1½") plugs also fit in 50mm (2") valves.

Regulator Variations

Added Variation	Add	For Type	Additional Information	Bulletin Number
Electric Shut-Off	S	A4AS/A4WS	Specify Volts, Frequency	23-06
Electric Wide Opening	B	A4AB/A4WB	Specify Volts, Frequency	23-06
Dual Pressure Regulator	D	A4AD/A4WD	Specify Volts, Frequency and both Pressure Ranges	23-06
Reseating Relief Regulator	K	A4AK	Specify Setting. Factory set and tagged. Standard 4.9 bar (70 psi)	23-05
Outlet Pressure Regulator	O	A4AO/A4WOE	Specify E Variation (A4AOE) if for external equalizer	23-07
Differential Pressure Regulator	L	A4AL	Determine Range from pressure difference required	23-10
Electrically Compensated	M	A4AM/A4WM	Specify Volts, Frequency, with Honeywell or Penn Motor	23-11
1:1 Pneumatically Compensated	P	A4AP/A4WP	See Bulletin	23-08
3:1 Pneumatically Compensated	3P	A4A3P A4W3P	See Bulletin	23-08
Temperature Operated	T	A4AT/A4WT	Specify Range Standard Range -30° to +30°C High Range +20° to +60°C -20° to +80°F +60° to +140°F	23-09
Electronic Pilot Operated	J	A4AJ	Order controller separately.	23-12
Externally Equalized	E	A4AE/A4WE	Specify Range	23-05
Main Regulator for Remote Pilot	R	A4AR/A4WR	Main regulator only. Add pilots from page 14.	23-05
Complete Regulator Assembly w/ Modudapter®	Z	A4AZ	2 Modupluates included. Order Modules from pages 6-7.	23-06
Low Pressure Drop	LPD	A4A-LPD A4W-LPD	Describe system requirements	23-100

To Order:

Specify Port Size, Type, Range, Flange Size, Flange Style, and if with Strainer, Gauge and Gauge Valve.

If B, S or D variation is included, specify Volts and Frequency.

Examples:

40mm A4A, range A, 1½" WN with strainer, gauge and gauge valve.

1¼" A4AD, ranges A/A, 1¼" SW with strainer, gauge and gauge valve, 120/60Hz.

A4A, A4W Pressure Ranges:

A = 0 to 10.3 bar (0 to 150 PSIG) – Standard

V = 50m Hg to 8.3 bar (20 in Hg to 120 PSIG)

D = 5.2 to 29.3 bar (75 to 280 PSIG)

A4AO: Standard range is V; range D available.



Electric Proportioning Thermostat (T27)

Use with "M" variation regulators.

Specifications:

Range -34° to 21°C (-30° to 70°F)
 Capillary 1.5m (5') standard
 Bulb 12.7mm dia. x 106mm long
 (½" dia. x 4¾" long)
 Sensitivity adjustable 1.7° to 16.7°C
 (3° to 30°F)
 Various electronic controllers available



To Order:

Specify: Type T27.

Defrost Timer (T31)

- U.L. listed
- Adjustable for defrost in 3-hour multiples
- Separate adjustable pump down cycle
- Separate adjustable fan delay cycle
- Contact ratings 10 amps
- Standard NEMA-3 housing



To Order:

Specify: Type T31 (115V 60 Hz) or T31A (208-240V 60 Hz)

Well, Separable

For use with T27 Thermostat **Part Number**
 Stainless steel, 3/8" x 5" 301800

For use with temperature operated valves (A4T) **Part Number**
 Stainless steel, 5/8" x 3" 305349
 Steel, 5/8" x 3" 203237

Flange Ring-Tube Kits (FRT)

Use with "L" and "O" variation regulators

Close couples to the valve outlet. Eliminates the need for field piping.



Electronic Accessories

Use with "J" variation regulators

Controllers	Part #
4-20mA	105624
0-18 VDC	105625
Transformer	Part #
240/24	301787
120/24	301788

R-22

Evap Temp °C Evap Press, bar	Pressure Drop, bar	20mm A4A⊗	25mm A4A	32mm A4A	40mm A4A	50mm A4A	65mm A4A	75mm A4A	100mm A4A	125mm A4W	150mm A4W	200mm A4W
10° 5.8	0.14 0.7	19 42	27 58	44 95	77 170	130 280	180 400	240 530	360 780	490 1100	880 1900	1300 2900
5° 4.8	0.14 0.7	18 39	24 53	40 87	71 150	120 260	170 360	220 480	330 710	450 970	800 1700	1200 2700
0° 4.0	0.14 0.7	16 35	22 48	37 79	65 140	110 230	150 330	200 440	300 640	410 880	730 1600	1100 2400
-5° 3.2	0.14 0.7	15 32	20 43	33 71	59 130	100 210	140 300	190 400	270 580	370 800	670 1400	1000 2200
-10° 2.5	0.14 0.7	13 29	18 39	30 64	54 110	90 190	130 270	170 360	250 520	340 710	610 1300	930 2000
-15° 1.9	0.14 0.7	12 25	17 35	27 57	48 100	81 170	110 240	150 320	220 470	300 640	550 1100	840 1800
-20° 1.4	0.14 0.35	11 17	15 23	25 38	44 67	70 110	100 160	140 210	200 310	270 420	490 760	750 1200
-25° 1.0	0.14 0.35	10 15	13 20	22 34	39 60	70 100	90 140	120 190	180 270	240 370	440 670	670 1000
-30° 0.63	0.035① 0.14	4.4 8.7	6.0 12	9.9 20	18 35	30 58	42 82	55 110	81 160	110 220	200 390	300 600
-35° 0.31	0.035① 0.14	3.9 7.7	5.4 10	8.8 17	16 31	26 51	37 72	49 100	72 140	100 190	180 350	270 530
-40° 0.04	0.035① 0.14	3.5 6.7	4.7 9.2	7.8 15	14 27	23 45	33 63	43 84	64 120	87 170	160 300	240 460

R-717

Evap Temp, °C Evap Press, bar	Pressure Drop, bar	20mm A4A⊗	25mm A4A	32mm A4A	40mm A4A	50mm A4A	65mm A4A	75mm A4A	100mm A4A	125mm A4W	150mm A4W	200mm A4W
10° 5.1	0.14 0.35 0.70 1.40	54 84 120 160	73 110 160 220	120 190 260 360	210 340 470 630	360 560 780 1100	500 790 1100 1500	670 1100 1500 2000	990 1500 2100 2900	1300 2100 2900 4000	2400 3800 5300 7200	3700 5800 8100 11000
5° 4.1	0.14 0.35 0.70 1.40	49 77 110 140	67 100 150 190	110 170 240 320	200 310 420 570	330 510 710 950	460 720 1000 1300	620 960 1300 1800	900 1400 2000 2600	1200 1900 2700 3600	2200 3500 4800 6400	3400 5300 7300 9800
0° 3.3	0.14 0.35 0.70	45 70 100	61 95 130	100 160 220	180 280 380	300 470 640	420 660 900	560 870 1200	820 1300 1800	1100 1700 2400	2000 3100 4300	3100 4800 6600
-5° 2.5	0.14 0.35 0.70	41 63 86	55 86 120	91 140 190	160 250 340	270 420 580	380 590 810	510 790 1100	750 1200 1600	1000 1600 2200	1800 2800 3900	2800= 4300 5900
-10° 1.9	0.14 0.35 0.70	37 57 77	50 77 100	82 130 170	150 230 310	240 380 510	340 530 720	460 710 960	670 1000 1400	920 1400 1900	1700 2600 3500	2500 3900 5300
-15° 1.3	0.14 0.21 0.35	33 40 51	45 55 69	74 90 110	130 160 200	220 270 340	310 380 480	410 500 640	600 730 930	830 1000 1300	1500 1800 2300	2300 2800 3500
-20° 0.89	0.035 0.14 0.21	15 29 36	20 40 49	34 66 80	60 120 140	100 200 240	140 280 340	190 370 450	270 540 650	370 740 890	700 1300 1600	1000 2000 2500
-25° 0.50	0.035① 0.14	13 26	18 36	30 59	53 100	89 170	125 250	170 330	240 480	330 660	600 1200	920 1800
-30° 0.18	0.035① 0.14	12 23	16 31	27 52	47 92	79 150	110 220	150 290	220 400	300 600	530 1000	820 1600
-35° -0.08	0.035① 0.14	10 20	14 28	23 45	42 80	70 130	98 190	130 250	190 370	260 510	470 910	720 1400
-40° -0.30	0.035 0.14	9.1 17	12 24	21 39	36 70	61 120	86 160	110 220	170 320	230 440	410 790	630 1200

Capacities for R22 are based on 40°C liquid and 5°C superheat entering the regulator. R717 based on 30°C liquid. Capacities are maximum and have no reserve for excess loads. Capacities apply to any A4A or A4W regulator (or S4A and S4W) regardless of variation used.

Sub-cooled liquid: For each 5°C liquid is colder than base temperature, INCREASE TABLE VALUES by 4% for R22 and 3% for R717.

① 0.035 bar pressure drop capacities apply only to regulators with LPD (low pressure drop) Variation.

② 20mm regulator is available with throttling plug capacities equivalent to approximately 50% and 17% of the ratings in the tables.

Note: For liquid overfeed applications (nominal 2:1 to 5:1 ratio), add 20% to the evaporator load and select a regulator based on this increased load value.



R-22

Evap Temp °F Evap Press PSI	Pressure Drop, PSI	¾"	1"	1¼"	1½"	2"	2½"	3"	4"	5"	6"	8"
		A4A⊙	A4A	A4A	A4A	A4A	A4A	A4A	A4A	A4W	A4W	A4W
50°F 84.1	2 10	5.6 12	7.6 17	13 27	22 49	37 81	53 110	70 150	103 220	140 310	252 550	385 840
40°F 68.6	2 10	5.1 11	6.9 15	11 25	20 44	34 73	48 100	64 140	93 200	127 280	229 500	350 760
30°F 55.0	2 10	4.6 10	6.3 14	10 22	18 39	31 66	43 93	57 120	84 180	115 250	207 450	316 680
20°F 43.1	2 10	4.1 8.8	5.6 12	9.3 20	16 35	28 59	39 83	52 110	76 160	100 220	190 400	280 610
10°F 32.8	2 10	3.7 7.8	5.1 11	8.3 18	15 31	25 52	35 74	46 98	68 140	93 200	170 350	260 540
0°F 24.0	2 5	3.3 5.1	4.5 7.0	7.4 11	13 20	22 34	31 48	41 64	61 93	83 130	150 230	230 350
-10°F 16.5	2 5	2.9 4.5	4.0 6.1	6.6 10	12 18	20 30	27 42	37 56	54 82	73 112	130 200	200 310
-20°F 10.2	0.5⊙ 2	1.3 2.6	1.8 3.5	2.9 5.8	5.2 10	8.7 17	12 24	16 32	24 47	33 64	59 120	90 180
-30°F 4.9	0.5⊙ 2	1.1 2.2	1.6 3.1	2.6 5.1	4.6 9.0	7.7 15	11 21	14 28	21 41	29 56	52 100	79 150
-40°F 0.6	0.5⊙ 2	1.0 1.9	1.4 2.7	2.3 4.4	4.0 7.8	6.7 13	9.4 18	13 24	18 36	25 49	45 88	69 130

R-717

Evap Temp, °F Evap Press PSI	Pressure Drop, PSI	¾"	1"	1¼"	1½"	2"	2½"	3"	4"	5"	6"	8"
		A4A⊙	A4A	A4A	A4A	A4A	A4A	A4A	A4A	A4W	A4W	A4W
50°F 74.5	2 5 10 20	16 25 35 47	22 34 47 64	36 56 78 110	63 99 140 190	110 170 230 310	150 230 320 440	200 310 430 590	290 460 630 860	400 620 860 1200	720 1120 1560 2100	1090 1710 2380 3200
40°F 58.6	2 5 10 20	14 22 31 42	20 31 42 57	32 50 70 94	57 90 120 170	96 150 210 280	130 210 290 390	180 280 390 520	260 410 570 770	360 560 780 1000	650 1000 1400 1900	990 1500 2100 2900
30°F 45.0	2 5 10	13 20 28	18 28 38	29 45 62	52 80 110	86 130 190	120 190 260	160 250 350	240 370 510	320 510 700	580 910 1300	890 1400 1900
20°F 33.5	2 5 10	12 18 25	16 25 34	26 40 55	46 72 98	77 120 160	110 170 230	150 230 310	210 330 450	290 450 620	520 810 1100	800 1200 1700
10°F 23.8	2 5 10	10 16 22	14 22 29	23 36 48	41 64 86	69 110 140	97 150 200	130 200 270	190 290 400	260 400 540	470 720 970	710 1100 1500
0°F 15.7	2 3 5	9.2 11 14	13 15 19	21 25 32	37 44 56	61 74 94	86 100 130	110 140 180	170 200 260	230 280 350	410 500 630	630 770 970
-10°F 9.0	0.5⊙ 2 3	4.1 8.1 9.7	5.6 11 13	9.2 18 22	16 32 39	27 54 65	39 76 91	51 100 120	75 150 180	100 200 240	180 360 440	280 550 670
-20°F 3.6	0.5⊙ 2	3.6 7.0	4.9 9.6	8.1 16	14 28	24 47	34 66	45 88	66 130	90 180	160 320	250 480
-30°F -0.8	0.5⊙ 2	3.1 6.1	4.3 8.3	7.0 14	12 24	21 40	29 57	39 76	57 110	78 150	140 270	220 420
-40°F -4.3	0.5⊙ 2	2.7 5.2	3.7 7.1	6.1 12	11 21	18 34	25 49	34 65	50 95	68 130	120 230	190 360

Capacities for R22 are based on 100°F liquid and 10°F superheat entering the regulator. R717 based on 86°F liquid. Capacities are maximum and have no reserve for excess loads. Capacities apply to any A4A or A4W regulator (or S4A and S4W) regardless of variation used.

Sub-cooled liquid: For each 10°F liquid is colder than base temperature, INCREASE TABLE VALUES by 4% for R22 and 3% for R717.

⊙ 0.5 psi pressure drop capacities apply only to regulators with LPD (low pressure drop) Variation.

⊙ ¾" regulator is available with throttling plug capacities equivalent to approximately 50% and 17% of the ratings in the tables.

Note: For liquid overfeed applications (nominal 2:1 to 5:1 ratio), add 20% to the evaporator load and select a regulator based on this increased load value.



Liquid Capacities (KW)

Typical Application: A4AL as pump relief regulator

	For 4°C Liquid ①				
	Port Size	0.7 bar Pressure Drop		1.4 bar Pressure Drop	
		kg/min	m³/hr	kg/min	m³/hr
R22	20mm	110	5.1	150	7.2
	25mm	150	7.0	210	9.9
	32mm	240	12	340	16
	40mm	430	20	610	29
	50mm	720	34	1020	48
	65mm	1000	48	1440	68
	75mm	1400	64	1920	91
R717	20mm	77	7.3	108	10
	25mm	100	9.9	150	14
	32mm	170	16	240	23
	40mm	310	29	430	41
	50mm	510	48	720	68
	65mm	720	68	1000	96
	75mm	960	91	1400	130

① Correction factors for temperatures between -40°C and 30°C are negligible.

Oil Capacities (m³/h)

Typical Application: Screw compressor oil feed control

Port Size	For 30° to 50°C Oil (300 SSU Viscosity) and Pressure Drops Listed①		
	0.3 bar	0.7 bar	3.0 bar
20mm	3.9	5.4	12
25mm	5.4	7.5	17
32mm	9.3	13	30
40mm	18	25	57
50mm	27	36	84
65mm	39	52	120
75mm	54	75	170

① Based on no foaming of oil through regulator.

Hot Gas Bypass Capacities (KW)

Typical Application: Compressor suction loading

R22	Condensing Temp	Discharging Temp	20mm A4AO①	25mm A4AO	32mm A4AO	40mm A4AO	50mm A4AO	65mm A4AO	75mm A4AO
	30°C	80°C	120	200	350	570	1000	1400	1900
	40°C	80°C	140	240	400	660	1200	1600	2200
	45°C	80°C	160	260	440	720	1300	1700	2400
	50°C	80°C	170	280	480	780	1400	1900	2600

Capacities are average for the condensing temperatures and the corresponding discharge temperatures listed. Liquid temperature is the same as condensing temperature; evaporator temperature 5°C or less. Use at other reasonable conditions usually requires no capacity correction.

① The 20mm Port Size Type A4AO Regulator is available with reduced throttling plug capacities equivalent to approximately 50% and 17% of the ratings shown here.

	Port Size②	Inlet Pressure	
		2 bar	11 bar
		Outlet Pressure Range	
		0-45 cm Hg	3bar to 45 cm Hg
R717	20mm	120	380
	25mm	160	530
	32mm	290	930
	40mm	550	180
	50mm	810	2600
	65mm	1100	3700
	75mm	1600	5300

Based on near saturated inlet gas and 11 bar ratings for 30°C condensing, 2 bar ratings for -7° condensing. Correction not essential for other gas or liquid temperatures.

② For capacities of larger regulators or other conditions, contact factory. Flow coefficients for all sizes are shown on page 8 and may be used for other flow calculations and for larger regulators.

Liquid Capacities (US Tons)

Typical Application: A4AL as pump relief regulator

	For 40°F Liquid ①				
	Port Size	10 psi Pressure Drop		20 psi Pressure Drop	
		lb/min	gpm	lb/min	gpm
R22	3/4	240	22	330	32
	1	320	31	460	43
	1-1/4	530	50	750	71
	1-5/8	950	89	1400	130
	2	1600	150	2200	210
	2-1/2	2200	210	3200	300
	3	3000	280	4200	400
R717	3/4	170	32	240	45
	1	230	43	320	61
	1-1/4	380	71	530	100
	1-5/8	690	130	950	180
	2	1100	210	1600	300
	2-1/2	1600	300	2200	420
	3	2100	400	3000	560

① Correction factors for temperatures between -40°F and 86°F are negligible.

Oil Capacities (gpm)

Typical Application: Screw compressor oil feed control

Port Size	For 85° to 120°F Oil (300 SSU Viscosity) and Pressure Drops Listed①		
	5.0 psi	10 psi	50 psi
3/4"	17	24	54
1"	24	33	74
1 1/4"	41	58	130
1 5/8"	79	110	250
2"	120	160	370
2 1/2"	170	230	520
3"	240	330	750

① Based on no foaming of oil through regulator.

Hot Gas Bypass Capacities (US Tons)

Typical Application: Compressor suction loading

R22	Condensing Temp, °F	Discharging Temp, °F	3/4" A4AO①	1" A4AO	1 1/4" A4AO	1 5/8" A4AO	2" A4AO	2 1/2" A4AO	3" A4AO
	86°	180°	35	58	99	160	290	380	550
	100°	180°	41	67	110	190	330	440	630
	110°	180°	44	73	130	200	370	480	690
	120°	180°	48	79	140	220	400	530	750

Capacities are average for the condensing temperatures and the corresponding discharge temperatures listed. Liquid temperature is the same as condensing temperature; evaporator temperature 40°F or less. Use at other reasonable conditions usually requires no capacity correction.

① The 3/4" Port Size Type A4AO Regulator is available with reduced throttling plug capacities equivalent to approximately 50% and 17% of the ratings shown here.

	Port Size②	Inlet Pressure	
		30 psig	150 psig
		Outlet Pressure Range	
		0-15 in Hg	45 psig to 15 in Hg
R717	3/4"	34	110
	1"	47	150
	1 1/4"	82	270
	1 5/8"	160	510
	2"	230	760
	2 1/2"	330	1100
	3"	470	1500

Based on saturated inlet gas.

② For capacities of larger regulators or other conditions, contact factory. Flow coefficients for all sizes are shown on page 8 and may be used for other flow calculations and for larger regulators.

Type A2B, S6N

Function

One main regulator can be controlled by combinations of remote regulators and solenoids to provide a variety of functions. Because of the high cost of installation and the possibility of error in field remote piping, the A4A Series of self-contained regulators is preferred. (See pages 3 to 9).

Applications

Typical applications include:

- **Main regulator in an inaccessible location.** Pilot can be located where it can be adjusted and serviced conveniently.
- **When better environment is required.** Remote pilots can solve electrical or pneumatic variation problems.

Typical Remote Combinations

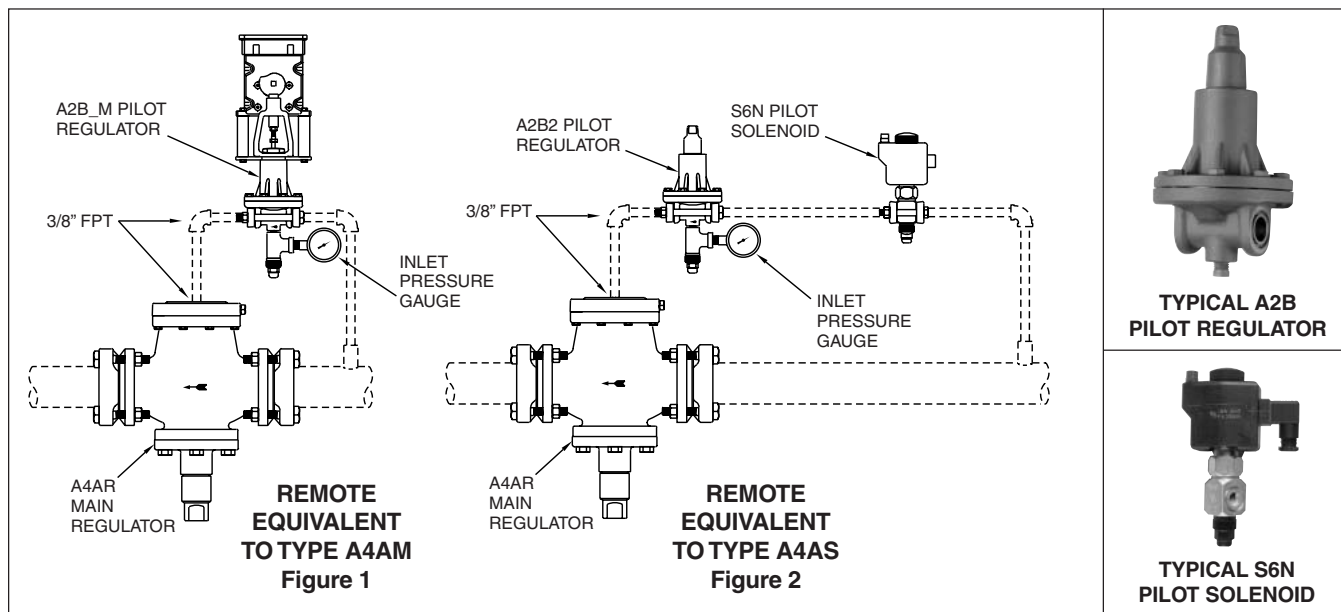

Ordering Guide

Type	Description	For Use with Main Valve Size & Type	Ranges Available Std. is Bold	Connections Available Ø Style: FPT, SW, WN	Net Weight	
					kg	lbs
A2B2	Inlet Pressure Pilot Regulator	20-50mm (¾" - 2") A4AR	V, A, D	⅜", ½", ¾"	3.6	8
A2B	Inlet Pressure Pilot Regulator	65-100mm (2½" - 4") A4AR 125-200mm (5" - 8") A4WR				
A2BO2E	Outlet Pressure Regulator	20-50mm (¾" - 2") A4AR	V, D	⅜", ½", ¾"	3.6	8
A2BO4E	Outlet Pressure Regulator	65-100mm (2½" - 4") A4AR 125-200mm (5" - 8") A4WR				
⅜" S6N	Pilot Solenoid	20-100mm (¾" to 4") A4AR	See pg. 7 for voltages	⅜", ½", ¾"	2.5	5

A2B2 and A2B Ranges: A (Standard) = 0 to 10.3 bar (0 to 150 psig); V = 500mm Hg to 8.3 bar (20 in Hg to 120 psig); D = 5.2 to 19.3 bar (75 to 280 psig)

All of the Pilot Regulators above are available as compensated controls. For Electrically Compensated, add suffix "M", as A2B2M; for Pneumatically Compensated, add suffix "P" or "3P", as A2B2P or A2B23P; for Temperature Compensated, add suffix "T", as A2BT. Temperature range and scale is -30°C to 30°C (-20°F to 80°F).

① ⅜" FPT is standard and will be furnished unless specified otherwise.

A2BO2E and A2BO4E Ranges: V (Standard) = 500mm Hg to 8.3 bar (20 in Hg to 120 psig); D = 5.2 to 19.3 bar (75 to 280 psig)

See page 8 to order A4AR or A4WR main regulator. Any of the A4A or A4W regulators with or without added variations are available as a remote regulator by using an A4AR 20-100mm (¾" to 4") or A4WR 125-200mm (5" - 8") main valve with the suitable pilots.

Figure #1 (see above): The remote equivalent to a 75mm (3") Type A4AM would use a 75mm (3") A4AR main valve with a A2BM pilot regulator. Figure #2 (see above): The remote equivalent to a 50mm (2") Type A4AS would use a 50mm (2") A4AR main valve with a A2B2 pilot regulator with an S6N pilot solenoid piped in series.

To Order:

Pilot Regulator:

Specify regulator type, range, flange size, flange style and if with strainer, gauge and gauge valve.

Example: A2B2, Range A, ½" FPT

Pilot Solenoid:

Specify port size, valve type, flange size, flange style, volts and frequency, and if with strainer.

Example: S6N with strainer, ⅜" FPT, 120/60.

Description

The A2 type pressure regulators are compact, direct diaphragm operated regulators are for use in systems where a small inlet or outlet pressure regulator is needed.

Materials

Body Gray iron
 Seat Chrome plated
 Diaphragm Stainless steel preformed

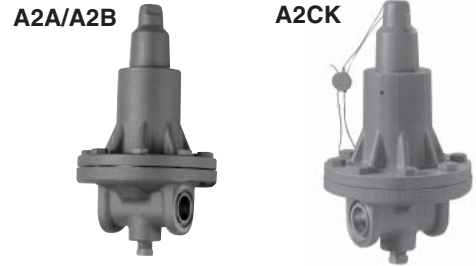

Specifications

Maximum Fluid Temperature 105°C (220°F)
 Minimum Fluid Temperature -45°C (-50°F)
 Design Pressure (MRP) 27.6 bar (400 PSIG)

Application and Selection Guide

Type	Function	Operation	Typical Applications
A2B	Control inlet pressure	Regulate at preset inlet pressure Field adjustable	1. Small capacity back pressure regulator 2. Small capacity defrost relief regulator
A2A	Inlet regulator, greater capacity	Open on rise in inlet pressure	
A2BO	Control outlet pressure	Regulate at preset outlet pressure Field adjustable Open on drop in outlet pressure	1. Gas pressure reducing regulator 2. Liquid or oil pressure reducing regulator
A2CK①	Relief regulator.	Regulate inlet pressure. Factory set.	1. Prevent hydrostatic pressure build-up in isolated sections of liquid lines.

① The design of the A2CK valve allows for higher flow and a "quick release" feature. However, it does not offer the same type of controlled response which may be required for a standard regulator application. For those applications where a small regulator is needed for accurate upstream pressure control, an A2A or A2B direct operated regulator should be considered.

Ordering Guide

Type	Description	Ranges Available (Std. is Bold)	Connections Available ③ Style: FPT, SW, WN	Flow④ Coefficient		Net Weight			
						Less Strainer		With Strainer	
						Kv	Cv	kg	lb
A2B	Small Capacity Back Pressure Regulator	V, A, D		0.43	0.5	3.6	8	4.5	10
A2BK①	Relief, Give pressure setting	A, D	¼", ⅜", ½", ¾"	0.34	0.4	3.6	8	4.5	10
A2BP	Differential Regulator for ext. connection	A, D		0.43	0.5	3.6	8	4.5	10
A2BM	Electrically Compensated	V, A, D							
A2BT	Temperature Operated Regulator	1, 2	¼", ⅜", ½", ¾"						
A2A	Small Capacity Back Pressure Regulator	A, D	¼", ⅜", ½", ¾"	1.28	1.5	3.6	8	4.5	10
A2BO1②	Small Capacity Outlet Pressure Regulator	V, D	¼", ⅜", ½", ¾"	0.09	0.1	3.6	8	4.5	10
A2BO2②				0.17	0.2	3.6	8	4.5	10
A2BO4②				0.43	0.5	3.6	8	4.5	10
A2CK	Relief Regulator – Liquid Lines	D	¼", ⅜", ½", ¾"	0.97	1.14	3.6	8	4.5	10

① The A2BK Reseating Relief Regulator can be used for various relief to low side applications including cold liquid line sections where buildup of dangerous hydrostatic pressure is possible. See "Safe Operation" on the back cover.

② Specify for external pressure connection.

③ Bold face type is standard size. FPT will be furnished unless specified otherwise.

④ Flow coefficients are for standard range.
 Ranges V = 500mm Hg to 8.3 bar (20 in Hg to 120 psig);
 A = 0 to 10.3 bar (0 to 150 psig); D = 5.2 to 19.3 bar (75 to 280 psig)

To Order

Specify: Type, Range, Flange Size, Flange Style, if with Strainer, Gauge and Gauge Valve.

Example: A2B, range A, ¾" WN, with strainer, Q116 gauge, V12 gauge valve.

Capacities (KW)

	Type	ΔP, bar	-40°C	-30°C	-20°C	-10°C	0°C
R22	A2B	0.14	0.42	0.53	0.67	0.84	1.0
	A2A		1.3	1.6	2.0	2.5	3.0
R717	A2B	0.14	1.1	1.5	1.9	2.4	2.9
	A2A		3.3	4.6	5.6	7.3	8.9
	A2B	0.34	1.8	2.3	3.0	3.8	4.7
	A2A		5.3	7.3	8.8	11	14
	A2B	0.70	2.5	3.3	4.2	5.4	6.7
	A2A		7.4	10	12	16	20

Capacities (US Tons)

	Type	ΔP, psi	-40°F	-20°F	0°F	+20°F	+40°F
R22	A2B	2	0.12	0.16	0.20	0.26	0.32
	A2A		0.36	0.47	0.61	0.77	0.96
R717	A2B	2	0.32	0.44	0.58	0.74	0.93
	A2A		0.95	1.3	1.7	2.2	2.8
	A2B	5	0.50	0.67	0.89	1.2	1.4
	A2A		1.5	2.0	2.7	3.4	4.3
	A2B	10	0.71	0.98	1.2	1.6	2.0
	A2A		2.1	2.9	3.7	4.7	6.0

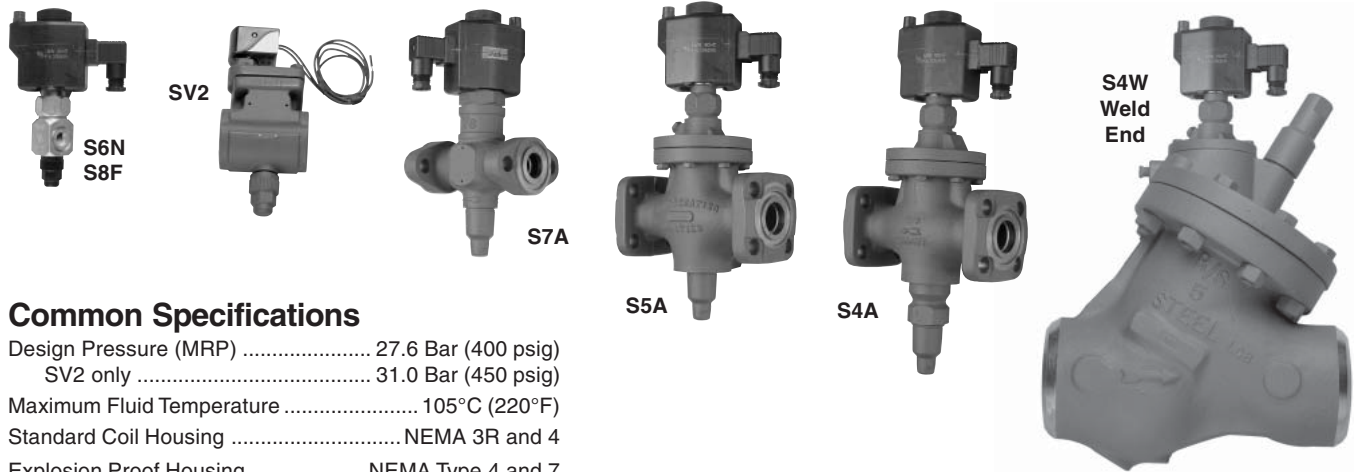

Common Specifications

Design Pressure (MRP) 27.6 Bar (400 psig)
 SV2 only 31.0 Bar (450 psig)
 Maximum Fluid Temperature 105°C (220°F)
 Standard Coil Housing NEMA 3R and 4
 Explosion Proof Housing NEMA Type 4 and 7

Application Guide

Valve Type	Refrigerant Application	Refrigerant Temperature Range	VALVE MOST RECOMMENDED – Listed by Port Size										
			5mm	13mm	20mm	25mm	32mm	40mm	50mm	65mm	75mm	100mm	125-200mm
			3/16"	1/2"	3/4"	1"	1 1/4"	1 5/8"	2"	2 1/2"	3"	4"	5" - 8"
Solenoid	Liquid	Conventional warm high pressure	S6N	S8F SV2	S4A SV2	S4A SV2	S4A SV2	S4A	S4A	S4A	S4A	S4A	S4A
		Above -50°C (-60°F)	S6N	S8F	—	—	—	S4A	S4A	S4A	S4A	S4A	S4A
		Above -45°C (-50°F)	S6N	S8F SV2	S4A SV2	S4A SV2	S4A SV2	S4A	S4A	S4A	S4A	S4A	S4A
Solenoid	Suction*	Above -30°C (-25°F)	S6N	S8F	S7A	S7A	S5A	S5A	S5A	S5A	S5A	S4A	S4W
	Hot Gas Defrost	Below 105°C (220°F)	S6N	S8F SV2	S4A SV2	S4A SV2	S4A SV2	S4A	S4A	S4A	S4A	S4A	S4W
Solenoid	Bypass Compressor Unloading	Below 105°C (220°F)	S6N	S8F	S7A	S7A	S4AE	S4AE	S4AE	S4AE	S4AE	S4AE	—
Solenoid	Equalizing Lines		S6N	—	S7A	S7A	—	—	—	—	—	—	—

Specifications

Type		S6N	S8F	S7A	SV2	S5A	S5A	S4A	S4A	S4W
Port Size	mm	5	13	20-25	13-32	32	40-75	20-32	40-100	125-200
	inch	3/16"	1/2"	3/4" - 1"	1/2" - 1 1/4"	1 1/4"	1 5/8" - 3"	3/4" - 1 1/4"	1 5/8" - 4"	5" - 8"
Seat Material		PTFE	PTFE	PTFE	PTFE	PTFE	Metal	PTFE	Metal	Metal
Body Material		Ductile Iron	Ductile Iron	Gray Iron	Ductile Iron	Gray Iron	Gray Iron	Gray Iron	Gray Iron	Cast Steel
Minimum Pressure Drop to Open Wide	bar	0	0.7	0	.24	0.07	0.07	0.14	0.28	0.14
	psi	0	1	0	3.5	1	1	4	2	2
Minimum Fluid Temperature	°C	-50°	-50°	-30°	-45°	-30°	-30°	-45°	-50°	-50°
	°F	-60°	-60°	-25°	-50°	-25°	-25°	-50°	-60°	-60°
Bulletin for Reference		30-90	30-91	30-92	30-06	30-93	30-93	30-94	30-94	30-05

Coil Specifications

Class B Coils (used with all solenoids except SV2)

Volts/Hertz	Leads	Inrush Current (Amps)	Holding Current (Amps)	Fuse Size (Amps)
120/60	Blue	1.18	0.46	1
208/60	Blue and Red	0.63	0.26	1
240/60	Red	0.60	0.23	1
115/50	Yellow and Blue	1.22	0.21	1
230/50	Yellow	0.65	0.26	1

Class H Coils (used with SV2 only)

Coil Type	Watt Rating	Volt Amperage	
		Holding	Inrush
Standard AC Class "H"	10.5	23	37
Standard AC Coil with 6v Secondary Pilot Light	11.0	26	38

Selection Guide

Port Size		Type	Description	Flow Coefficient		Available Connections			Net Weight			
mm	Inch			Kv	Cv	FPT, SW, WN	ODS	DIN WN	Less Strainer		With Strainer	
5mm	3/16	S6N	Direct Operated	0.5	0.6	¼", ⅜", ½", ¾"	½", ⅝", ⅞"	10, 15, 20	2.5	5	3.3	7
13mm	1/2	S8F	Spring Closing	2.3	2.7	¼", ⅜", ½", ¾"	½", ⅝", ⅞"	10, 15, 20	2.5	5	3.3	7
		SV2	Spring Closing	2.6	3.0				1.8	4	2.7	6
20mm	3/4	SV2	Spring Closing	6.0	7.0	¾", 1", 1¼"	⅞", 1⅛", 1⅝"	20, 25, 32	9.5	20	13	27
		S4A	Spring Closing	6.9	8.1				5.5	11	8.6	18
		S7A	Elec. Held Open	8.7	10				4.0	9	7.2	16
25mm	1	S4A	Spring Closing	8.4	9.9	¾", 1", 1¼"	⅞", 1⅛", 1⅝"	20, 25, 32	9.5	20	14	27
		S7A	Elec. Held Open	9.2	11				5.5	11	8.6	18
		SV2	Spring Closing	10	12				4.0	9	7.2	16
32mm	1¼	S4A	Spring Closing	17	20	1¼", 1½"	1⅝", 1⅞", 2⅛"	32, 40	15	31	21	46
		S5A	Gravity Closing	16	19				14	29	20	44
		SV2	Spring Closing	16	19				6.8	15	14	30
40mm	1⅝	S4A	Spring Closing	27	32	1½", 2"	1⅝", 2⅛", 2⅝"	40, 50	30	64	43	94
		S5A	Gravity Closing	32	37				28	60	41	90
50mm	2	S4A	Spring Closing	46	53	1½", 2"	1⅝", 2⅛", 2⅝"	40, 50	30	64	43	94
		S5A	Gravity Closing	44	51				28	61	41	90
65mm	2½"	S4A	Spring Closing	64	75	2½", 3" (No FPT)	2⅝", 3⅞"	65, 75	38	81	63	137
		S5A	Gravity Closing	70	82				36	77	61	133
75mm	3	S4A	Spring Closing	86	100	3" (No FPT)	3⅞", 4⅝"	75	53	115	78	171
		S5A	Gravity Closing	98	120				51	110	76	166
100mm	4	S4A	Spring Closing	130	150	4" (No FPT)	4⅝"	100	72	156	121	264
125mm	5	S4W	Spring Closing	170	200	Weld End Only			52	114	95	209
150mm	6	S4W	Spring Closing	310	360	Weld End Only			94	204	169	371
200mm	8	S4W	Spring Closing	470	550	Weld End Only			152	333	281	618

S4A and S4W are available with ¼" FPT connection for EXTERNAL supply of actuating pressure. Specify S4AE or S4WE. S5A is available with ¼" FPT connection for external connection to outlet pressure. Specify S5AE. S4A, SV2 and S4W are available as EXPLOSION PROOF Solenoids and meet

the construction requirement of NEMA 4, 7 and 9. Specify S4AX, SV2X or S4WX. For SV2 with additional clearance between coil/housing assembly and body, specify SV2A.

To Order

Specify: Port Size, Type, Flange Size, Flange Style, Volts and Frequency, and if with Strainer. Standard connection sizes are in bold type and will be furnished unless otherwise specified.

Standard connections: FPT – 5 to 50mm (¾" - 2"); SW – 65 - 200mm (2 ½" - 4"); Weld End – 125 to 200mm (5" - 8").

Examples: ½" SV2, ½" FPT, 120V 60Hz, with strainer. 32mm S4A, 1¼" WN, 230V 50Hz.

Voltages

Non-standard voltages (shown in shaded area of table) can be special ordered. Coils with 6V secondary voltage for use with remote pilot lights PLT-1 and PLT-2.

NOTE: Pilot lights cannot be used with explosion proof or unleaded (DIN connector) coils.

■ These voltages for the Class "H" coils are 120/60-110/50, 240/60-220/50, 480/60-440/50.

Available Voltages for Coils and Remote Pilot Lights	Class	120/60	120/6/60	208/60	208/6/60	240/60	240/6/60	115/50	230/50	240/50	24/60	480/60	24/50	48/50	24VDC	120VDC	48VDC
		Encapsulated w/Leads	B	●	●	●	●	●	●		●		●		●	●	
Encapsulated w/Leads & Integral Pilot Light	B	●		●		●											
Encapsulated w/DIN Connector	B	●				●		●	●	●					●		●
Encapsulated w/DIN & Integral Pilot Light	B	●						●	●	●							
Explosion Proof	-	●		●		●		●	●		●	●			●	●	
Compact Operator w/Leads (SV2 only)	H	■		●		■		●	●	●	●	■	●		●		
Compact Operator w/DIN (SV2 only)	H	■		●		■		●	●	●	●	■	●				
Remote Pilot Light PLT-1 (NEMA 1)			●		●		●										
Remote Pilot Light PLT-2 (NEMA 4)			●		●		●										
Remote Pilot Light PLT-5 (NEMA 4)		●		●		●											

NOTE: Class B coils are used on all industrial solenoids except the SV2. Class H coils are used with the SV2 only.



	Port Size (mm)	Type	Liquid Capacities ^①		Suction Capacities ^②				Hot Gas Reclaim ^③					
			0.14 bar pressure drop	0.27 bar pressure drop	0.07 bar pressure drop		0.14 bar pressure drop		32°C Condensing		43°C Condensing		54°C Condensing	
					-10°C	-20°C	-10°C	-20°C	0.24 bar pr. drop	0.34 bar pr. drop	0.24 bar pr. drop	0.34 bar pr. drop	0.24 bar pr. drop	0.34 bar pr. drop
R22	5 mm	S6N	9.0	12	0.72	0.59	1.0	0.83	—	—	—	—	—	—
	13 mm	S8F SV2	41 —	56 62	3.2 —	2.7 —	4.6 —	3.8 —	14	17	15	18	16	19
	20 mm	S4A ^⑤	120	170	—	—	—	—	39	46	41	49	44	52
		S7A SV2	150 —	210 150	12 —	10 —	17 —	14 —	— 33	— 40	— 36	— 43	— 38	— 45
	25 mm	S4A	150	210	—	—	—	—	47	56	51	60	53	63
		S7A SV2	160 —	220 250	13 —	11 —	18 —	15 —	— 57	— 68	— 62	— 73	— 65	— 77
	32 mm	S4A	300	420	—	—	—	—	96	110	103	120	110	130
		S5A SV2	290 —	400 400	23 —	19 —	32 —	26 —	— 91	— 110	— 98	— 120	— 100	— 120
	40 mm	S4A	480	660	—	—	54	44	150	180	160	190	170	200
		S5A	560	770	45	36	63	51	—	—	—	—	—	—
	50 mm	S4A	800	1100	—	—	91	74	250	300	270	330	290	340
		S5A	770	1100	61	50	87	71	—	—	—	—	—	—
	65 mm	S4A	1100	1600	—	—	130	100	360	430	380	460	410	480
		S5A	1200	1700	99	81	140	110	—	—	—	—	—	—
75 mm	S4A	1500	2100	—	—	170	140	480	570	510	610	540	640	
	S5A	1700	2400	140	110	200	160	—	—	—	—	—	—	
100 mm	S4A	2200	3100	—	—	—	—	700	830	750	890	790	940	
125 mm	S4W	—	—	—	—	—	—	960	1100	1000	1200	1100	1300	
150 mm	S4W	—	—	—	—	—	—	1700	2000	1800	2200	1900	2300	
200 mm	S4W	—	—	—	—	—	—	2600	3100	2800	3400	3000	3500	
R717								21°C Condensing		30°C Condensing				
								0.24 bar	0.34 bar	0.24 bar	0.34 bar			
	5 mm	S6N	55	77	—	—	—	—	—	—	—	—	—	
	13 mm	S8F	250	350	9.3	7.5	13	11	—	—	—	—	—	—
		SV2	—	380	—	—	—	—	35	41	38	46	—	—
	20 mm	S4A ^⑤	—	1000	—	—	—	—	93	110	100	120	—	—
		S7A SV2	940 —	1300 900	35 —	28 —	50 —	40 —	— 81	— 96	— 90	— 110	—	—
	25 mm	S4A	—	1300	—	—	—	—	110	140	130	150	—	—
		S7A SV2	990 —	1400 1500	37 —	30 —	52 —	42 —	— 140	— 170	— 150	— 180	—	—
	32 mm	S4A	—	2600	—	—	—	—	230	280	260	300	—	—
		S5A SV2	1800 —	2400 2400	65 —	53 —	93 —	75 —	— 220	— 260	— 240	— 290	—	—
	40 mm	S4A	2900	4100	—	—	160	130	370	440	410	490	—	—
		S5A	3400	4700	130	100	180	150	—	—	—	—	—	—
	50 mm	S4A	4900	6800	—	—	260	210	620	730	680	810	—	—
S5A		4700	6500	180	140	250	200	—	—	—	—	—	—	
65 mm	S4A	6900	9600	—	—	370	300	870	1000	960	1100	—	—	
	S5A	7600	11000	280	230	400	320	—	—	—	—	—	—	
75 mm	S4A	9200	13000	—	—	490	390	1200	1400	1300	1500	—	—	
	S5A	11000	15000	400	320	560	450	—	—	—	—	—	—	
100 mm	S4A	14000	19000	Use CK-2 or S9A ^④	710	580	1700	2000	1900	2200	—	—	—	
125 mm	S4W	—	—	Use CK-2 or S9A ^④	970	790	2300	2800	2600	3000	—	—	—	
150 mm	S4W	—	—	Use CK-2 or S9A ^④	1800	1400	4200	5000	4600	5500	—	—	—	
200 mm	S4W	—	—	Use CK-2 or S9A ^④	2700	2200	6400	7600	7000	8400	—	—	—	

All capacities are maximum for the conditions listed and have no reserve for excess loads.

- ① **Liquid capacities for R22** are based on 40°C Condensing and 5°C evaporator temperatures with no flashing through the valve for the pressure drops listed. For each 5°C liquid is below 40°C, INCREASE values by 5%. **R717 capacities** are based on -7°C liquid with no flashing, -15°C evaporator temperature and no liquid overfeed. For liquid overfeed, multiply evaporator KW by recirculating rate and size valve to the KW result. Use of -7°C liquid for capacities in this table is sufficiently accurate for most liquid overfeed systems. To convert for 30°C input, multiply values in the table by 0.9.
- ② **Suction capacities for R22** are based on 40°C liquid and 5°C superheat entering the valve at the pressure drops and evaporator temperatures listed. For each 5°C liquid is below 40°C, INCREASE values by 5%. **R717 capacities** are based on 30°C condensing temperature and the evaporator temperatures listed. See A4A suction capacities on page 10 for other pressure drops and for corrections for liquid overfeed and sub-cooled liquid.
- ③ **Hot gas heat reclaim capacities** are in terms of heat of condensation rejected at the condenser and are based on saturated inlet conditions at pressures equivalent to the condensing temperatures and for the pressure drops listed.
- ④ **CK-2 and S9A**. See page 22 for low pressure drop at temperatures below -10°C.
- ⑤ **The 20mm port size S4A** is available with capacities equal to 50% of the ratings shown.



	Port Size (inch)	Type	Liquid Capacities ^①		Suction Capacities ^②				Hot Gas Reclaim ^③					
			2 psi pressure drop	4 psi pressure drop	1 psi pressure drop		2 psi pressure drop		90°F Condensing		110°F Condensing		130°F Condensing	
					20°F	0°F	20°F	0°F	3.5 psi pr. drop	5 psi pr. drop	3.5 psi pr. drop	5 psi pr. drop	3.5 psi pr. drop	5 psi pr. drop
R22	3/16	S6N	2.6	3.7	0.22	0.18	0.31	0.25	—	—	—	—	—	—
	1/2	S8F	12	17	1.0	0.79	1.4	1.1	—	—	—	—	—	—
		SV2	—	18	—	—	—	—	49	59	53	63	56	66
	3/4	S4A ^⑤	35	49	—	—	—	—	130	160	140	170	150	180
		S7A SV2	35	49	2.9	2.4	4.1	3.3	—	—	—	—	—	—
	1	S4A	43	60	—	—	—	—	160	190	170	210	180	220
		S7A SV2	43	61	3.7	2.9	5.2	4.2	—	—	—	—	—	—
	1¼	S4A	87	120	—	—	—	—	330	390	350	420	370	440
		S5A SV2	82	120	6.9	5.6	9.8	7.9	—	—	—	—	—	—
	1½	S4A	140	190	—	—	16	13	520	620	560	670	590	710
		S5A	160	230	14	11	19	15	—	—	—	—	—	—
	2	S4A	230	330	—	—	28	22	870	1040	940	1120	990	1180
S5A		220	310	19	15	26	21	—	—	—	—	—	—	
2½	S4A	320	460	—	—	39	31	1200	1500	1300	1600	1400	1700	
	S5A	350	500	30	24	42	34	—	—	—	—	—	—	
3	S4A	430	610	—	—	52	42	1600	2000	1800	2100	1900	2200	
	S5A	500	700	42	34	59	48	—	—	—	—	—	—	
4	S4A	630	900	—	—	—	—	2400	2900	2600	3100	2700	3200	
5	S4W	—	—	—	—	—	—	3300	3900	3500	4200	3700	4400	
6	S4W	—	—	—	—	—	—	5900	7000	6300	7600	6700	8000	
8	S4W	—	—	—	—	—	—	9000	11000	9700	12000	10200	12000	
R717								70°F Condensing		86°F Condensing				
								3.5 psi	5 psi	3.5 psi	5 psi			
	3/16	S6N	16	22	—	—	—	—	—	—	—	—	—	
	1/2	S8F	70	99	2.8	2.2	4.0	3.0	—	—	—	—	—	—
		SV2	—	110	—	—	—	—	120	140	130	160	—	—
	3/4	S4A ^⑤	—	300	—	—	—	—	320	380	350	420	—	—
		S7A SV2	210	290	8.3	6.6	12	9.0	—	—	—	—	—	—
	1	S4A	—	360	—	—	—	—	390	470	430	520	—	—
		S7A SV2	260	370	10	8.3	15	11	—	—	—	—	—	—
	1¼	S4A	—	740	—	—	—	—	790	950	880	1050	—	—
		S5A SV2	490	700	20	16	28	21	—	—	—	—	—	—
	1½	S4A	830	1200	—	—	47	36	1300	1500	1400	1700	—	—
		S5A	960	1400	38	31	54	41	—	—	—	—	—	—
	2	S4A	1400	2000	—	—	78	60	2100	2500	2300	2800	—	—
		S5A	1300	1900	53	42	75	57	—	—	—	—	—	—
	2½	S4A	2000	2800	—	—	110	84	3000	3600	3300	3900	—	—
S5A		2100	3000	85	68	120	92	—	—	—	—	—	—	
3	S4A	2600	3700	—	—	150	110	4000	4700	4400	5200	—	—	
	S5A	3000	4200	120	95	170	130	—	—	—	—	—	—	
4	S4A	3800	5400	Use CK-2 or S9A ^④		220	160	5800	6900	6400	7700	—	—	
5	S4W	—	—	Use CK-2 or S9W ^④		290	220	7900	9500	8800	10000	—	—	
6	S4W	—	—	Use CK-2 or S9W ^④		530	400	14000	17000	16000	19000	—	—	
8	S4W	—	—	Use CK-2 or S9W ^④		810	620	22000	26000	24000	29000	—	—	

All capacities are maximum for the conditions listed and have no reserve for excess loads.

- ① **Liquid capacities for R22** are based on 100°F Condensing and 40°F evaporator temperatures with no flashing through the valve for the pressure drops listed. For each 10°F liquid is below 100°F, INCREASE values by 5%. **R717 capacities** are based on 20°F liquid with no flashing, 5°F evaporator temperature and no liquid overfeed. For liquid overfeed, multiply evaporator tons by recirculating rate and size valve to the tons result. Use of 20°F liquid for capacities in this table is sufficiently accurate for most liquid overfeed systems. To convert to 86°F liquid, multiply values in the table by 0.9.
- ② **Suction capacities for R22** are based on 100°F liquid and 10°F superheat entering the valve at the pressure drops and evaporator temperatures listed. For each 10°F liquid is below 100°F, INCREASE values by 5%. **R717 capacities** are based on 86°F condensing temperature and the evaporator temperatures listed. See A4A suction capacities on page 11 for other pressure drops and for corrections for liquid overfeed and sub-cooled liquid.
- ③ **Hot gas heat reclaim capacities** are in terms of heat of condensation rejected at the condenser and are based on saturated inlet conditions at pressures equivalent to the condensing temperatures and for the pressure drops listed.
- ④ **CK-2 and S9A.** See page 22 for low pressure drop at temperatures below 20°F.
- ⑤ **The 20mm port size S4A** is available with capacities equal to 50% of the ratings shown.



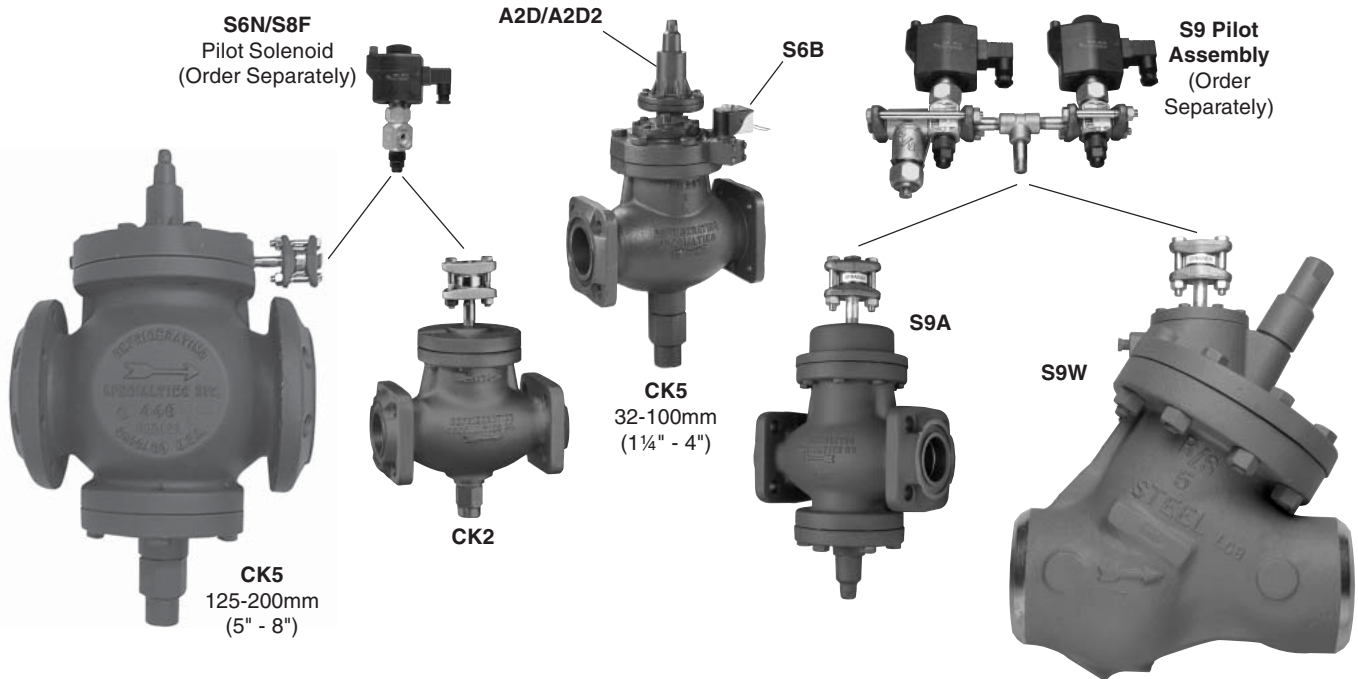

The CK5 is a uniquely constructed gas powered suction stop valve which operates in a similar manner to the R/S Type CK2. It is a normally open valve that uses discharge pressure to close.

Unlike the CK2, the CK5 is designed to remain in a closed position in the event that power to the pilot solenoid is inadvertently interrupted (i.e. a power failure), during hot gas defrost. This prevents a "suction shock" condition under these circumstances. Please see the latest revision of Bulletin 50-23.

Common Specifications

Max. Opening Pressure Difference ... 20.7 bar (300 psig)
 Design Pressure (MRP) 27.6 Bar (400 psig)
 Maximum Fluid Temperature 105°C (220°F)
 Coil Insulation Molded Waterproof Class B
 Standard Coil Housing NEMA 3R and 4

- Low pressure drop construction
- Ideal for overfeed or flooded systems
- Use in vertical or horizontal line (S6N and S8F Pilot Solenoid Valves must be installed with stems in vertical position.)
- Pilot connection contains disc strainer between a pair of flanges
- Suitable to -50°C (-60°F)
- Main valve can lie on its side for minimum pressure drop with two-phase flow conditions
- Manual opening stem
- Condenser gas powered piston and heavy return spring on Type S9 overcome viscous oil conditions

Selection Guide

Refrigerant Application	Refrigerant Temperature Range	VALVE MOST RECOMMENDED – Listed by Port Size											
		15mm	20mm	25mm	32mm	40mm	50mm	65mm	75mm	100mm	125mm	150mm	200mm
		½"	¾"	1"	1¼"	1½"	2"	2½"	3"	4"	5"	6"	8"
Suction	Above -50°C (-60°F) Normally Open*	Use larger size →			CK2 CK5	CK2A CK5	CK2 CK5	CK2 CK5	CK2 CK5	CK2 CK5	CK2 CK5	CK2 CK5	— —
	Above -50°C (-60°F) Normally Closed	Use larger size → → → →					S9A	S9A	S9A	S9A	S9W	S9W	S9W

Recommendations assume no highly viscous oil, dirt, moisture or foreign substance in refrigerant; also no abnormal shock impact below -30°C (-25°F).

* Use CK2 only above -30°C (-25°F) if not powered by near oil free hot gas, such as in rotary screw compressor systems.

Specifications

Type		CK2	CK2	CK5	CK5	S9A	S9W
Port Size	mm	32	40-150	32	40-150	50-100	125-200
	inch	1¼"	1½" - 6"	1¼"	1½" - 6"	2" - 4"	5" - 8"
Seat Material		PTFE	Metal	PTFE	Metal	Metal	Metal
Body Material		Gray Iron	Gray Iron	Gray Iron	Gray Iron	Gray Iron	Cast Steel
Minimum Pressure Drop to Open Wide	bar	0	0	0	0	0	0
	psi	0	0	0	0	0	0
Minimum Fluid Temperature	°C	-50°	-50°	-50°	-50°	-50°	-50°
	°F	-60°	-60°	-60°	-60°	-60°	-60°
Operation		Normally Open	Normally Open	Normally Open	Normally Open	Normally Closed	Normally Closed
Bulletin for Reference		50-12	50-12	50-23	50-23	31-90	30-05

Selection Guide

Port Size		Type	Description	Flow Coefficient		Pilot Solenoid*	Available Connections			Net Weight			
				Kv	Cv		SW,WN,FPT	ODS	DIN WN	Less Strainer		With Strainer	
mm	Inch									kg	lbs	kg	lbs
32mm	1¼"	CK2	Normally Open	16.3	19.0	(1) S6N	1¼", 1½"	1¾", 1½", 2½"	32, 40	11.8	26	16.3	36
		CK5	Normally Open	16.3	19.0	(1) S6B							
40mm	1½"	CK2	Normally Open	31.7	37.0	(1) S6N	1½", 2"	1½", 2½", 2¾"	40, 50	22.2	49	26.8	59
		CK5	Normally Open	31.7	37.0	(1) S6B							
50mm	2"	S9A	Normally Closed	38.5	45.0	(2) S6N	1½", 2"	1½", 2½", 2¾"	40, 50	27.2	60	36.3	80
		CK2	Normally Open	43.7	51.0	(1) S6N							
		CK5	Normally Open	43.7	51.0	(1) S6B							
65mm	2½"	S9A	Normally Closed	55.6	65.0	(2) S6N	2½", 3" (No FPT)	2¾", 3½"	65, 75	35.4	78	44.5	98
		CK2	Normally Open	70.2	82.0	(1) S6N							
		CK5	Normally Open	70.2	82.0	(1) S6B							
75mm	3"	S9A	Normally Closed	85.6	100	(2) S6N	3" (No FPT)	3½", 3¾"	75	51.8	114	60.8	134
		CK2	Normally Open	103	120	(1) S6N							
		CK5	Normally Open	103	120	(1) S6B							
100mm	4"	S9A	Normally Closed	154	180	(2) S6N	4" (No FPT)	4½"	100	64.9	143	74.0	163
		CK2	Normally Open	171	200	(1) S6N							
		CK5	Normally Open	171	200	(1) S6B							
125mm	5"	S9W	Normally Closed	171	200	(2) S6N	Weld End Only			60	134	67	148
		CK2	Normally Open	244	285	(1) S8F	5" (No FPT)	N.A.	N.A.	119	262	123	272
		CK5	Normally Open	244	285	(1) S8F							
150mm	6"	S9W	Normally Closed	308	360	(2) S6N	Weld End Only			103	229	109	243
		CK2	Normally Open	342	400	(1) S8F	6" (No FPT)	N.A.	N.A.	18	396	184	406
		CK5	Normally Open	342	400	(1) S8F							
200mm	8"	S9W	Normally Closed	471	550	(2) S6N	Weld End Only			168	372	174	386

* **S9 and CK2** gas powered valves are furnished standard without a pilot solenoid. If required, specify "with pilot solenoid" and give volts and frequency. The S6B solenoid pilot is included with **CK5 sizes 32-100mm**; the S8F pilot solenoid for **CK5 sizes 125-150mm** must be ordered separately. The **S9** Series uses a pilot assembly consisting of two solenoid valves. Standard connection for pilot is 3/8" FPT; also available in SW, WN or ODS.

To Order:

Specify: Port size, type, flange size and style, pilot connection size and style, with or without pilot solenoid, pilot solenoid coil style, volts and frequency, and pilot solenoid connection size and style.

Examples: 3" CK2, 3" WN, less pilot solenoids, with 3/8" FPT pilot connections; 65mm S9A, 2½" WN, with 3/8" pilot connection and with pilot assembly, encapsulated coil with leads, 230V 50Hz, 3/8" WN connections.

To order Pilot only: Specify Pilot Solenoid only, then give port size and type of main valve, coil style, volts and frequency.

Voltages

Coils are available from stock with most standard voltages. See table on page 7 for coil voltages and pilot light availability.

CK2/CK5 (KW)

	Evap. Temp, °C Evap. Press, bar	Press Drop, bar	Port Size (mm)								
			32	40	50	65	75	100	125	150	
R22	-10°C 2.5	.035 .017	23 16	46 32	60 42	99 70	140 100	240 170	340 240	470 340	
	-20°C 1.4	.035 .017	19 13	39 27	53 39	80 60	120 88	200 140	290 200	400 280	
	-35°C① 0.3	.035 .017	15 10	39 20	39 27	63 46	95 67	160 110	220 160	310 220	
	-45°C① 1.40	.035 .017	12 8.4	23 16	32 22	3 39	74 53	130 88	180 130	250 180	
R717	-10°C 1.9	.035 .017	49 35	98 70	130 95	210 150	310 220	520 370	750 520	1050 740	
	-20°C 0.9	.035 .017	42 28	81 56	110 77	180 130	260 180	440 310	630 440	880 620	
	-35°C① 61mm Hg	.035 .017	31 21	60 42	81 56	130 91	190 130	320 220	460 320	640 450	
	-45°C① 350mm Hg	.035 .017	24 17	46 32	63 46	110 74	150 110	250 180	360 250	500 360	

Capacities are based on liquid temperatures equal to evaporator temperatures. For liquid overfeed systems, nominal 2:1 to 5:1 ratio, add 20% to the evaporator load and select a valve based on the increased load.

① The CK2 may be used at these temperatures if it is powered by nearly oil free hot gas (such as in rotary screw compressor systems). If the gas is not nearly oil free, use the CK2 only at temperatures above -30°C.

CK2/CK5 (Tons)

	Evap. Temp, °F Evap. Press, psi	Press Drop, psi	Port Size (inches)									
			1¼	1½	2	2½	3	4	5	6		
R22	+10°F 32.8	0.50 0.25	6.2 4.4	12 8.6	17 12	27 19	39 28	65 46	93 66	130 93		
	-10°F 16.5	0.50 0.25	5.2 3.7	10 7.2	14 9.9	23 16	33 23	55 39	78 56	110 78		
	-30°F① 4.9	0.50 0.25	4.3 3.0	8.3 5.9	11 8.2	18 13	27 19	45 32	64 46	90 64		
	-50°F① 6.1" Hg	0.50 0.25	3.4 2.4	6.6 4.7	9.1 6.4	15 10	21 15	36 25	51 36	71 50		
R717	+10°F 23.8	0.50 0.25	15 11	29 20	40 28	64 45	94 66	160 110	220 160	310 220		
	-10°F 9.0	0.50 0.25	12 8.5	23 16	32 23	51 36	75 53	130 89	180 130	250 180		
	-30°F① 1.6" Hg	0.50 0.25	9.3 6.6	18 13	25 18	40 29	59 42	98 70	140 99	200 140		
	-50°F① 14.3" Hg	0.50 0.25	7.0 5.0	14 9.8	19 14	30 22	45 32	74 53	110 76	150 110		

Capacities are based on liquid temperatures equal to evaporator temperatures. For liquid overfeed systems, nominal 2:1 to 5:1 ratio, add 20% to the evaporator load and select a valve based on the increased load.

① The CK2 may be used at these temperatures if it is powered by nearly oil free hot gas (such as in rotary screw compressor systems). If the gas is not nearly oil free, use the CK2 only at temperatures above -25°F.

S9A/S9W (KW)

	Evap. Temp, °C Evap. Press, bar	Press Drop, bar	Port Size (mm)							
			50	65	75	100	125	150	200	
R22	-10°C 1.2	.035 .017	54 38	78 55	120 85	210 150	240 170	430 300	660 460	
	-20°C 0.5	.035 .017	46 32	66 47	100 72	180 130	200 140	360 260	560 390	
	-35°C 155mmHg	.035 .017	35 25	51 36	78 55	140 99	160 110	280 200	430 300	
	-45°C 381mm Hg	.035 .017	28 20	41 29	63 44	110 80	120 89	220 160	340 240	
R717	-10°C 1.9	.035 .017	120 84	170 120	260 190	480 340	530 370	950 670	1460 1030	
	-20°C 0.9	.035 .017	99 70	140 100	220 160	400 280	440 310	800 560	1210 860	
	-35°C 61mm Hg	.035 .017	72 51	100 74	160 110	290 200	320 230	580 400	880 620	
	-45°C 350mm Hg	.035 .017	57 40	83 58	130 90	23 160	250 180	460 320	700 490	

Capacities are based on liquid temperatures equal to evaporator temperatures. For liquid overfeed systems, nominal 2:1 to 5:1 ratio, add 20% to the evaporator load and select a valve based on the increased load.

S9A/S9W (Tons)

	Evap. Temp, °F Evap. Press, bar	Press Drop, bar	Port Size (inches)							
			2	2½	3	4	5	6	8	
R22	+10°F 32.8	0.50 0.25	15 10	21 15	33 23	59 41	65 45	120 83	180 130	
	-10°F 16.5	0.50 0.25	12 8.5	18 13	28 20	50 35	55 38	99 69	150 110	
	-30°F 4.9	0.50 0.25	10 7.0	15 10	22 15	40 28	45 31	81 57	120 86	
	-50°F 6.1" Hg	0.50 0.25	8.0 5.7	11 7.8	18 13	32 22	35 24	64 45	97 68	
R717	+10°F 23.8	0.50 0.25	35 24	51 36	78 55	140 99	160 110	280 200	430 300	
	-10°F 9.0	0.50 0.25	28 20	41 29	63 44	110 79	130 89	230 160	340 240	
	-30°F 1.6" Hg	0.50 0.25	22 15	32 22	49 34	88 62	98 69	180 120	270 190	
	-50°F 14.3" Hg	0.50 0.25	17 12	24 17	37 26	67 47	74 52	130 93	200 140	

Capacities are based on liquid temperatures equal to evaporator temperatures. For liquid overfeed systems, nominal 2:1 to 5:1 ratio, add 20% to the evaporator load and select a valve based on the increased load.

KW

	Port Size (mm)	Valve Type	Liquid Leg	Gas Return for Evap. Temp.			
				-10°C	-20°C	-30°C	-40°C
				R22			
	32	CK2 CK5	3.2	3.5	3.0	2.5	2.1
	40	CK2 CK5	4.6	6.2	5.3	4.5	3.7
	50	CK2 CK5 S9A	8.9	13	12	9.8	8.0
	65	CK2 CK5 S9A	14	20	17	15	12
	75	CK2 CK5 S9A	24	36	31	26	21
	100	CK2 CK5 S9A	48	77	67	56	46
	125	CK2 CK5 S9W	76	130	120	91	75
	150	CK2 CK5 S9W	130	230	200	160	140
	200	S9W	200	350	330	250	210
R717							
	32	CK2 CK5	14	9.1	7.3	5.3	4.2
	40	CK2 CK5	21	14	11	8.4	6.3
	50	CK2 CK5 S9A	39	34	27	21	16
	65	CK2 CK5 S9A	63	56	42	34	26
	75	CK2 CK5 S9A	100	94	73	56	42
	100	CK2 CK5 S9A	210	200	160	120	94
	125	CK2 CK5 S9W	350	360	290	220	160
	150	CK2 CK5 S9W	560	590	460	360	270
	200	S9W	880	880	730	560	420

Tons

	Port Size (inch)	Valve Type	Liquid Leg	Gas Return for Evap. Temp.			
				20°F	0°F	-20°F	-40°F
				R22			
	1¼"	CK2 CK5	0.93	1.1	0.93	0.79	0.65
	1½"	CK2 CK5	1.3	2.0	1.7	1.4	1.2
	2"	CK2 CK5 S9A	2.5	3.8	3.2	2.7	2.2
	2½"	CK2 CK5 S9A	4.3	6.1	5.2	4.3	3.4
	3"	CK2 CK5 S9A	7.1	10	9.0	7.5	5.9
	4"	CK2 CK5 S9A	14	20	19	16	12
	5"	CK2 CK5 S9W	25 25 22	37	31	25	20
	6"	CK2 CK5 S9W	39	65	53	43	35
	8"	S9W	60	100	88	73	57
R717							
	1¼"	CK2 CK5	4	2.6	2.1	1.6	1.2
	1½"	CK2 CK5	6	4.0	3.2	2.4	1.8
	2"	CK2 CK5 S9A	11	9.7	7.7	5.9	4.5
	2½"	CK2 CK5 S9A	18	16	12	9.6	7.3
	3"	CK2 CK5 S9A	30	27	21	16	12
	4"	CK2 CK5 S9A	60	57	45	35	27
	5"	CK2 CK5 S9W	100	100	82	63	48
	6"	CK2 CK5 S9W	160	170	130	100	78
	8"	S9W	250	270	210	160	120

NOTE: Capacities are nominal and are based on accepted industry practice concerning surge drum height and evaporator geometry.



Type H Valve



Two Valves on Manifold

Features

- High capacity
- Excellent repeatability
- Unaffected by vibration
- Drain plug standard
- Stainless steel internal parts

Specifications

Design Pressure (MRP) 27.6 Bar (400 psig)
 Maximum Fluid Temperature 150°C (300°F)
 Body Cast iron
 Internal Parts All stainless steel
 Seat PTFE

Valve Data

Valve Type	SINGLE VALVE ONLY				MANIFOLD FOR TWO VALVES		
	Connections		Pressure Setting (psig)	Capacity		Connections	
	Companion Mounting Flange (Inlet)	Relief Valve Outlet FPT		Lbs. Per Min Air	SCFM Air	Manifold Inlet Bottom	Relief Valve Outlet
H2	½" Port Provides ¾" FPT	1" FPT	50	23	302	Type M2 Manifold Provides ¾" FPT	1" FPT
			75	32	422		
			100	41	541		
			125	50	661		
			150	60	780		
			175	69	899		
			200	78	1019		
			225	87	1138		
			250	96	1257		
			275	105	1377		
300	114	1496					
H3	¾" Port Provides 1" FPT	1¼" FPT	50	38	498	Type M3 Manifold Provides 1" FPT	1¼" FPT
			75	53	694		
			100	68	890		
			125	83	1087		
			150	98	1283		
			175	113	1479		
			200	128	1676		
			225	143	1872		
			250	158	2068		
			275	173	2265		
300	188	2461					
H4	1" Port Provides 1¼" FPT	1½" FPT	50	57	744	Type M4 Manifold Provides 1½" FPT	1½" FPT
			75	79	1037		
			100	101	1330		
			125	124	1624		
			150	146	1917		
			175	169	2211		
			200	191	2504		
			225	213	2798		
			250	236	3091		
			275	258	3385		
300	281	3678					
H5	1¼" Port Provides 1¼" FPT	2"	50	95	1242	Type M4 Manifold Provides 1½" FPT	2" FPT
			75	132	1732		
			100	170	2222		
			125	207	2712		
			150	244	3202		
			175	282	3692		
			200	319	4182		
			225	357	4672		
			250	394	5162		
			275	431	5653		
300	469	6143					

Application

Used with ammonia and halocarbon refrigerants in noncorrosive environments. Relief Valves protect each refrigeration system pressure vessel that can be isolated by valves. Municipal codes may govern selection and installation. They may be patterned after the ASME boiler and pressure vessel code and the ANSI/ASHRAE 15-2001 safety code for mechanical refrigeration. ANSI/ASHRAE 15-2001 is highly recommended if there is no compulsory code.

The Type H safety relief valve is intended to prevent the pressure of the vessel from rising more than 10% above:

- (1) the design working pressure (DWP) of the vessel or
- (2) the pressure setting of the relief device.

Whenever conditions permit, it is advisable to have the relief valve pressure setting at least 25% higher than the normal operating pressure for the system.

The relief valve pressure setting must not exceed the design working pressure of the vessel.

Selection Data

On positive displacement compressor systems, pressure limiting devices – such as high pressure cutouts – must stop the action of the pressure imposing element at no higher than 90% of the pressure setting of the pressure relief device.

On non-positive displacement compressors, pressure limiting devices – such as high pressure cutout – may be set at the design working pressure (DWP) of the high side, provided:

1. The low side is protected by properly sized pressure at the low side DWP and
2. There are not stop valves in the system that isolate the high side from the low side.

Discharge piping from relief devices must not exceed lengths specified in ANSI/ASHRAE 15-2001 with discharge to atmosphere. Refer to our safety relief valve sizing program to determine discharge piping requirements which comply with ASHRAE 15-2001

Per ANSI/ASHRAE 15-2001, the formula for determining the minimum required discharge capacity of a relief device for each pressure vessel where the vessel is valved off from the refrigerating systems is: **C = FDL**, where: C = capacity, lb/min air; F = a factor from the table below; D = outside diameter of the vessel in feet, and L = length of vessel in feet.

Refrigerant	Factor (F)
R-717	0.5
R-22	1.6
<i>Consult factory for other refrigerants.</i>	

To Order

Specify: Valve type, pressure setting, single valve or dual valves with manifold. If single valve, with or without mounting flange. Refer to Bulletin 70-01.

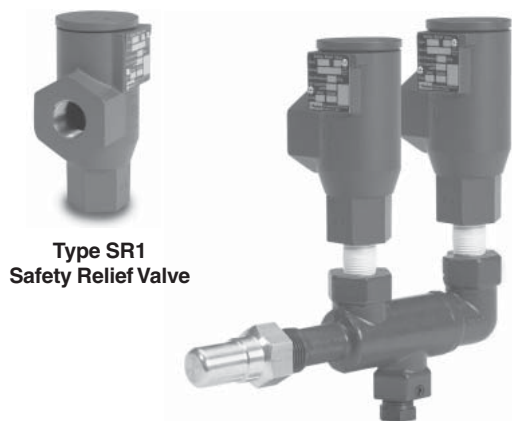

**Type SR1
 Safety Relief Valve**

**Type SR Valves
 on Type M1 Manifold**

- For use with R-22, R-717, R507 and other common refrigerants
- Designed to ASME VIII, ASHRAE and IIAR standards
- Pressure relief settings from 10.3 - 27.6 bar (150 - 400 psig)

Description

Parker Refrigerating Specialties has developed a family of low capacity safety relief valves to comply with the newly drafted ANSI/ASHRAE 15 safety code for mechanical refrigeration. The new low capacity **SR** safety relief valve meets the requirements for new installation and municipal ordinances. Precision machined moving parts of stainless steel and a PTFE disc prevent sticking due to corrosion or cold welding, to assure valve opening at the set pressure long after installation.

Connection sizes are 1/2" FPT inlet with 3/4" or 1" FPT outlet. A 3/4" FPT inlet with 1-1/4" or 1-1/2" FPT outlet is also available.

High capacity **SRH** Safety Relief Valves are designed and constructed to meet the requirements of ASME Boiler and Pressure Vessel Code and ANSI/ASHRAE 15-2001. They are designed to address the large installed population of safety relief valves, they are dimensionally a direct replacement for competing products. However valve capacity and piping must be checked to verify a proper selection.

Accessories

Rupture disc assemblies, pressure transducer, pressure switch and Teltale pressure gauge are available for the SR Series valves. Consult factory for details.

For more information, refer to Bulletin 71-00 (SR) or Bulletin 72-00 (SRH).

Manifold

Type M1 manifolds designed to ASME VIII, ASHRAE and IIAR standards are available for use with SR/SRH valves. See following page for dimensions.

- 1/2" inlet Part Number 107107
- 3/4" inlet Part Number 107108
- 1" inlet Part Number 107563
- 1 1/4" inlet Part Number 107564

Type SR Capacities

Size	Inlet FPT	Outlet FPT	Pressure Setting psig	Lbs. per Min Air	SCFM Air
SR1	1/2"	3/4"	150	10	130
			200	13	170
			250	16	210
			300	19	250
			350	22	290
400	25	329			
SR2	1/2"	1"	150	19	246
			200	25	321
			250	30	397
			300	36	472
			350	42	547
400	48	622			
SR3	3/4"	1 1/4"	150	29	377
			200	38	493
			250	46	608
			300	55	724
			350	64	839
400	73	955			
SR4	3/4"	1 1/2"	150	37	491
			200	49	641
			250	60	791
			300	72	945
			350	83	1091
400	94	1241			

Type SRH Capacities

Size	Inlet FPT	Outlet FPT	Pressure Setting psig	Lbs. per Min Air	SCFM Air
SRH1	1/2"	3/4"	150	35	463
			200	46	605
			250	57	747
			300	68	889
			350	79	1031
400	89	1173			
SRH2	1/2"	1"	150	35	463
			200	46	605
			250	57	747
			300	68	889
			350	79	1031
400	89	1173			
SRH3	3/4"	1"	150	35	463
			200	46	605
			250	57	747
			300	68	889
			350	79	1031
400	89	1173			
SRH4	1"	1 1/4"	150	61	798
			200	79	1042
			250	100	1311
			300	117	1530
			350	135	1775
SRH5	1 1/4"	1 1/2"	150	73	963
			200	96	1258
			250	118	1553
			300	141	1848
			350	163	2142

To Order

Specify: Model number, pressure setting.

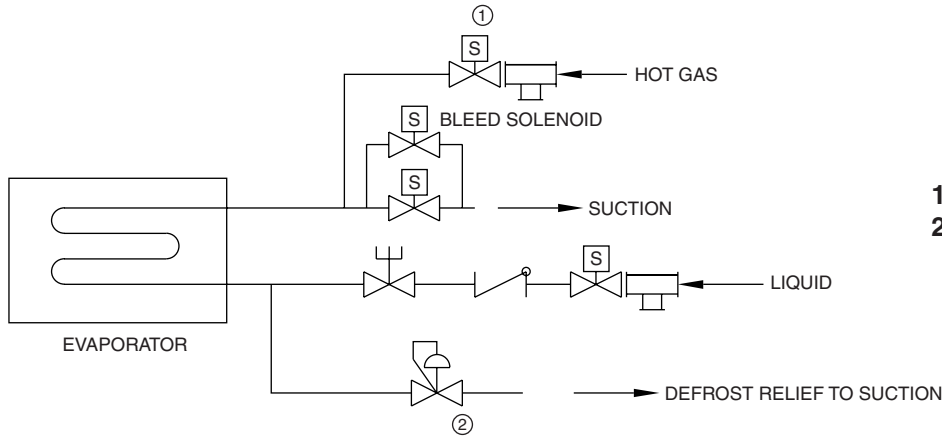

1. Hot Gas Supply Valve
2. Defrost Relief Valve

R22

Hot Gas Supply Valve Port Size & Valve Type ①	Defrost Relief Valve Port Size & Valve Type ②	Evap. Temp.				
		-10°C	-20°C	-30°C	-40°C	-50°C
13mm S8F, SV2 20mm 50% A4AOS	20mm 50% A4AK	16	13	11	9.5	8.3
20mm SV2, S4A, A4AOS	20mm A4AK	32	29	25	22	19
25mm SV2, S4A, A4AOS	25mm A4AK	41	36	35	33	27
32mm SV2, S4A, A4AOS	32mm A4AK	81	73	60	56	47
40mm S4A, A4AOS	40mm A4AK	200	160	140	120	97
50mm S4A, A4AOS	50mm A4AK	250	210	180	150	120

Notes

Nominal capacities listed are based on normal defrost times, saturated hot gas inlet to valve no less than 30°C, a 5°C difference between evaporator temperature and air entering evaporator, and an 8°C defrost temperature.

These capacities can be adjusted depending on the evaporator type and mass, the thickness of frost and other factors affecting the duration of the defrost process.

R717

Hot Gas Supply Valve Port Size & Valve Type ①	Defrost Relief Valve Port Size & Valve Type ②	Evap. Temp.				
		-10°C	-20°C	-30°C	-40°C	-50°C
13mm S8F, SV2 20mm 50% A4AOS	20mm 50% A4AK	41	33	28	24	19
20mm SV2, S4A, A4AOS	20mm A4AK	78	73	63	56	47
25mm SV2, S4A, A4AOS	25mm A4AK	110	89	91	85	72
32mm SV2, S4A, A4AOS	32mm A4AK	210	190	16	140	120
40mm S4A, A4AOS	40mm A4AK	500	430	390	320	260
50mm S4A, A4AOS	50mm A4AK	640	570	460	390	330

Equalizing the coil pressure after a defrost is critical to ensure that large suction valves do not open immediately and “shock” the system after the defrost has been terminated. This is especially true on large, low temperature coils, where the difference between the defrost pressure and the house suction is the greatest, and where the internal volume of the coil is largest. The addition of a vent solenoid (usually piped in parallel to the automatic suction valve), which opens for a pre-determined period after defrost (when the hot gas solenoid de-energizes, and the suction stop valve or suction solenoid remains closed), slowly bleeds down the coil pressure. This effectively allows the defrost to terminate in a “soft” and safe manner.

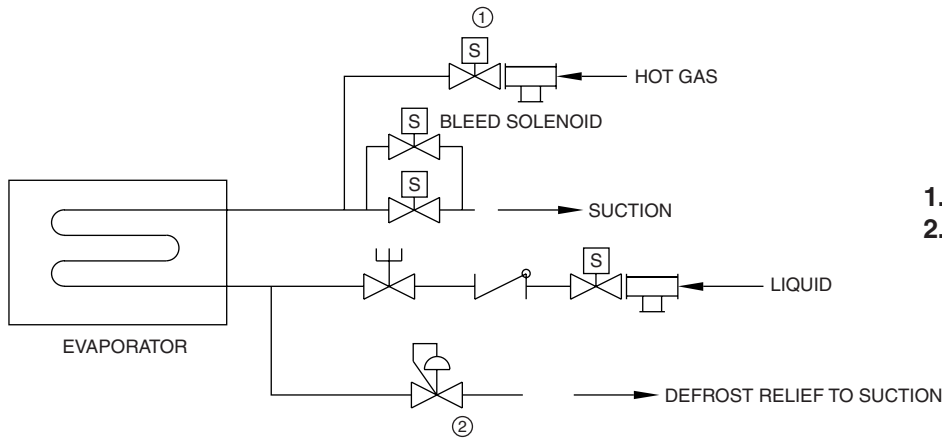

1. Hot Gas Supply Valve
2. Defrost Relief Valve

R22

Hot Gas Supply Valve Port Size & Valve Type ①	Defrost Relief Valve Port Size & Valve Type ②	Evap. Temp.				
		20°F	0°F	-20°F	-40°F	-60°F
½" S8F, SV2 ¾" 50% A4AOS	¾" 50% A4AK	5.5	4.1	3.2	2.7	2.3
¾" SV2, S4A, A4AOS	¾" A4AK	11	8.7	7.1	6.3	5.4
1" SV2, S4A, A4AOS	1" A4AK	14	11	10	9.3	7.6
1¼" SV2, S4A, A4AOS	1¼" A4AK	28	22	17	16	13
1½" S4A, A4AOS	1½" A4AK	66	47	40	33	27
2" S4A, A4AOS	2" A4AK	84	64	50	42	34

Notes

Nominal capacities listed are based on normal defrost times, saturated hot gas inlet to valve no less than 86°F, a 10°F difference between evaporator temperature and air entering evaporator, and an 47°F defrost temperature. These capacities can be adjusted depending on the evaporator type and mass, the thickness of frost and other factors affecting the duration of the defrost process.

R717

Hot Gas Supply Valve Port Size & Valve Type ①	Defrost Relief Valve Port Size & Valve Type ②	Evap. Temp.				
		20°F	0°F	-20°F	-40°F	-60°F
½" S8F, SV2 ¾" 50% A4AOS	¾" 50% A4AK	14	10	7.9	6.7	5.2
¾" SV2, S4A, A4AOS	¾" A4AK	27	22	18	16	13
1" SV2, S4A, A4AOS	1" A4AK	38	27	26	24	20
1¼" SV2, S4A, A4AOS	1¼" A4AK	72	56	45	40	34
1½" S4A, A4AOS	1½" A4AK	170	130	110	90	72
2" S4A, A4AOS	2" A4AK	220	170	130	110	91

Equalizing the coil pressure after a defrost is critical to ensure that large suction valves do not open immediately and "shock" the system after the defrost has been terminated. This is especially true on large, low temperature coils, where the difference between the defrost pressure and the house suction is the greatest, and where the internal volume of the coil is largest. The addition of a vent solenoid (usually piped in parallel to the automatic suction valve), which opens for a pre-determined period after defrost (when the hot gas solenoid de-energizes, and the suction stop valve or suction solenoid remains closed), slowly bleeds down the coil pressure. This effectively allows the defrost to terminate in a "soft" and safe manner.



Features

- Stainless steel seating.
- Spring tempered diaphragms.
- Bolt-on companion flanges

Description

Automatic expansion valve for all refrigerants also used as a small downstream pressure regulator. For additional information, refer to Bulletin 21-04.

Capacity in Tons

Model	Refrigerant	Condensing Temperature			
		110°F	100°F	90°F	80°F
190	R-717	23	21	19	17
	R-22	8	7	6.5	6
	R-12	5.5	5	4.5	4
	R-502	6.6	6	5.5	5
312	R-717	40	37	33	30
	R-22	14	12	11.5	10.5
	R-12	10	9	8	7
	R-502	12	10.8	9.6	8.5

Ordering Information

Specify: Type CFR, model number; companion flanges (1/4", 3/8", or 1/2" FPT); and pressure range:

- S = 2-90 PSIG,
- H = 75-300 PSIG,
- V = 25" vacuum-50 PSIG.

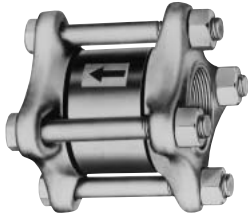

13-100mm
 (½" - 4")

CK4A

Flanged Inline Check Valve

- Light spring loaded
- Corrosion resistant, tapped metal seats
- Mounts in any position
- UL Listed (½" thru 3")



125-200mm
 (5" - 8")

CK1

Piston Type Check Valve

- Manual opening stem
- For horizontal use only



CK3

Piston Type Inline Check Valve

- Spring loaded
- PTFE seal
- Mounts in any position

Applications

Type	Port Sizes	Typical Applications	Mounting
CK4	13-200mm (½" - 8")	<ol style="list-style-type: none"> 1. Liquid lines 2. High speed compressor discharge lines (Not recommended for slow speed compressor discharge lines) 3. Pump discharge lines 4. Suction lines down to -55°C (-60°F) 5. Hot gas lines from pan to evaporator 6. Defrost relief regulator venting to an intermediate pressure 7. Prevent receiver pressure from backing up into a cold condenser 8. Prevent liquid returning to compressor during shutdown 9. Prevent liquid from flowing down into drain pan 10. Prevent reverse flow in suction line due to unusual load conditions 	Any position NOTE: Not recommended for side port applications on screw compressors
CK1	20-150mm (¾" - 6")	<ol style="list-style-type: none"> 1. Slow speed compressor discharge lines 2. Liquid lines 3. Suction lines down to -30°C (-25°F) 4. Side port applications on screw compressors 	Horizontal lines with opening stem in the vertical position
CK3	1/2 to 1 FPT	<ol style="list-style-type: none"> 1. Hot gas lines from pan to evaporator 2. Liquid lines 	Any position

Specifications

Type		CK4A	CK4A	CK4A	CK1	CK1	CK3
Port Size	mm	13	20-100	125-200	20-32	40-150	—
	inch	½"	¾" - 4"	5" - 8"	¾" - 1¼"	1½" - 6"	½ - 1 FPT
Seat Material		Stainless Steel	Stainless Steel	Stainless Steel	PTFE	Metal to Metal	PTFE
Body Material		Steel	Ductile Iron	Ductile Iron	Gray Iron	Gray Iron	Steel
Design Pressure (MRP)	bar	34.5	34.5	34.5	20.7	20.7	20.7
	psi	500	500	500	400	400	400
Fluid Temperature Limits	°C	-55° to 105°	-55° to 105°	-55° to 105°	-30° to 105°	-30° to 105°	-30° to 105°
	°F	-60° to 220°	-60° to 220°	-60° to 220°	-25° to 220°	-25° to 220°	-25° to 220°
Close Coupling to Valve*		Yes	Yes	No	Yes	Up to 100mm	No
Close Coupled Inlet Strainer		Yes	Yes	No	Yes	Up to 100mm	No
Minimum Pressure Drop to Open Wide	bar	0.05	0.05	0.05	0.03	0.03	0.34
	psi	0.75	0.75	0.75	0.5	0.5	5
Bulletin for Reference		50-16	50-16	50-20	50-10	50-10	50-13

*Close coupling using male adapter ring to outlet of R/S control valves.

Ordering Guide

Port Size		Type	Connections Available Standard Connection size in bold			Flow Coefficients		Net Weight	
mm	inch		FPT, SW, WN	ODS	DIN	Kv	Cv	kg	lb
13	1/2"	CK4A2	3/8", 1/2", 3/4"	1/2", 5/8", 7/8"	10, 15, 20	2.9	3.4	0.5	1
20	3/4"	CK4A3	3/4", 1", 1 1/4"	7/8", 1 1/8", 1 3/8"	20, 25, 32	6.1	7.1	2.3	2
25	1"	CK4A4	3/4", 1", 1 1/4"	7/8", 1 1/8", 1 3/8"	20, 25, 32	11	13	2.3	2
32	1 1/4"	CK4A6	1 1/4", 1 1/2"	1 3/8", 1 5/8", 2 1/8"	32, 40, 50	16	19	3.0	5
50	2"	CK4A8	1 1/2", 2"	2 1/8", 2 5/8"	40, 50	40	46	5.4	7
65	2 1/2"	CK4A9	2 1/2" (no FPT)	2 5/8", 3 1/8"	65, 75	60	70	10	12
75	3"	CK4A0	3" (no FPT)	3 1/8", 3 5/8"	75	96	112	12	16
100	4"	CK4A16	4" (no FPT)	4 1/8"	100	180	210	24	34
125	5"	CK4A	5" (no FPT)	N.A.	N.A.	240	280	20	45
150	6"	CK4A	6" (no FPT)	N.A.	N.A.	389	455	28	62
200	8"	CK4A	8" (no FPT)	N.A.	N.A.	670	783	44	96

To Order

Specify: Port Size, Valve Type, Flange Size, Flange Style and if with Strainer.

Example: 1" CK4A, 1" FPT

Standard connection styles:

FPT — 13-50mm (1/2" - 2") tongue and groove

SW — 65-100mm (2 1/2" - 4") tongue and groove; 125-200mm (5" - 8") 300 lb. ANSI

WN — 65-100mm (2 1/2" - 4") tongue and groove; 125-200mm (5" - 8") 300 lb. ANSI

CK4 Capacities (KW)

	Port Size (mm)	Liquid Line ①		Hot Gas Discharge ②		Suction Line ③	Liquid Line ④ (m³/H)
		pressure drop		pressure drop			
		0.051 bar	0.21 bar	0.051 bar	0.21 bar		
R22	13	30	60	5.9	12	2.7	0.6
	20	63	120	12	25	5.3	1.3
	25	110	220	22	46	9.9	2.3
	32	160	330	33	67	14	3.4
	50	400	810	81	160	34	8.4
	65	600	1200	120	240	53	13
	75	1000	1900	190	390	84	21
	100	1800	3500	350	700	150	38
	125	—	—	490	980	210	—
	150	—	—	770	1500	340	—
200	—	—	1300	2700	600	—	
R717	13	190	390	18	35	8.4	0.8
	20	390	770	35	70	18	1.8
	25	700	1400	67	130	32	3.2
	32	1100	2100	99	200	46	4.5
	50	2600	5100	230	470	110	11
	65	3900	7800	350	700	170	17
	75	6200	13000	560	1100	280	27
	100	11000	22000	1100	2100	490	52
	125	—	—	1400	2900	700	—
	150	—	—	2300	4600	1100	—
200	—	—	8000	16000	1900	—	

① **Liquid Line Capacities – R22** is based on 45°C (110°F) liquid and -5°C (20°F) evaporator temperatures. For each 5°C (10°F) liquid is below 45°C (110°F), increase capacities by 5%. **R717** is based on -7°C (20°F) liquid and -18°C (0°F) evaporator temperatures. To correct for 30°C (86°F) liquid, multiply capacities by 0.9.

② **Hot Gas Discharge Capacities – R22** is based on 32°C (90°F) condensing and -5°C (20°F) evaporator temperatures. **R717** is based on 30°C (86°F) condensing and -20°C (0°F) evaporator temperatures. Use at other typical conditions normally requires no capacity correction.

③ **Suction Line Capacities – R22** is based on 45°C (110°F) liquid and -25°C (-15°F) evaporator temperatures and 0.051 bar (0.75 psi) pressure drop. **R717** is based on 32°C (90°F) liquid and -18°C (-10°F) evaporator temperatures and 0.051 bar (0.75 psi) pressure drop.

④ **Liquid Capacities – R22** is based on 45°C (110°F) liquid temperature and 0.051 bar (0.75 psi) pressure drop. **R717** is based on -7°C (20°F) liquid temperature and 0.51 bar (0.75 psi) pressure drop. Correction factors for temperatures between -40°C (-48°F) and 30°C (86°F) are negligible.

CK4 Capacities (Tons)

	Port Size (inch)	Liquid Line ①		Hot Gas Discharge ②		Suction Line ③	Liquid Line ④ (GPM)
		pressure drop		pressure drop			
		0.75 psi	3.0 psi	0.75 psi	3.0 psi		
R22	1/2	8.4	17	1.7	3.4	0.73	2.8
	3/4	18	35	3.5	7.0	1.5	5.8
	1	32	64	6.4	13	2.8	10
	1 1/4	47	94	9.4	19	4.1	15
	2	114	230	23	46	9.7	37
	2 1/2	170	350	34	68	15	57
	3	280	550	55	110	24	91
	4	500	990	100	200	43	170
	5	—	—	140	280	60	—
	6	—	—	220	440	97	—
8	—	—	380	780	170	—	
R717	1/2	54	110	5.0	10	2.4	3.7
	3/4	110	220	10	20	5.0	7.7
	1	200	440	19	38	9.2	14
	1 1/4	300	600	28	56	13	20
	2	730	1400	67	134	32	50
	2 1/2	1100	2200	100	200	49	76
	3	1800	3500	160	320	79	120
	4	3200	6300	300	600	140	230
	5	—	—	410	820	200	—
	6	—	—	660	2300	320	—
8	—	—	1300	4500	550	—	

CK1 Ordering Guide

Port Size		Connections Available Standard Connection size in bold			Flow Coefficients		Net Weight	
mm	inch	FPT, SW, WN	ODS	DIN	Kv	Cv	kg	lb
20	3/4"	3/4", 1", 1 1/4"	7/8", 1 1/8", 1 3/8"	20, 25, 32	6.1	7.1	2.3	2
25	1"	3/4", 1", 1 1/4"	7/8", 1 1/8", 1 3/8"	20, 25, 32	11	13	2.3	2
32	1 1/4"	1 1/4", 1 1/2"	1 3/8", 1 5/8", 2 1/8"	32, 40, 50	16	19	3.0	5
50	2"	1 1/2", 2"	2 1/8", 2 5/8"	40, 50	40	46	5.4	7
65	2 1/2"	2 1/2" (no FPT)	2 5/8", 3 1/8"	65, 75	60	70	10	12
75	3"	3" (no FPT)	3 1/8", 3 5/8"	75	96	112	12	16
100	4"	4" (no FPT)	4 1/8"	100	180	210	24	34
125	5"	5" (no FPT)	N.A.	N.A.	240	280	20	45
150	6"	6" (no FPT)	N.A.	N.A.	389	455	28	62

To Order

Specify: Port Size, Valve Type, Flange Size, Flange Style and if with Strainer.

Example: 3" CK-1, 3" WN

Standard connection styles:

FPT — 13-50mm (1/2" - 2")

SW — 65-100mm (2 1/2" - 4")

WN — 125-150mm (5" - 6")

CK1 Capacities (KW)

	Port Size (mm)	Liquid Line ① pressure drop		Hot Gas Discharge ② pressure drop		Liquid Line ③ (m ³ /H)
		0.051 bar	0.21 bar	0.051 bar	0.21 bar	
		R22	20	67	160	
	25	70	180	17	42	1.5
	32	140	330	32	77	2.9
	40	260	630	63	150	5.6
	50	350	880	88	210	7.7
	65	600	1400	140	340	12
	75	840	2100	200	490	18
	100	1400	3500	340	840	30
	125	—	—	490	1200	—
	150	—	—	670	1600	—
R717	20	420	1000	46	110	1.9
	25	460	1100	49	120	2.0
	32	840	2100	90	220	3.8
	40	1700	4100	180	420	7.4
	50	2300	5700	240	600	10
	65	3700	9200	390	950	16
	75	5500	13000	560	1400	24
	100	9100	22000	950	2300	4
	125	—	—	1300	3300	—
	150	—	—	1900	4600	—

CK1 Capacities (Tons)

	Port Size (inch)	Liquid Line ① pressure drop		Hot Gas Discharge ② pressure drop		Liquid Line ③ (GPM)
		0.5 psi	3.0 psi	0.5 psi	3.0 psi	
		R22	3/4	19	47	
	1	20	50	4.8	12	2.8
	1 1/4	39	95	9.2	22	5.4
	1 1/2	75	180	18	44	10.5
	2	100	250	25	60	14.5
	2 1/2	170	400	40	97	23.3
	3	240	600	58	140	34
	4	400	990	97	240	56
	5	—	—	140	340	—
	6	—	—	190	470	—
R717	3/4	120	300	13	31	4.1
	1	130	320	14	33	4.3
	1 1/4	240	600	26	63	8.2
	1 1/2	480	1200	50	120	15.9
	2	660	1600	69	170	22
	2 1/2	1100	2600	110	270	35
	3	1600	3800	160	400	52
	4	2600	6300	270	660	86
	5	—	—	380	940	—
	6	—	—	540	1300	—

① **Liquid Line Capacities** – R22 is based on 45°C (110°F) liquid and -5°C (20°F) evaporator temperatures. For each 5°C (10°F) liquid is below 45°C (110°F), increase capacities by 5%. R717 is based on -7°C (20°F) liquid and -18°C (0°F) evaporator temperatures. To correct for 30°C (86°F) liquid, multiply capacities by 0.9.

② **Hot Gas Discharge Capacities** – R22 is based on 32°C (90°F) condensing and -5°C (20°F) evaporator temperatures. R717 is based on 30°C (86°F) condensing and -20°C (0°F) evaporator temperatures. Use at other typical conditions normally requires no capacity correction.

③ **Liquid Capacities** – R22 is based on 45°C (110°F) liquid temperature and 0.051 bar (0.75 psi) pressure drop. R717 is based on -7°C (20°F) liquid temperature and 0.51 bar (0.75 psi) pressure drop. Correction factors for temperatures between -40°C (-48°F) and 30°C (86°F) are negligible.

Suction Line Capacities

CK1 suction line capacities are the same as the values for the CK2 valves at 0.035 bar (0.5 psi) pressure drop. Refer to the CK2 tables on page 22.

CK3 Ordering Guide

Connection Size	Flow Coefficients		Net Weight	
	Kv	Cv	kg	lbs
1/2" SE	8.1	9.5	0.9	2
3/4" SE	9.0	10.5	0.9	2
1" SE	9.8	11.5	0.9	2

To Order

Specify: Size and Valve Type.

Example: 3/4" CK3

All connections are female NPT.

Minimum pressure drop to open: 0.34 bar (5 psi)

Features

- ASTM 352 LCB Cast Steel Body (3/4" thru 8")
- Maximum Safe Working Pressure 400 PSIG
- Fluid Temperature Range: -50°F to +300°F
- Stainless Steel Stem
- Reliable Back Seating
- Complete Line of Bolted Bonnets
- 25% Carbon Filled PTFE Seat (3/4" thru 8")
- Available Connections:
 - Threaded End, 3/4" thru 1"
 - Socket Weld, 3/4" thru 4"
 - Butt Weld, 1-1/4" thru 8"
- Linear Flow "Y" Pattern Globe Body for Low Pressure Drop
- Handwheel and Seal Cap Interchangeable on Same Valve



Description

This complete line of all steel bodied valves with bolt-on bonnets are designed and built to maintain reliability both in their seating and back seating functions. This entire line is supplied with stainless steel stems and backseating capability. Corrosion resistant, high-grade stainless steel trim is available upon request. A unique carbon filled PTFE seat is standard throughout the line, lending durability to the seating surface. In addition a dual O-Ring stem packing design along with a stem packing seal is standard on all valves from 3/4" thru 8". This innovative design seals both the valve stem and bonnet bore with independent O-Rings, which are captured in a carbon PTFE carrier. The addition of the packing provides for backup sealing capability in the unlikely event of an O-Ring failure.

A packing nut design with either 1/4" or 5/16" flats provide a generous wrench engagement area, with little likelihood of "rounding" the flat. With the O-Ring cartridge used in all valve bonnets, there will typically be no need to loosen the packing nut when opening or closing a valve. In most cases, stem resistance will be negligible allowing the valve to be easily repositioned.

For additional information, refer to Bulletin 85-00.

Ordering Information

Specify: Stop/check valve, port size, connection type, body style and if with handwheel or seal cap.

Body and Connection Availability

Table shows body and connection styles available for each port size.

Port Size	FPT		Socket Weld			Butt Weld	
	Angle	Globe "T"	Angle	Globe "T"	Globe "Y"	Angle	Globe "Y"
3/4"	●	●	●	●			
1"	●	●	●	●			
1 1/4"			●	●	●	●	●
1 1/2"			●	●	●	●	●
2"			●	●	●	●	●
2 1/2"			●	●	●	●	●
3"			●		●	●	●
4"			●		●	●	●
5"						●	●
6"						●	●
8"						●	●

Weights

Port Size	Weight	
	kg	lb
3/4"	1.8	4.0
1"	1.8	4.0
1 1/4"	4.2	9.2
1 1/2"	4.5	10
2"	6	13.2
2 1/2"	9.5	21
3"	15	33
4"	22	47
5"	44	98
6"	60	132
8"	116	255

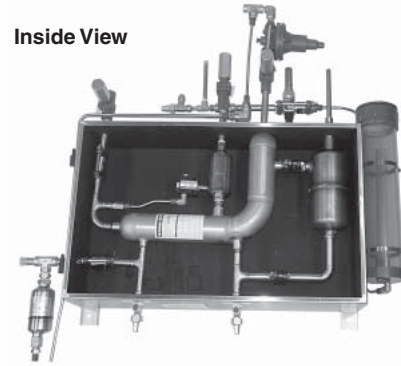
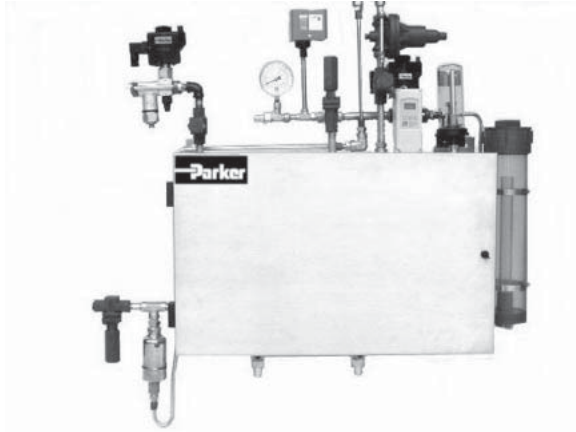

Features

- Stainless steel components
- Stainless steel cabinet
- Shell and tube heat exchanger (for maximum condensing surface area)
- Fixed orifice feed for high pressure liquid (No TXV)
- Float drainer installed on incoming foul gas line
- Programmable Microprocessor (optional) with up to 48 I/O for purge points
- "Mini" microprocessor (timer) available with 4 and 8 point purgers

The Refrigerating Specialties Rapid Purger safely and effectively removes non-condensable gases from an ammonia refrigeration system. By removing non-condensables, the refrigeration system is permitted to operate more efficiently and with less wear and tear on its components.

Basic Configurations

The Rapid Purger is available in two basic configurations, **Low Temperature** (-40°F to 20°F) and **High Temperature** (-10°F to 50°F). Both of these configurations are available for 120/60, 240/60 or 240/50 VAC applications

To Order, specify:

1. Type RP
2. Low temperature system (tied to suction pressures of up to 14 psi) or High temperature system (suction pressures of 15 psi or higher)
3. Number of purge points (4, 8, 16, 24 and 32 purge points available)
4. Processor (microprocessor recommended for 8 or more purge points; "mini" microprocessor programmable timer recommended for 2 or 4 purge points)

Controller Options

Both the Low and High Temperature Rapid Purgers may be ordered with or without a master electronic controller.

Manual Purger

Without an electronic controller, the Rapid Purger may be installed so that purge points are manually opened and closed. In addition, the basic Rapid Purger may be easily integrated into the customer's existing computerized central control system.

Features of a Rapid Purger without controller include:

- A high-efficiency heat exchanger with 2.6 square feet of condensing surface
- A stainless steel, air-tight, insulated enclosure
- Stainless steel components
- Unlimited number of purge points

Two types of master electronic controllers are available: the Mini Micro and the Full Microprocessor Controllers.

Mini Micro Controller

In addition to the basic features listed above, Rapid Purger with Mini Micro Controller includes:

- The ability to automatically and individually control up to eight purge points
- Resettable indicator to track the combined number of purges that foul gas is vented from the refrigeration system
- One, four, or eight purge points

Full Microprocessor Controller

With the Full Microprocessor, the Rapid Purger has:

- The ability to automatically and individually control up to 48 purge points
- A system status screen and keypad for system monitoring and set-point adjustments
- Password-restricted access
- Auto-detect capability to eliminate unnecessary purging
- NEMA 4 Electrical Enclosure
- Remote alarm option
- Optional condenser control
- Remote monitoring available through a 232 port
- Eight, 16, or 24 purge point configurations are readily available
- For 36 or 48 purge points, consult the factory

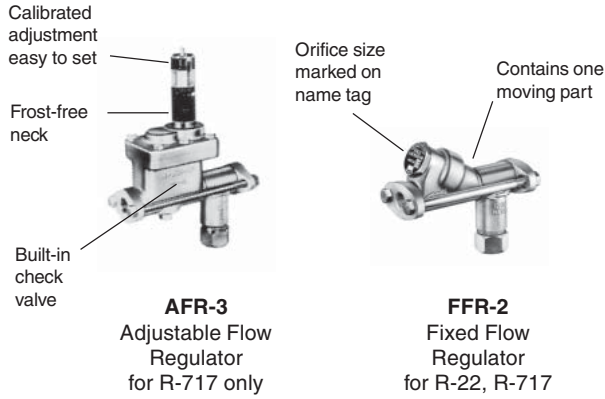

Features

- Eliminate surplus pumping cost
- Save balancing labor
- Permit evaporator optimization

Specifications

Body material Semi-steel
 Internal working parts Stainless steel
 Flange Size For R/S 13mm (1/2") port
 Design Pressure (MRP) 20.7 bar (300 psig)
 Minimum Fluid Temperature: -45°C (-50°F)

Application and Selection Guide

AFR-3

FUNCTION – To maintain a constant, *but adjustable flow rate and to act as a check valve*. Has flanged connections.

TYPICAL APPLICATION – Maintain constant flow rate of liquid to an evaporator on ammonia overfeed (recirculating) system. Also to serve as check valve during hot gas defrost. Not recommended if liquid is substantially warmer than the evaporator temperature.

AFR-3 Ordering Guide

Connections Available		Net Weight			
FPT, SW, WN	DIN WN	Without Strainer		With Strainer	
		kg	lbs	kg	lbs
1/2", 3/4"	10, 15, 20	3.6	8	4.5	10

3/4" FPT is standard and will be furnished unless specified otherwise.

To Order AFR-3

Specify: Type AFR-3, Flange Size, Flange Style and if with Strainer

Example: AFR-3, 3/4" SW, with Strainer

For more information, ask for Bulletin 41-10.

AFR-3 Capacities

(Not recommended for halocarbon refrigerants)

Note: R-717 liquid density correction is not necessary.

Field Scale Setting	Metric			U.S.		
	Equiv. KW	m ³ /hr	kg/min	Equiv. Tons	gpm	lb/min
5	17.5	0.065	0.8	5	0.3	1.7
10	34.9	0.14	1.6	10	0.6	3.4
20	69.9	0.27	3.1	20	1.2	6.8
30	105.0	0.41	4.7	30	1.8	10.2
40	140.0	0.54	6.3	40	2.4	13.6
50	175.0	0.68	7.9	50	3.0	17.0
60	210.0	0.82	9.5	60	3.6	20.4

FFR-2

FUNCTION – To maintain a constant, *non-adjustable flow rate. Has no check valve function*. Has flanged connections.

TYPICAL APPLICATION – Same as AFR-3 except not adjustable and not a check valve. Not recommended if liquid is substantially warmer than the evaporator temperature.

FFR-2 Ordering Guide

Orifice Number	Connections Available			Net Weight			
	FPT,SW,WN	ODS	DIN WN	Without Strainer		With Strainer	
				kg	lbs	kg	lbs
See Capacities Table	1/2", 3/4"	1/2", 5/8", 7/8"	10,15,20	3.6	8	4.5	10

To Order FFR-2

Specify: Type FFR-2, Orifice Number, Flange Size, Flange Style and if with Strainer. 3/4" FPT will be furnished unless otherwise specified.

Example: FFR-2-15, 3/4" WN, with Strainer

For more information, ask for Bulletin 41-15.

FFR-2 Capacities

For R-717. See notes below for other refrigerants.

With Orifice Number	Metric			U.S.		
	Equiv. KW	m ³ /hr	kg/min	Equiv. Tons	gpm	lb/min
4	14.0	0.055	0.6	4	0.24	1.4
6	21.0	0.085	1.0	6	0.36	2.0
10	34.9	0.14	1.6	10	0.6	3.4
15	52.4	0.20	2.3	15	0.9	4.1
20	69.9	0.27	3.1	20	1.2	6.8
30	105.0	0.41	4.7	30	1.8	10.2
40	140.0	0.54	6.3	40	2.4	13.6
60	210.0	0.82	9.5	60	3.6	20.4
80	279.0	1.1	12.6	80	4.8	27.2

NOTE: To convert FFR-2 capacities to R-22, multiply equivalent KW (tons) for R-717 by 0.23.

To select the proper FFR-2, multiply evaporator capacity by recirculation rate. Choose regulator with equal or slightly greater capacity. For example, for a 5-ton evaporator with a recirculation rate of 3, 5 (tons) x 3 = 15 (equivalent tons). Choose FFR-2 with orifice of 15.



Features

- Moving parts and switch hermetically sealed. Isolated from moisture, dust and tampering.
- Visual observation of switching action.
- Non mercury, 10 Amp snap-acting switch, fuse protected.
- Switch assembly can be replaced without opening to refrigerant pressure.
- Suitable for all common refrigerants and similar liquids
- Can be externally actuated with permanent magnet to check electrical circuits
- Switch assembly fully retatable to suit installation position
- Large available differential minimizes short cycling or actuation of switch by liquid surges
- UL listed

Type	Description	Net Weight	
		kg	lb
LL	Standard	4.5	10
LLA*	Low Temperature		
LLC	LL with Metal Cover	5.4	12
LLAC*	Low Temperature with Metal Cover		
LLS	Side, side and bottom connections	4.5	10
LLSC	LLS with Metal Cover	5.4	12

*Low Temperature models available to -75°C (-100°F), stainless steel.

Liquid Level Float Switch

Provides electrical switching action in response to a change in liquid level.

Applications

- To control liquid level in:
- Liquid over-feed accumulators
 - Flooded surge drums
 - Flooded shell and tube chillers
 - High and low pressure receivers
 - Intercoolers
 - Transfer vessels
 - Low or high level monitor

Specifications

Standard Chamber Material Steel
 Float Ball Material Stainless Steel
 Design Pressure (MRP) 300 psig (21 bar)
 Std. Fluid Temp. Range -45°C to 65°C (-50°F to 150°F)
 Ambient Temp. Range -45°C to 50°C (-50°F to 120°F)
 Switches SPDT, snap-acting, non-mercury
 Rating 120/240 VAC 10Amp 240 VA Pilot Duty
 Fluid Specific Gravity Range 0.57 to 1.70
 Differential Adjustable 13-50mm (½" - 2")
 Factory set at 50mm (2")
 Chamber Connections Combination fitting
 ¾" FPT or 1" Butt Weld
 Replaceable Fuse Style Bag 7 Amp 240 VAC

To Order

Specify Type. If for other than common refrigerants or refrigeration oil, give type and temperature of liquid, specific gravity and pressure to be encountered.

Replacement Switch Assembly: Part No. 050100

Permanent Magnet for external operation of switch:
 Part No. 201513

Sight Glass



The liquid level sight glass SG1 provides a clear indication of liquid levels in industrial refrigeration systems. The light intensity of the glass reflex lens provides a distinct indication of the presence of liquid (dark) or vapor (light).

Housing is made from ASME SA36 and meets material requirements of ASME for direct welding to vessels.

Features

- Reflex Lens
- Extended housing accommodates welding and insulation
- Optional Saddle Mill Housing
 Frost shield

Specifications

Design Pressure (MRP) 400 psig (27 bar)
 Fluid Temperature Range ... -50°C (-60°F) to 115°C (240°F)

To Order

Specify Type SG1 and length (2" or 4")

Automatic Liquid Drainer

The ALD Automatic Liquid Drainer permits flow of liquid refrigerant only. Prevents flow of vapor refrigerant. It is used to drain liquid from defrosting evaporators or heat recovery condensers into a lower pressure portion of the system.

The ALD is a combination of the components shown below with necessary pipe and fittings, complete for field assembly. See individual components for specifications.

For more information, refer to Bulletin 62-01.

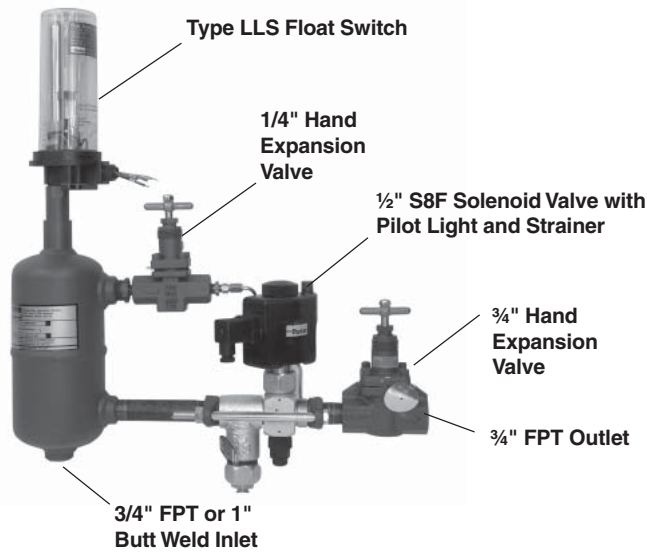

To Order

Furnished with a combination of 3/4" FPT or 1" butt weld inlet and 3/4" FPT outlet. 120, 208 or 240 volts, 60 Hertz; 115 or 230 volts, 50 Hertz available.

Specify: Type ALD, inlet, volts, frequency.

Example: Type ALD, 3/4" FPT, 208 volts, 60 Hertz.

Features

- For R717, R22 and other common refrigerants
- Drains liquid only
- Stops flow of vapor
- Prevents vapor lockup
- Built-in strainer
- No small orifices
- Resists wire drawing
- Includes pilot light
- Manual opening stem

Capacities

Metric (KW)

Hot Gas Defrost Liquid Drainer (Evaporator capacities at temperature listed)				
Evaporator Size (KW)				
Refrigerant	-7°C	-18°C	-29°C	
R22	48	39	34	
R717	120	100	87	
Heat Reclaim Condenser Liquid Drainer (Condenser flow rate at liquid temperatures listed)				
kg/min Flow Rate				
Refrigerant	38°C	24°C	10°C	-4°C
R22	24.7	26.3	26.8	27.3
R717	18.3	18.7	19.0	19.3

US (Tons)

Hot Gas Defrost Liquid Drainer (Evaporator capacities at temperature listed)				
Evaporator Size (Tons)				
Refrigerant	20°F	0°F	-20°F	
R22	14	11	10	
R717	35	29	25	
Heat Reclaim Condenser Liquid Drainer (Condenser flow rate at liquid temperatures listed)				
lb/min Flow Rate				
Refrigerant	100°F	75°F	50°F	25°F
R22	56.6	57.9	59.2	60.3
R717	40.4	41.2	41.8	42.5

Programmable Liquid Level Controller (PLL)



Features

- 5 Relays – Standard, Individually Fused (5 amp)
- 4-20mA Terminal Strip – Standard
- Compatible with any Length "Depth Tracker" Probe
- Two Test Modes – with Relays Energized and De-energized
- Supply Voltage – Auto Selecting
- No Calibration of Controller Required at Start-up

Applications

To control liquid levels in accumulators, flooded surge drums, flooded shell and tube chillers, high and low pressure receivers, intercoolers and transfer vessels.

Specifications

Power Required: 120/240V 60Hz or 110/220V 50Hz
 Controller Enclosure: NEMA 4
 Controller Ambient Temperature Range:
 +5° to +120°F (-15° to + 50°C)
 Relay Contact Rating: 10 Amp

Please refer to latest revision of Bulletin 61-50.

To Order

Specify Type PLLC.

Depth Tracker Probes

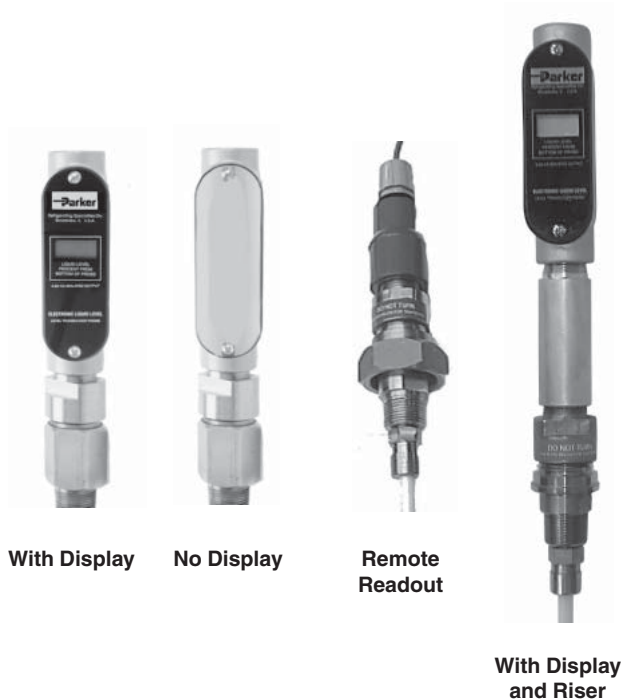

Features

- "Stand-Alone" probes with 4-20mA return signals or compatible with R/S Type PLLC Controller
- Available with or without digital readout
- Optional "Riser" accommodates column insulation
- Standard Probe lengths: 2, 3, 4, 5, 6, 7, 8, 10 & 12 feet
- Fully "potted" circuit board
- 3/4" Pipe thread connection
- Standpipe top cap available for 3" or 4" diameter column
- 12 to 36V DC power supply required (4-20mA return signal)
- Remote Readout – Maximum 6 foot cable (shielded)
- Water resistant construction

Applications

Liquid level transducer probe for ammonia refrigeration applications. The remote readout is typically used with long probes, to be positioned closer to eye level.

Please refer to latest revision of Bulletin 61-30.

To Order

Specify: DepthTracker, length, with or without digital readout, or remote readout. Also designate optional pipe cap and riser if required.

Flange Types

Flanges are sold individually and are available in male tongue type to fit sizes 5-150mm (½" to 6") and female groove type to fit sizes 5-100mm (½" to 4").

The following connection styles are available:

- Female Pipe Thread (FPT)
- Socket Weld (SW)
- Weld Neck (WN). Metric WN flanges also available in connection sizes ranging from 15 to 100mm. Consult factory for details.
- Outside Diameter Sweat (ODS) steel flanges with integral copper couplings to fit and solder over copper tubing. **ODS flanges are not suitable for use with R-717 (ammonia).**
- ANSI flat face flanges are available from 125-200mm (5" - 8") for use with the CK4 check valve.
- Slip-On Socket I.D. ANSI Flat Face
- Weld Neck ANSI Flat Face



2-Bolt Flanges (FPT, SW, WN, ODS)



4-Bolt Flanges (SW, WN, ODS)
 Also available in FPT

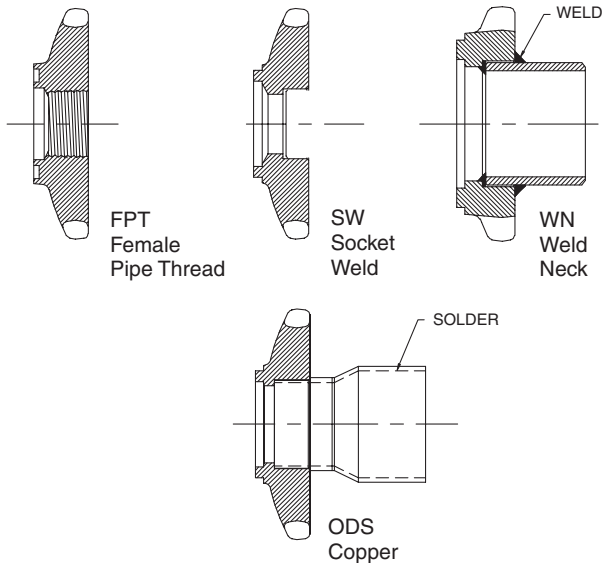

Flanges for sizes 5-25mm (3/16" to 1") are a 2-bolt oval style. Flanges for sizes 32-100mm (1¼" - 4") are a 4-bolt square style. Flanges for sizes 125-150mm (5" - 6") are an 8-bolt round style and are available as male type only.

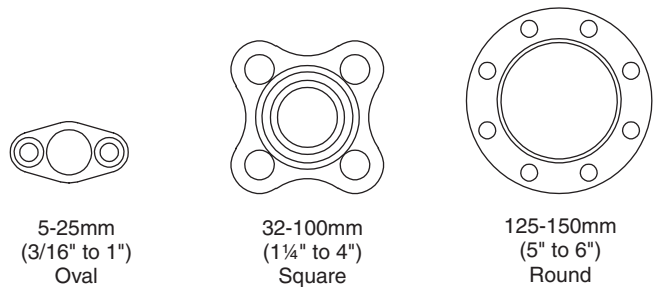

Flange Union Kits

Flange union kits are available to join male and female flanges of the same size (see page 89).

Flange and Pipe Dimensions

Nominal Inch	US Pipe Sizes		Equivalent Metric Steel Tubing		Socket Weld Flange I.D.		Weld Neck Flange O.D.		ANSI Slip-On Socket I.D.		ANSI Weld Neck Neck O.D.	
	Actual O.D. mm	Actual O.D. inch	NW	OD mm	mm	Inch	mm	inch	mm	inch	mm	inch
1/4"	13.72	0.540	8	13.5	14.22	0.560	13.72	0.540	—	—	—	—
3/8"	17.14	0.675	10	17.2	17.65	0.695	17.14	0.675	—	—	—	—
1/2"	21.34	0.840	15	21.3	21.84	0.860	21.34	0.840	—	—	—	—
3/4"	26.67	1.050	20	26.9	27.81	1.090	26.67	1.050	—	—	—	—
1"	33.40	1.315	25	33.7	34.67	1.365	33.40	1.315	—	—	—	—
1¼"	42.16	1.660	32	42.4	43.31	1.705	42.16	1.660	—	—	—	—
1½"	48.26	1.900	50	48.3	59.02	1.930	48.25	1.900	—	—	—	—
2"	60.32	2.375	50	60.3	62.10	2.445	60.3	2.375	—	—	—	—
2½"	73.02	2.875	65	76.1	74.80	2.945	73.03	2.875	—	—	—	—
3"	88.90	3.500	80	88.9	90.81	3.575	88.90	3.500	—	—	—	—
4"	114.30	4.500	100	114.3	116.20	4.575	114.30	4.500	—	—	—	—
5"	141.30	5.563	125	139.7	144.00	5.670	141.30	5.563	144.14	5.675	141.30	5.563
6"	168.28	6.625	150	165.1	170.90	6.730	168.28	6.625	171.07	6.735	168.28	6.625
8"	—	—	—	—	—	—	—	—	221.87	8.735	219.08	8.625

Connection Size Availability

Flange Size	Connection Sizes Available					
	FPT (IPS)	Socket Weld (IPS) Weld Neck (IPS)	ODS (US)	DIN Weld Neck (mm)	ANSI Flat Face**	
					Weld Neck	Slip-on
013	¼", ⅜", ½", ¾"	¼", ⅜", ½", ¾"	½", ⅝", ⅞"	10, 15, 20		
025	¾", 1", 1¼"	¾", 1", 1¼"	⅞", 1⅛", 1⅜"	20, 25, 32		
032	1¼", 1½"	1¼", 1½"	1⅜", 1⅝", 2⅛"	32, 40, 50		
050	1½", 2"	1½", 2"	1⅝", 2⅞", 2⅝"	40, 50		
065		2½"	2⅝", 3⅛"	65, 75		
075		3"	3⅛", 3⅝"	75		
100		4"	4⅞"	100		
125*		5"			5"	5"
150*		6"			6"	6"
200*					8"	8"

*Female flange not available

** For CK4 only

To Order:

Specify: Type FL, flange size, flange style and connection size.

Example: Type FL, 013 FPT with ½" connection.

Flanges are sold individually. Flange Union Kits sold below are used to join pairs of flanges.

Weights

Flange Number Size	Used on R/S Port Sizes		Net Weight for Each Flange							
			FPT, SW		WN		ODS		ANSI	
			mm	inch	kg	lbs	kg	lbs	kg	lbs
013	5 & 13	3/16" & 1/2"	0.14	0.3	0.23	0.5	0.14	0.3	—	—
025	20 & 25	3/4" & 1"	0.68	1.5	0.77	1.7	0.73	1.6	—	—
032	32	1-1/4"	0.68	1.5	0.91	2.0	0.73	1.6	—	—
050	40 & 50	1-5/8" & 1"	1.4	3.0	1.4	3.0	1.5	3.3	—	—
065	65	2-1/2"	2.3	5.0	3.0	6.5	2.5	5.5	—	—
075	75	3"	2.3	5.0	3.0	6.5	2.5	5.5	—	—
100	100	4"	4.1	9.0	6.8	15.0	4.5	9.9	—	—
125	125	5"	9.1	20.0	11.4	25.0	—	—	29.5	65
150	150	6"	9.1	20.0	11.4	25.0	—	—	38.6	85
200	200	8"	—	—	—	—	—	—	61.4	135

Flange Union Kits

Flange Union Kits are used to combine a male and a female flange within the same flange size code. Union Kits are available for flange sizes up to 100.

The kit consists of a flange gasket and the appropriate bolts for the flange size.

Order flanges separately.

Union Kits

Flange Size	Union Kit Part Number
013	206213
025	206214
032	206215
050	206216
065	206217
075	206218
100	206219

Adapter Rings

Adapter rings are furnished with two matching flange gaskets.

Male Adapter Rings

Are used to close couple CK-4A or CK-1 Check Valves to the outlet of R/S Control Valves.

To Order:

Specify MAR and flange size.

Example: MAR-25.

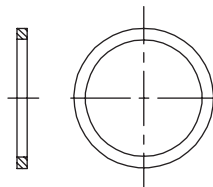

Female Adapter Rings

Are used in unions of two Male Flanges.

To Order:

Specify FAR and flange size.

Example: FAR-25.

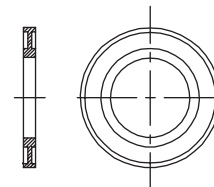

Globe and Angle Body Styles



**Globe "Y" Body,
 Butt Weld**



**Globe "T" Body,
 Socket Weld**



**Angle Body,
 Socket Weld**



**Hand Expansion Valve,
 Globe "T" Body, FPT**

Seal Caps
 (interchangeable with
 handwheels)



**Optional
 Extended Bonnet**

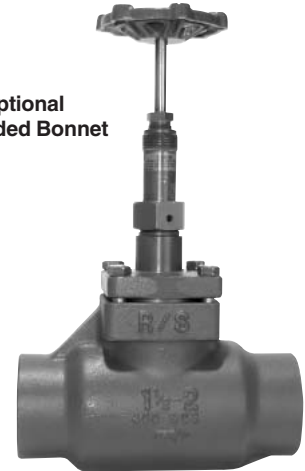

Hand Valves

- Threaded End (FPT): 6-38mm (¼" - 1½")
- Socket Weld: 6-100mm (¼" - 4")
- Butt Weld: 32-300mm (1¼" - 12")

Note: See chart on next page for complete hand valve and expansion valve availability.

Specifications

Body	Steel
Stem	Stainless Steel
Seat	25% Carbon filled PTFE
Packing	Carbon Graphite Composite
Max. Safe Working Pressure (MRP)	27.6 bar (400 psig)
Fluid Temp. Range	-50°C to 204°C (-60°F to 400°F)

Features

- All bolt on bonnets
- Suitable for Ammonia, R-22, nitrogen, carbon dioxide and other common refrigerants
- Reliable back seating
- Extended bonnets available for sizes up to 4" to accommodate thicker insulation for low temperature applications
- Stainless steel "trim" available for greater corrosion resistance
- Hand wheel and seal cap interchangeable on all hand shut-off valves for same price
- Hand expansion valves with "T" handle available up to 2" for socket weld, 1½" for threaded (FPT).
- "T" body and "Y" body styles available on selected globe valve sizes and types.
- Reliable dual o-ring seal along with a bonnet packing gland.

Body and Connection Availability

Table shows body and connection styles available for each port size hand shut-off valve.

Hand expansion valves are not available in sizes within the shaded area.

Port Size	FPT		Socket Weld			Butt Weld		
	Angle	Globe "T"	Angle	Globe "T"	Globe "Y"	Angle	Globe "T"	Globe "Y"
1/4"	M, S	M, S	M, S	M, S				
3/8"	M, S	M, S	M, S	M, S				
1/2"	M, S, ES	M, S, ES	M, S, ES	M, S, ES				
3/4"	M, S, ES	M, S, ES	M, S, ES	M, S, ES				
1"	M, S, ES	M, S, ES	M, S, ES	M, S, ES				
1¼"	M, S, ES	M, S, ES	M, S, ES	M, S, ES	M, S	M, S, ES		M, S
1½"	M, S, ES	M, S, ES	M, S, ES	M, S, ES	M, S	M, S, ES		M, S
2"			M, S, ES	M, S, ES	M, S	M, S, ES		M, S
2½"			M, S, ES	M, S, ES	M, S	M, S, ES		M, S
3"			M, S, ES		M, S	M, S, ES	M, S, ES	M, S
4"			M, S, ES		M, S	M, S, ES	M, S, ES	M, S
5"						M, S		M, S
6"						M, S		M, S
8"						M, S		M, S
10"						M, S		M, S
12"						M, S		M, S

LEGEND

M = Standard Bonnet with Mild Steel Trim
 S = Standard Bonnet with Stainless Steel Trim
 ES = Extended Bonnet with Stainless Steel Trim

To Order

Specify: Valve size, connection type, body type, handwheel or seal cap (hand shut-off only), and if with stainless steel trim or extended bonnet with stainless steel trim.

Examples:

2" socket weld angle body shut-off valve with handwheel.

1" FPT globe "T" hand expansion valve with extended bonnet .

Flow Coefficients and Weights

Valve Size		Flow Coefficients						Weights					
		Globe "T"		Globe "Y"		Angle		Globe "T"		Globe "Y"		Angle	
mm	inches	Kv	Cv	Kv	Cv	Kv	Cv	kg	lb	kg	lb	kg	lb
6	¼"	2.2	2.6	—	—	3.1	3.6	1	2.2	—	—	1	2.2
10	⅜"	3.5	4.1	—	—	4.7	5.5	1	2.2	—	—	1	2.2
13	½"	6.2	7.2	—	—	6.9	8.0	1.1	2.4	—	—	1.1	2.4
20	¾"	12	14	—	—	14.6	17	1.8	4.0	—	—	1.8	4.0
25	1"	18.9	22	—	—	23.2	27	1.8	4.0	—	—	1.8	4.0
32	1¼"	25.8	30	40.5	47	30.1	35	4.2	9.2	4.2	9.2	4.2	9.2
38	1½"	35	43	45.6	53	40	46	4.5	10	4.5	10	4.5	10
50	2"	52	61	80	92.6	73	85	6.5	14.4	6.5	14.4	6.5	14.4
65	2½"	89	103	131	153	128	149	9.5	21	9.5	21	9.5	21
75	3"	98	114	179	208	184	214	20	45	15	33	15	33
100	4"	173	202	292	340	301	350	34	74	22	47	18	40
125	5"	—	—	716	718	635	739	—	—	45	98	34	75
150	6"	—	—	788	916	811	943	—	—	80	132	45	99
200	8"	—	—	1244	1446	1280	1489	—	—	116	255	87	192
254	10"	—	—	2047	2380	2128	2475	—	—	190	417	142	313
305	12"	—	—	2820	3280	2941	3420	—	—	308	680	153	337



Features

- Handwheel or seal cap
- Replaceable PTFE seat disc
- Full-ported angular seat allows washing action
- Positive shut-off
- 50 & 100 mesh stainless steel screen
- Stainless steel stem with positive back seating
- Drain connection for safe cleaning
- Maximum Safe Working Pressure 400 PSIG
- Fluid Temperature Range -65°F to +350°F

Description

The Refrigerating Specialties combination stop/strainer shut-off valves are designed to provide all the benefits of a typical valve and strainer assembly within a single valve body. This unique combination valve decreases the effects of pressure drop in a system by eliminating the need for a separate strainer, while reducing system and installation costs.

Two-bolt body available with 1/2", 3/4" or 1" ports. Four-bolt body available in port sizes 1", 1 1/4", 1 1/2", 2", 2 1/2", 3" and 4".

The 1" two-bolt, 1-1/4" four-bolt and the 2" through 4" valves all use standard R/S Flanges.

The 1/2" and 3/4" two-bolt and 1" and 1-1/2" four-bolt valve do not use standard R/S Flanges.

The 1/2", 3/4" and 1" two-bolt valves cannot be close coupled.

For additional information, see Bulletin 86-00.

Ordering Information

Specify: Stop/strainer, port size, body type (for 1" sizes, specify 2- or 4-bolt body), hand wheel or seal cap, and if with flanges, flange size and type.



1/2"



1"



1 1/4" - 4"



5" - 8"
 Weld End

Application

Filter dirt particles from systems. Use for liquid, suction or hot gas. Can be close-coupled to inlet of any R/S valve with the same port size.

Specifications

Body Material 13-100mm (1/2" to 4") size Gray Iron

Body Material 125-200mm (5" to 8") size Cast Steel

Screen..... Stainless steel
 with openings 0.23 x 0.23mm (0.009" x 0.009")
 0.2mm (0.0075") wire (60 mesh)

Design Pressure (MRP) 27.6 bar (400 psig)

To Order

Specify Size and Type. If flanges are required, also specify with flanges, flange size and style.

Example: 2" Type RSF less flanges.

Type	Size	Used on Port Size		Flange Connections Available				Net Weight Less Flanges		Screen Area	
		mm	inch	FPT	SW, WN	ODS	DIN WN	kg	lbs	sq. cm	sq. in
RSF	13mm (1/2")	5 & 13	3/16" & 1/2"	3/8", 1/2", 3/4"	3/8", 1/2", 3/4"	1/2", 5/8", 7/8"	10, 15, 20	0.9	2	39	6
RSF	25mm (1")	20 & 25	3/4" & 1"	3/4", 1", 1 1/4"	3/4", 1", 1 1/4"	7/8", 1 1/8", 1 3/8"	20, 25, 32	3.2	7	116	18
RSF	32mm (1 1/4")	32	1 1/4"	1 1/4", 1 1/2"	1 1/4", 1 1/2"	1 3/8", 1 5/8", 2 1/8"	32, 40, 50	6.8	15	230	36
RSF	50mm (2")	40 & 50	1 5/8" & 2"	1 1/2", 2"	1 1/2", 2"	1 5/8", 2 1/8", 2 5/8"	40, 50	15	32	500	78
RSF	65mm (2 1/2")	65	2 1/2"	—	2 1/2"	2 5/8", 3 1/8"	65, 75	24	53	570	86
RSF	75mm (3")	75	3"	—	3"	3 1/8", 3 5/8"	75	24	53	570	86
RSF	100mm (4")	100	4"	—	4"	4 1/8"	100	52	114	794	123
RSW	125mm (5")	125	5"	5" Weld End only				45	100	790	123
RSW	150mm (6")	150	6"	6" Weld End only				79	175	1410	218
RSW	200mm (8")	200	8"	8" Weld End only				136	300	1750	272

Shipped without flanges unless specified otherwise. Strainers with flanges are shipped complete with one male and one female flange, bolts, nuts and gaskets. The 13mm (1/2") strainer is furnished with a 1/4" drain connection; 25-200mm (1"-8") strainers are furnished with 3/8" drain connection. Unless specified otherwise, 5-50mm (3/16"-2") strainers are furnished with standard FPT flanges, 65-100mm (2 1/2"-4") with SW flanges.

- ASTM Forged Steel Body
- Stainless Steel Stem
- Angle or Globe Body
- Extended length available on inlet
- 1/4" for regular gauge valves
- 3/8" for strainer bleed down valve

Description

This line of rugged all steel bodied tiny hand valves are designed to seat tight and permit isolation of small system components. The stainless steel stem has the safety feature of being non-removable. The angle bodied valve and the globe body employ the same features. The optional MPT or FPT inlet connection and variable extended lengths are provided on both body sizes.

These multiple use small hand valves are normally mounted to pipe line components and lead to a gauge or instrument line. Flow rate are not generally of consideration except where valve is employed as a drain device or on remote piloted control valves

The valve is manually closed to prevent venting or to permit downstream component servicing. When manually opened, the inlet pressure source is equalized to the downstream side. This supports draining, venting, purging or component isolation.

Materials

Body Forged steel, zinc plated
 Packing Nut Steel
 Stem Stainless steel, 1/4" square flats
 Stem Packing Graphite base
 Seal Cap Aluminum
 Seal Cap O-ring Neoprene

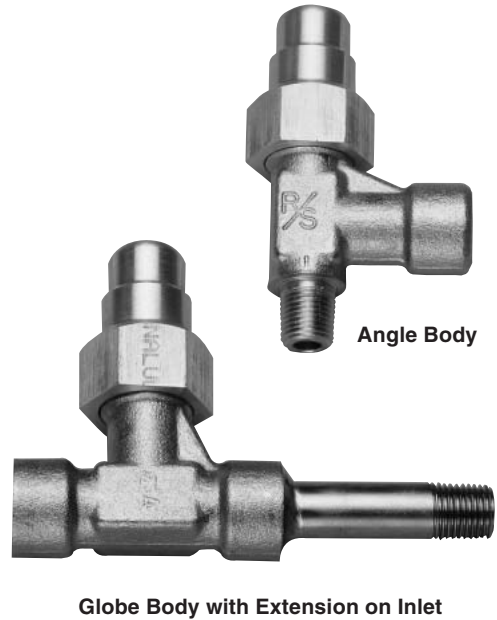

Specifications

Maximum Rated Pressure (MRP) 450 PSIG
 Fluid Temperature Range -40° to 115°C (-40° to 240°F)
 Gauge Port 1/4" FPT

Refer to Bulletin 84-00.

To Order:

To order, specify by part number from table below or by description (i.e., valve size, valve style, inlet connection and extension length).

Type V2

1/4" NPT with Plastic Seal Caps

Type	Inlet Connection	FPT Gauge Port Part Number	Ferulock Gauge Port Part Number
Angle	FPT	107014	—
	MPT	107015	107448
	2.50" Ext. MPT	107017	107450
	3.25" Ext. MPT	107018	107452
	3.75" Ext. MPT	107019	107454
	5.25" Ext. MPT	107020	107456
	6.50" Ext. MPT	107021	107458
	7.50" Ext. MPT	107022	107460
	8.50" Ext. MPT	107023	107462
Globe	FPT	107016	—
	2.50" Ext. MPT	107024	—
	3.25" Ext. MPT	107025	—
	3.75" Ext. MPT	107026	—
	5.25" Ext. MPT	107027	—
	6.50" Ext. MPT	107028	—
	7.50" Ext. MPT	107029	—
	8.50" Ext. MPT	107030	—

Type V3

3/8" NPT with Aluminum Seal Caps

Type	Inlet Connection	Part Number
Angle	FPT	106625
	MPT	106623
	3.25" Extended MPT	106628
	4.00" Extended MPT	106643
	5.00" Extended MPT	106644
	6.00" Extended MPT	106645
	7.00" Extended MPT	106646
	8.00" Extended MPT	106647
Globe	FPT	106626
	3.25" Extended MPT	106627
	4.00" Extended MPT	106648
	5.00" Extended MPT	106649
	6.00" Extended MPT	106650
	7.00" Extended MPT	106651
8.00" Extended MPT	106652	

- All gauges have adjustable pointer
- All gauges utilize stainless steel housing and polycarbonate window over face
- 2½" and 3½" gauges incorporate flutter prevention mechanism
- 2½" and 3½" gauges are ASME Grade B
 3%/2%/3% Max. Error
- 6" gauges are ASME Grade A 1% Max. Error



Description

All refrigerant gauges are combination pressure/saturation temperature gauges with pressure range appropriate to high side or low side duty for the refrigerants listed.

The 2½" and 3½" gauges are bottom connected 1/4" MPT. The 6" gauges are panel mount, back connected, 1/4" MPT.

To Order

Specify: Face diameter, refrigerant, metric or imperial units and high or low pressure range.

Materials

Socket and Bourdon:

- Gauges for Halocarbon Duty Bronze & Brass
- Gauges for Ammonia Duty Stainless Steel

Refrigerant	Pressure Ranges			
	Imperial Units (Temp in °F)		Metric Units (Temp in °C)	
	High Side Pressure Range	Low Side Pressure Range	High Side Pressure Range	Low Side Pressure Range
R717 (Ammonia)	30" Vac - 300 PSIG	30" Vac - 150 PSIG	760mm - 25 Bar	760mm - 10.5 Bar
R134a	30" Vac - 300 PSIG	30" Vac - 300 PSIG	760mm - 21.5 Bar	760mm - 21.5 Bar
R22	30" Vac - 500 PSIG	30" Vac - 150 PSIG	760mm - 35 Bar	760mm - 10.5 Bar
R-404A or R-507	30" Vac - 500 PSIG	30" Vac - 150 PSIG	760mm - 35 Bar	760mm - 10.5 Bar

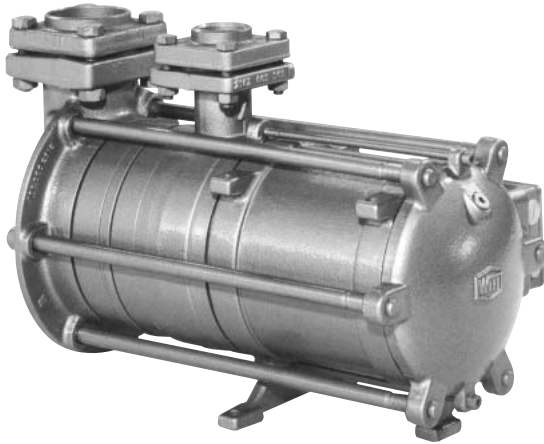

The HRP hermetically sealed pumps are intended to deliver liquid refrigerant (including ammonia, R22, and CO₂) to evaporators at saturated conditions. These pumps are not intended for intermittent duty, such as liquid transfer operation.

All of the HRP pumps may be mounted by either of two methods:

- Conventionally using the mounting feet, or
- Suspended by threaded rods to better accommodate normal, thermal pipe expansion/contraction as well as pump maintenance

Pump Capacity

The following table summarizes the operating capabilities of the HRP series pumps. For details of how to select a pump for a specific application, refer to the HRP Pump Service and Operation Manual, HRP-00.

MODEL	HP	Max Flow (GPM)	Max Head (FEET)
HRP-3232	1.3	23	145
HRP-5040	2.5	61	160
HRP-5050	5.4	72	230
HRP-8050	5.4	135	245
HRP-10080	11.4	285	213

Standard Pump Configuration

HRP series pumps are supplied standard with bolt-on inlet and discharge flanges that may be welded directly to the customer's existing piping.

Pump Connection Sizes

MODEL	Inlet Connection	Discharge Connection
HRP-3232	1-1/2"	1-1/2"
HRP-5040	1-1/2"	1-1/2"
HRP-5050	2"	2"
HRP-8050	2"	2"
HRP-10080	4"	3"

All pumps are protected with an internal conical strainer at the inlet connection. A flow sensor is also required to shut down the pump in low-flow or no-flow situations. In addition, each pump motor is protected with a thermal relay. A Turk Flow Switch with signal processor (part number 206960) is also available, which measures the GPM the pump generates and shuts the pump off should low flow conditions occur.

Available Options

The following items may be ordered separately to better integrate the pumps into the refrigeration system and to optimize pump performance and reliability.

- Low-pressure-drop inlet stop valve
- Low-pressure-drop discharge stop-check valve
- External inlet strainer
- Flow bypass valve
- Three-way valve with pressure gauge to monitor operation

Admissible Pressure Ranges

- 180 psi at -76°F to +14°F (12.5 bar at -60°C to -10°C)
- 362 psi at +14°F to +122°F (25 bar at -10°C to +50°C)
- Special pumps are available to accommodate pressures up to 580 psi (40 bar). Consult Refrigerating Specialties for further details.

Materials of Construction

- Pump housing GGG 40.3
- Stator Steel/Copper
- Rotor Steel/Aluminum
- Bearings PTFE
- Shaft 1 C 35
- Motor Can 1.4313 or 1.4059
- Impellers GX22CrNi17M

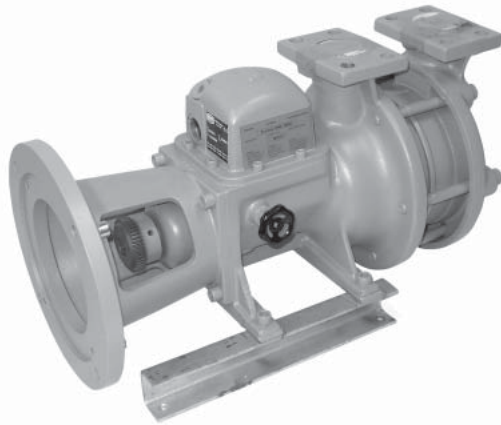

Type GP pumps are intended to deliver liquid refrigerant to evaporators at saturated conditions. These pumps can also be used to transfer liquid refrigerant between vessels. (Vessel pressures should be properly equalized.)

Pumps may be ordered either without motors (as replacements for existing systems), or with motors (for new applications).

Pump Capacity

The following table summarizes the operating capabilities of the HRP series pumps for ammonia and R22. For details of how to select a pump/motor combination for a specific application, refer to the GP Pump Service and Operation Manual, GP-00.

MODEL	R717 HP	R22 HP	Max Flow (GPM)	Max Head (Feet)
GP41 (1150 RPM)	0.75	1.0	11	50
GP42 (1150 RPM)	1.5	2.0	13	100
GP41 (1740 RPM)	1.5	3.0	18	115
GP42 (1740 RPM)	3.0	5.0	19	220
GP51A (1150 RPM)	3.0	5.0	32	70
GP51A (1740 RPM)	5.0	10	53	165
GP51 (1150 RPM)	3.0	5.0	58	60
GP52 (1150 RPM)	5.0	7.5	58	120
GP51 (1740 RPM)	7.5	10	86	140

Standard Pump Configuration

Whether ordered with or without a motor, GP series pumps are supplied with bolt-on inlet and discharge flanges that may be welded directly to the customer's existing piping. In addition, all pumps are protected with an internal conical strainer at the inlet connection.

Pump Connection Sizes

MODEL	Inlet Connection	Discharge Connection
GP-41	1-1/2"	1-1/2"
GP-42	1-1/2"	1-1/2"
GP-51	2"	2"
GP-51a	2"	2"
GP-52	2"	2"

Available Options

The following items may be ordered separately to better integrate the pumps into the refrigeration system and to optimize pump performance and reliability.

- Low-pressure-drop inlet stop valve
- Low-pressure-drop discharge stop-check valve
- External inlet strainer
- Differential pressure switch to shut down pump in low-flow conditions
- Flow bypass valve
- Three-way valve with pressure gauge to monitor operation

Admissible Pressure Ranges

- 116 psig at -76°F to +14°F (8 bar at -60°C to -10°C)
 For pump operation below -60°F, special low temperature oil must be ordered.
- 362 psig at +14°F to +122°F (25 bar at -10°C to +50°C)

Materials of Construction

Pump housing GGG 40.3
 Motor flange GGG 40
 Shaft 1 C 35
 Shaft seal PTFE
 Impellers GGG 40
 Reservoir oil MR 520

- Spring Return to Close
- RPTFE Stuffing Box Ring
- All Components of Lever are Stainless Steel
- Nitride Corrosion Protection
- Blow-out Proof Stem Design
- Adjustable Packing Gland
- Investment Cast Components
- Multifill Seats



Description

These carbon steel ball valves have a "deadman" spring return handle. Operating torque is approximately three times standard valve torque. Connections are threaded NPT.

Materials

Body A216-WCB
 "Deadman" Handle Stainless Steel
 Ball A108-CS Chrome Plated
 Stem Packing and Seat Multifill PTFE
 Body Seal PTFE
 Retainer, Gland Nut and Stem A108-CS

Specifications

WOG 138 bar (2000 psig)
 Cold Non-Shock 10.3 bar (150 psig) Saturated Steam,
 to 737mm (29 inches) Hg vacuum service
 Federal Specifications WW-V-35C, Type II

Ordering Information

Size	Part # Carbon Steel	Part # Stainless Steel	Weight
1/2"	206548	206551	0.6 kg (1.31 lb)
3/4"	206549	206552	0.9 kg (1.98 lb)
1"	206550	206553	1.1 kg (2.35 lb)

Spray Touch-up Paint

Same blue paint pigment to match Refrigerating Specialties Division's new factory enhanced, corrosion resistant paint.

- Meets Auto Industry Salt Spray Test Standards
- Water Based Low VOL
- EHS Compliant
- Quick Drying

Note: For overseas shipments, consult factory.



11 oz. Can **Order Part Number 309210**

Valve Classifications

Valve Classifications According to Pressure Equipment Directive 97/23/EC

PED compliant product can be ordered with standard flanges made from ASTM A105 forged steel.

Products in FLUID GROUP I, Category I, II, IV will carry CE mark and notified body number.

Products in FLUID GROUP II, Category I, will carry CE mark.

* Sound Engineering Practice

FLUID GROUP I (Ammonia)						
VALVE TYPE	SIZE	CATEGORIES				
		SEP*	I	II	III	IV
REGULATORS						
A2A	DN 15	✓				
A2B	DN 16	✓				
A2CK	DN 17					✓
A4A Adaptomode	DN 20 - 25	✓				
	DN 32		✓			
	DN 40 - 100			✓		
A4W	DN 125			✓		
SOLENOIDS						
SV2	DN 15 - 25	✓				
S6N	DN 15	✓				
S8F	DN 15	✓				
S7A	DN 20 - 25	✓				
S4A	DN 20 - 25	✓				
	DN 32		✓			
	DN 40 - 100			✓		
S5A	DN 32		✓			
	DN 40 - 75			✓		
S9W	DN125			✓		
STRAINERS	DN 15 - 25	✓				
	DN 32		✓			
	DN 40 - 125			✓		
CHECK VALVES						
CK4A INLINE	DN 15 - 25	✓				
	DN 32 - 100			✓		
CK1 PISTON-TYPE	DN 32		✓			
	DN 40 - 100			✓		
CK2 GAS POWERED	DN 32		✓			
	DN 40 - 100			✓		
CK5 GAS POWERED	DN 32		✓			
	DN 40 - 100			✓		
CK3 INLINE	DN 15 - 25	✓				
HAND VALVES						
DN 10 - 25		✓				
UNIBODY VALVES						
DN 5 - 10		✓				
GAUGES						
DN 7		✓				
FLOW REGULATORS						
AFR	DN 20	✓				
FFR	DN 20	✓				
RAPID PURGER						
LOW TEMP/HIGH TEMP	ASSEMBLY		✓			
LEVEL CONTROLS						
LL/LLC/LLS/LLA						✓
LIQUID DRAIN BALL VALVES						
DIN 15-25		✓				
FLUID GROUP II (Halocarbons)						
A9, A9E	DN 9 - 28	✓				
A8A/A8ABL	DN 9 - 22	✓				
A81/A81BL	DN 22 - 28	✓				
	DN 35		✓			
A82/A82BL	DN 42 - 66		✓			
(S)PORT/PORT	DN 9 - 28	✓				
	DN 35 - 66		✓			
(S)PORT/PORT B II	DN 9 - 26	✓				
	DN 35 - 66		✓			
S81	DN 22 - 28	✓				
	DN 35		✓			
S82	DN 42 - 66		✓			

General Information

Warranties

All Refrigerating Specialties products are warranted against defect in workmanship and materials for a period of one year from date of shipment from originating factory. This warranty is in force only when products are properly installed, field assembled, maintained and operated in use and service, as specifically stated in Refrigerating Specialties Catalogs or Bulletins for normal refrigeration applications, unless otherwise approved in writing by Refrigerating Specialties Division. Defective products, or parts thereof, returned to the factory with transportation charges prepaid, and found to be defective by factory inspection, will be replaced or repaired at Refrigerating Specialties option, free of charge, F.O.B. factory. Warranty does not cover products which have been altered, repaired in the field, damaged in transit or have suffered accidents, misuse or abuse. Products disabled by dirt or other foreign substances will not be considered defective.

THE EXPRESS WARRANTY SET FORTH ABOVE CONSTITUTES THE ONLY WARRANTY APPLICABLE TO REFRIGERATING SPECIALTIES PRODUCTS, AND IS IN LIEU OF ALL OTHER WARRANTIES, EXPRESSED OR IMPLIED, WRITTEN OR ORAL, INCLUDING ANY WARRANTY OF MERCHANTABILITY OR FITNESS FOR A PARTICULAR PURPOSE AND IN NO EVENT IS REFRIGERATING SPECIALTIES RESPONSIBLE FOR ANY CONSEQUENTIAL DAMAGES OF ANY NATURE WHATSOEVER. No employee, agent, dealer or other person is authorized to give any warranties on behalf of Refrigerating Specialties, nor to assume, for Refrigerating Specialties, any other liability in connection with any of its products.

For More Information

Consult our web site www.parker.com/refspec for the most current bulletins and catalog information on all our products.

Safe Operation

People doing any work on a refrigeration system must be qualified and completely familiar with the system and the Refrigerating Specialties Division valves involved, or all other precautions will be meaningless. This includes reading and understanding pertinent Refrigerating Specialties Division product bulletins and Bulletin RSB prior to installation or servicing work.

Where cold refrigerant liquid lines are used, it is necessary that certain precautions be taken to avoid damage which could result from liquid expansion. Temperature increase in a piping section full of solid liquid will cause high pressure due to the expanding liquid which can possibly rupture a gasket, pipe or valve. All hand valves isolating such sections should be marked, warning against accidental closing, and must not be closed until the liquid is removed. (Tags are available for this purpose from the factory.) Check valves must never be installed upstream of solenoid valves or regulators with electric shut-off, nor should hand valves upstream of solenoid valves or downstream of check valves be closed until the liquid has been removed. It is advisable to properly install relief devices in any section where liquid expansion could take place.

Avoid all piping or control arrangements which might produce thermal or pressure shock.

For the protection of people and products, all refrigerant must be removed from the section to be worked on before a valve strainer or other device is opened or removed.

Flanges with ODS connections are not suitable for ammonia service.

Factory Repair and Rebuilding

For the convenience of our customers, we have a standard factory repair and rebuilding service. Repairable returned regulators are disassembled, cleaned, sandblasted, worn parts replaced, reassembled and repainted. For quickest service, it is advisable that this be done during the off peak season.

Offer of Sale

The items described in this document are hereby offered for sale at prices to be established by Parker Hannifin Corporation, its subsidiaries and its authorized distributors. This offer and its acceptance by any customer ("Buyer") shall be governed by all of the following Terms and Conditions. Buyer's order for any item described in its document, when communicated to Parker Hannifin Corporation, its subsidiary or an authorized distributor ("Seller") verbally or in writing, shall constitute acceptance of this offer.

1. Term and Conditions of Sale: All descriptions, quotations, proposals, offers, acknowledgments, acceptances and sales of Seller's products are subject to and shall be governed exclusively by the terms and conditions stated herein. Buyer's acceptance of any offer to sell is limited to these terms and conditions. Any terms or conditions in addition to, or inconsistent with those stated herein, proposed by Buyer in any acceptance of an offer by Seller, are hereby objected to. No such additional, different or inconsistent terms and conditions shall become part of the contract between Buyer and Seller unless expressly accepted in writing by Seller. Seller's acceptance of any offer to purchase by Buyer is expressly conditional upon Buyer's assent to all the terms and conditions stated herein, including any terms in addition to, or inconsistent with those contained in Buyer's offer. Acceptance of Seller's products shall in all events constitute such assent.

2. PAYMENT-To approved accounts: Invoices dated 1 st to 15th, 1 % discount if paid by the 25th of same month; invoices dated 16th to the end of month, 1 % discount if paid by the 10th of next following month. All invoices shall be due net within 30 days after date of invoice. Any claims by Buyer for omissions or shortages in a shipment shall be waived unless Seller receives notice thereof within 30 days after Buyer's receipt of the shipment.

3. Delivery: Unless otherwise provided on the face hereof, delivery shall be made F.O.B. Seller's plant. Regardless of the method of delivery, however, risk of loss shall pass to Buyer upon Seller's delivery to a carrier. Any delivery dates shown are approximate only and Seller shall have no liability for any delays in delivery.

4. Warranty: Seller warrants that the items sold hereunder shall be free from defects in material or workmanship for a period of 365 days from the date of shipment to Buyer, or 2,000 hours of use, whichever expires first. THIS WARRANTY COMPRISES THE SOLE AND ENTIRE WARRANTY PERTAINING TO ITEMS PROVIDED HEREUNDER. SELLER MAKES NO OTHER WARRANTY, GUARANTEE, OR REPRESENTATION OF ANY KIND WHATSOEVER. ALL OTHER WARRANTIES, INCLUDING BUT NOT LIMITED TO, MERCHANTABILITY AND FITNESS FOR PURPOSE, WHETHER EXPRESS, IMPLIED, OR ARISING BY OPERATION OF LAW, TRADE USAGE, OR COURSE OF DEALING ARE HEREBY DISCLAIMED. NOTWITHSTANDING THE FOREGOING, THERE ARE NO WARRANTIES WHATSOEVER ON ITEMS BUILT OR ACQUIRED WHOLLY OR PARTIALLY, TO BUYER'S DESIGNS OR SPECIFICATIONS.

5. Limitation Of Remedy: SELLER'S LIABILITY ARISING FROM OR IN ANY WAY CONNECTED WITH THE ITEMS SOLD OR THIS CONTRACT SHALL BE LIMITED EXCLUSIVELY TO REPAIR OR REPLACEMENT OF THE ITEMS SOLD OR REFUND OF THE PURCHASE PRICE PAID BY BUYER, AT SELLER'S SOLE OPTION. IN NO EVENT SHALL SELLER BE LIABLE FOR ANY INCIDENTAL, CONSEQUENTIAL OR SPECIAL DAMAGES OF ANY KIND OR NATURE WHATSOEVER, INCLUDING BUT NOT LIMITED TO LOST PROFITS ARISING FROM OR IN ANY WAY CONNECTED WITH THIS AGREEMENT OR ITEMS SOLD HEREUNDER, WHETHER ALLEGED TO ARISE FROM BREACH OF CONTRACT, EXPRESS OR IMPLIED WARRANTY, OR IN TORT, INCLUDING WITHOUT LIMITATION, NEGLIGENCE, FAILURE TO WARN OR STRICT LIABILITY.

6. Changes, Reschedules and Cancellations: Buyer may request to modify the designs or specifications for the items sold hereunder as well as the quantities and delivery dates thereof, or may request to cancel all or part of this order, however, no such requested modification or cancellation shall become part of the contract between Buyer and Seller unless accepted by Seller in a written amendment to this Agreement. Acceptance of any such requested modification or cancellation shall be at Seller's discretion, and shall be upon such terms and conditions as Seller may require. Quantity increases, received after orders are acknowledged, will be priced separately as new orders. Quantity decreases, received after orders are acknowledged, will subject the order to repricing, if the decreases affect the original pricing guidelines.

7. Special Tooling: A tooling charge may be imposed for any special tooling, including without limitation, dies, fixtures, molds and patterns, acquired to manufacture items sold pursuant to this contract. Such special tooling shall be and remain Seller's property notwithstanding payment of any charges therefor by Buyer. In no event will Buyer acquire any interest in apparatus belonging to Seller which is utilized in the manufacture of the items sold hereunder, even if such apparatus has been specially converted or adapted for such manufacture and notwithstanding any charges paid by Buyer therefor. Unless otherwise agreed, Seller shall have the right to after, discard or otherwise dispose of any special tooling or other property in its sole discretion at any time.

8. Buyer's Property: Any designs, tools, patterns, materials, drawings, confidential information or equipment furnished by Buyer or any other items which become Buyer's property, may be considered obsolete and may be destroyed by Seller after two (2) consecutive years have elapsed without Buyer placing an order for the items which are manufactured using such property. Seller shall not be responsible for any loss or damage to such property while it is in Seller's possession or control.

9. Taxes: Unless otherwise indicated on the face hereof, all prices and charges are exclusive of excise, sales, use, property, occupational or like taxes which may be imposed by any taxing authority upon the manufacture, sale or delivery of the items sold hereunder. If any such taxes must be paid by Seller or if Seller is liable for the collection of such tax, the amount thereof shall be in addition to the amounts for the items sold. Buyer agrees to pay all such taxes or to reimburse Seller therefore upon receipt of its invoice. If Buyer claims exemption from any sales, use or other tax imposed by any taxing authority, Buyer shall save Seller harmless from and against any such tax, together with any interest or penalties thereon which may be assessed if the items are held to be taxable.

10. Indemnity For Infringement of Intellectual Property Rights: Seller shall have no liability for infringement of any patents, trademarks, copyrights, trade dress, trade secrets or similar rights except as provided in this Part 10. Seller will defend and indemnify Buyer against allegations of infringement of U.S. patents, U.S. trademarks, copyrights, trade dress and trade secrets (hereinafter "Intellectual Property Rights"). Seller will defend at its expense and will pay the cost of any settlement or damages awarded in an action brought against Buyer based on an allegation that an item sold pursuant to this contract infringes the Intellectual Property Rights of a third party. Seller's obligation to defend and indemnify Buyer is contingent on Buyer notifying Seller within ten (10) days after Buyer becomes aware of such allegations of infringement, and Seller having sole control over the defense of any allegations or actions including all negotiations for settlement or compromise. If an item sold hereunder is subject to a claim that it infringes the Intellectual Property Rights of a third party, Seller may, at its sole expense and option, procure for Buyer the right to continue using said item, replace or modify said item so as to make it noninfringing, or offer to accept return of said item and return the purchase price less a reasonable allowance for depreciation. Notwithstanding the foregoing, Seller shall have no liability for claims of infringement based on information provided by Buyer, or directed to items delivered hereunder for which the designs are specified in whole or part by Buyer, or infringements resulting from the modification, combination or use in a system of any item sold hereunder. The foregoing provisions of this Part 10 shall constitute Seller's sole and exclusive liability and Buyer's sole and exclusive remedy for infringement or Intellectual Property Rights.

If a claim is based on information provided by Buyer or if the design for an item delivered hereunder is specified in whole or in part by Buyer, Buyer shall defend and indemnify Seller for all costs, expenses or judgments resulting from any claim that such item infringes any patent, trademark, copyright, trade dress, trade secret or any similar right.

11. Force Majeure: Seller does not assume the risk of and shall not be liable for delay or failure to perform any of Seller's obligations by reason or circumstances beyond the reasonable control of Seller (hereinafter "Events of Force Majeure"). Events of Force Majeure shall include without limitation, accidents, acts of God, strikes or labor disputes, acts, laws, rules or regulations of any government or government agency, fires, floods, delays or failures in delivery of carriers or suppliers, shortages of materials and any other cause beyond Seller's control.

12. Entire Agreement/Governing Law: The terms and conditions set forth herein, together with any amendments, modifications and any different terms or conditions expressly accepted by Seller in writing, shall constitute the entire Agreement concerning the items sold, and there are no oral or other representations or agreements which pertain thereto. This agreement shall be governed in all respects by the law of the State of Ohio. No actions arising out of the sale of the items sold hereunder or this Agreement may be brought by either party more than two (2) years after the cause of action accrues.



C/ Montemayor, 2 Pta. 11 Der. 46950 Xirivella. Valencia (España) Tel. +34 963 799 829