

# Hot air blowers

R2K, RR

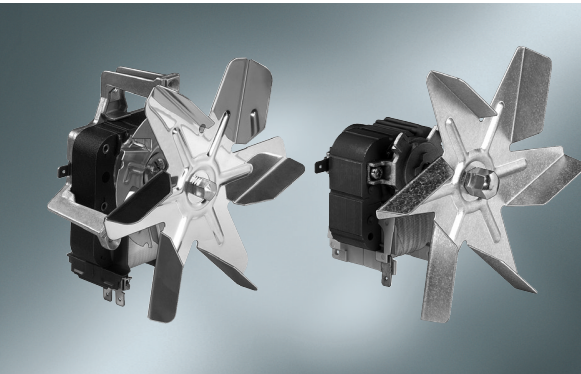

- bearing: R2K150 ball bearings „unit bearing“, integrated in rotor  
RR 152 sintered sleeve bearings with additional lubricant depot
- mounting position: R2K150 all mounting positions possible  
RR 152 horizontal shaft
- impeller: R2K150 stainless steel  
RR 152 FAL sheet steel
- mounting bracket: R2K150 three armed with triangular plate  
RR 152 bayonet type
- insulation class: H (EN 60335)

ebm-papst • Landshut

Nominal data	rated voltage	frequency	air flow	max. pressure increase	power input	speed	weight	recommended air intake	Dimensions mm		
	V	Hz	m³/h	Pa	W	min <sup>-1</sup>	kg	Ø	L1	L2	LG
<b>R2K150-AC</b>	230	50	200	155	32	2000	1	120	19	-	98,5
RR152-3025LH	230	50	190	150	37	2000	0,85	120	18,5	61	-

Technical data valid for typical applications; bold print = standard type; subject to alterations

## R2K150

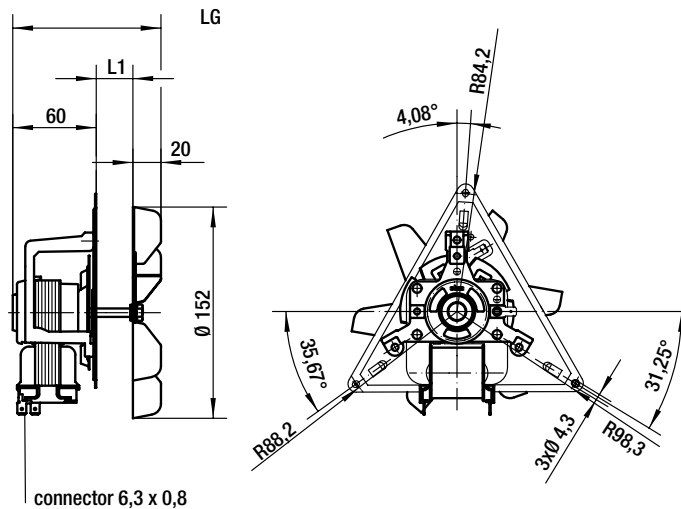

## RR152

