



2

Ejecución

Electrobombas centrífugas monobloc con acoplamiento directo motor-bomba y eje único. Cuerpo bomba con orificio de aspiración axial y orificio de impulsión vertical-radial, con dimensiones principales y prestaciones según EN 733 (UNI 7467).

Orificios: Bridas PN 10, EN 1092-2.

Contrabridas (bajo demanda)

Modelos	Bridas
de NM 32/... a NM 50/...	Bridas roscadas EN 1092-1, PN 16
de NM 65/... a NM 100/250	Bridas para soldar con aportación EN 1092-1, PN 10

Aplicaciones

- Para líquidos limpios sin partes abrasivas, y no agresivos para los materiales de la bomba (con partes sólidas hasta 0,2% máx).
- Para el aprovisionamiento de agua.
- Para instalaciones de calefacción, acondicionamiento, refrigeración y circulación. - Para aplicaciones civiles e industriales.
- Para instalaciones contra incendios. - Para irrigación.

Límites de empleo

Temperatura del líquido de -10 °C a +90 °C.
 Temperatura ambiente hasta 40 °C.
 Altura de aspiración manométrica hasta 7 metros.
 Presión final máxima admitida en el cuerpo de la bomba 10 bar.
 Servicio continuo.

Motor

Motor a inducción a 2 polos, 50 Hz (n = 2900 1/min).
NM: trifásico 230/400 V ± 10% hasta 3 kW.
 400/690 V ± 10% de 4 a 75 kW.

Aislamiento clase F.
 Protección IP 54.
 Ejecución según IEC 60034.

Otras ejecuciones bajo demanda

- Otras tensiones. - Frecuencia 60 Hz.
- Protección IP 55.
- Sello mecánico especial.
- Prensa estopos (solo para ejecución normal NM).
- Motor monofásico (NMM) hasta 1,5 kW.
- Ejecución monobloc antideflagrante según 94/9/CE (ATEX).
- Para líquidos o ambientes con temperaturas más elevadas o más bajas.

Materiales

Componentes	NM	B-NM
Cuerpo bomba	Hierro	Bronce
Acoplamiento	GJL 200 EN 1561	G-Cu Sn 10 EN 1982
Rodete	Hierro	Bronce
	GJL 200 EN 1561	G-Cu Sn 10 EN 1982
	Latón P- Cu Zn 40 Pb 2 UNI 5705 Para NM 32/12-16-20, NM 40/20 B-NM 32/125-160-200, B-NM 40/200	
Eje	Acero al Cr-Ni AISI 303 hasta 2,2 kW Acero al Cr AISI 430 de 3 kW a 75 kW	Acero al Cr-Ni-Mo AISI 316
Sello mecánico	Carbón - Cerámica - NBR	
Contrabridas	Acero Fe 430B UNI 7070	

Campo de aplicaciones n ≈ 2900 1/min

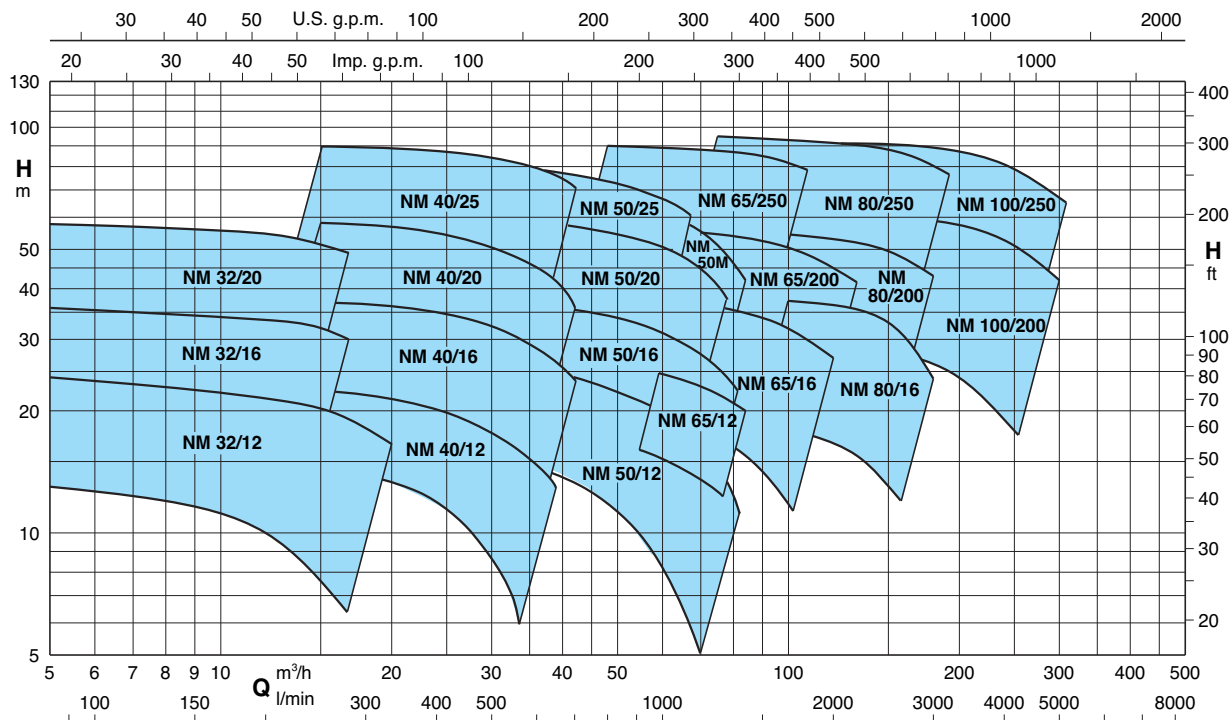

Prestaciones n ≈ 2900 1/min

B-NM	NM	P ₂		Q m ³ /h l/min	6,6	7,5	8,4	9,6	10,8	12	13,2	15	16,8	18,9	21	24	27	30
		kW	HP		110	125	140	160	180	200	220	250	280	315	350	400	450	500
					H m													
B-NM 32/125FE	NM 32/12FE	0,55	0,75		12,5	12,5	12	11,5	11	10	9	7,5						
B-NM 32/125DE	NM 32/12DE	0,75	1		18	18	17,5	17	16,5	16	15,5	14						
B-NM 32/125AE	NM 32/12AE	1,1	1,5		23	23	22,5	22	21,5	21	20,5	19						
B-NM 32/125SE	NM 32/12SE	1,5	2		23,5	23,5	23	22,5	22	21,5	21	20,5	19*	18,5*	16,5*	13*		
B-NM 32/160BE	NM 32/16BE	1,5	2		29,5	29,5	29	28,5	27,5	27	26	25*	22,5*					
B-NM 32/160AE	NM 32/16AE	2,2	3		35,5	35,5	35	34,5	34	33,5	33	32*	30*					
B-NM 32/200DE	NM 32/20DE	2,2	3		38	37,5	37	36	35	33,5	32							
B-NM 32/200CE	NM 32/20CE	3	4		45	44,5	44	43,5	42,5	41	40	38	36*					
B-NM 32/200AE	NM 32/20AE	4	5,5		57,5	57	56	55,5	55	54,5	53,5	51,5	49*					

B-NM	NM	P ₂		Q m ³ /h l/min	15	16,8	18,9	21	24	27	30	33	37,8	39	42	45	48	54
		kW	HP		250	280	315	350	400	450	500	550	630	650	700	850	800	900
					H m													
B-NM 40/125F/A	NM 40/12F/A	1,1	1,5		14	13,5	13	12	11	9,5	8	6						
B-NM 40/125C/A	NM 40/12C/A	1,5	2		17,5	17	16,5	16	15	13,5	12	10,5	7,5	6,5				
B-NM 40/125A/A	NM 40/12A/A	2,2	3		22	22	21,5	21	20	19	18	16,5	14	13	11,5			
B-NM 40/160C/A	NM 40/16C/A	2,2	3		23	22,5	22	21,5	20	18,5	16,5	14,5	11	10				
B-NM 40/160B/A	NM 40/16B/A	3	4		29	28,8	28	27,5	26,5	25	23,5	21,5	18	17	14			
B-NM 40/160A/A	NM 40/16A/A	4	5,5		37	36,5	36,5	36	35	33,5	32	30,5	27	26	23,5	20	17	
B-NM 40/200DE	NM 40/20DE	4	5,5		39	38	37	35,5	33,5	30,5	27	22,5	14					
B-NM 40/200CE	NM 40/20CE	4	5,5		41,5	40,5	39,5	38	36	33,5								
B-NM 40/200BE	NM 40/20BE	5,5	7,5		50	49,5	48,5	47,5	45,5	43,5	41,5	37,5	30,5					
	NM 40/20ARE	5,5	7,5		55	54,5	54	53	51	49								
B-NM 40/200AE	NM 40/20AE	7,5	10		57,5	57	56,5	55,5	54,5	52,5	50,5	48	42,5	40,5	35			
B-NM 4025/C/A	NM 40/25C/A	9,2	12,5		61	61	60,5	59,5	58,5	56,5	53,5	49,5	41,5	40	33,5			
B-NM 4025/B/A	NM 40/25B/A	11	15		69,5	69,5	69	68,5	67	65,5	63,5	60,5	53,5	51	45			
B-NM 4025/A/A	NM 40/25A/A	15	20		90	90	89,5	89	88,5	87	85	83	77,5	76	70,5			

B-NM	NM	P ₂		Q m ³ /h l/min	24	27	30	33	37,8	42	48	54	60	66	69	72	75	78	81	84
		kW	HP		400	450	500	550	630	700	800	900	1000	1100	1150	1200	1250	1300	1350	1400
					H m															
B-NM 50/125F/A	NM 50/12F/A	2,2	3				15,5	15	14	13,5	12	10	8	6						
B-NM 50/125D/A	NM 50/12D/A	3	4				20	19,5	18,5	18	16,5	14,5	13	10,5	9	8				
B-NM 50/125A/A	NM 50/12A/A	4	5,5				24	24	23	22,5	21	19,5	17,5	15	14	12,5	11,5	10		
B-NM 50/125S/A	NM 50/12S/A	4	5,5				26,5	26	25,5	24,5	23,5	22	20	18	16,5	15,5	14	13	11	
B-NM 50/160B/A	NM 50/16B/A	5,5	7,5				31	30,5	29,5	28	26	24	21,5	19	17,5	15,5	13,5	11,5	9,5	
B-NM 50/160A/A	NM 50/16A/A	7,5	10				38,5	38	37,5	36,5	34,5	32,5	30	27	25,5	24	22,5	20,5	19	
B-NM 50/200B/A	NM 50/20B/A	9,2	12,5		48	47,5	47,5	47	45,5	44,5	42,5	40	37	33	30,5	28	25,5	23		
B-NM 50/200A/A	NM 50/20A/A	11	15		55	55	54,5	54,5	53,5	52	50	48	45	41,5	39,5	37	35	32,5		
B-NM 50/200S/A	NM 50/20S/A	15	20		60	60	59,5	59,5	58,5	57,5	55,5	53,5	50,5	47	45	43	40,5	37		
B-NM 5025/C/A	NM 50/25C/A	11	15		55	54,5	54	53	51,5	49,5	46	41,5	35,5	28,5	24,5					
B-NM 5025/B/A	NM 50/25B/A	15	20		69	68,5	68	67,5	66	64	61	57	52,5	46,5	43					
B-NM 5025/A/A	NM 50/25A/A	18,5	25		80,5	80,5	80	79,5	78,5	77	74,5	71,5	67	61,5	58,5					
B-NM 5025/65EE	NM 50M/EE	11	15			48	47,5	47	46	45	43	40	37	32	29,5	27	24			
B-NM 5025/65DE	NM 50M/DE	15	20				57	56,5	56	55	53	51	48	44,5	42	39,5	37	32	29	25*
B-NM 5025/65CE	NM 50M/CE	18,5	25				68	67,5	67	66,5	65	63	61	58	56	53,5	51,5	48	45,5	42*

B-NM	NM	P ₂		Q m ³ /h l/min	37,8	42	48	54	60	66	75	84	96	108	120	132	150	168
		kW	HP		630	700	800	900	1000	1100	1250	1400	1600	1800	2000	2200	2500	2800
					H m													
	NM 65/12EE	4	5,5		18	17,5	17	16,5	16	15	13,5*							
B-NM 65/125CE	NM 65/12CE	5,5	7,5		22	21,5	21	20,5	20	19,5	18	15,5*						
B-NM 65/125AE	NM 65/12AE	7,5	10		26	25,5	25	24,5	24	23,5	22	20*						
B-NM 65/160EE	NM 65/16EE	5,5	7,5				20	19,5	19	18,5	17	15,5	13*	10*				
B-NM 65/160DE	NM 65/16DE	7,5	10				26	25,5	25	24,5	23,5	22	20*	16,5*	13*			
B-NM 65/160CE	NM 65/16CE	9,2	12,5				30	29,5	29	28,5	28	26,5	24,5*	21,5*	18*			
B-NM 65/160BE	NM 65/16BE	11	15				33,5	33	32,5	32	31	30	28*	25,5*	22*			
B-NM 65/160AE	NM 65/16AE	15	20				38	37,5	37	36,5	36	35	33*	30,5*	27*			
B-NM 65/200CE	NM 65/20CE	15	20				44	43,5	43	42,5	41	39,5	37,5*	35*	31*	27*		
B-NM 65/200BE	NM 65/20BE	18,5	25				50	49,5	49	48,5	47,5	46,5	44,5*	42*	39*	35*		
B-NM 65/200AE	NM 65/200AE	22	30				56,5	56	55,5	55	54,5	53,5	51*	48,5*	45,5*	41,5*		
B-NM 65/250CE	NM 65/250CE	22	30				64	63,5	63	61,5*	60*	57,5*	54,5*	50*				
B-NM 65/250BE	NM 65/250BE	30	40				79,5	79	78,5	78*	77*	75*	72*	67*				
B-NM 65/250AE	NM 65/250AE	37	50				90	89,5	89	88,5*	87,5*	86*	83,5*	78,5*				

Prestaciones n ≈ 2900 1/min

B-NM	NM	P ₂		Q m ³ /h l/min	H m																
		kW	HP		75	84	96	108	120	132	150	168	180	192	210	240	270	300			
B-NM 80/160EE	NM 80/16EE	7,5	10	20	19,3	18,5	17,5*	16,5*	15,5*	13*											
B-NM 80/160DE	NM 80/16DE	9,2	12,5	23	22,5	22	21*	19,5*	18*	15*											
B-NM 80/160CE	NM 80/16CE	11	15	27,5	27	26,5	25,5*	24,5*	23*	20*	16*										
B-NM 80/160BE	NM 80/16BE	15	20	34	33,5	33	32,5*	32*	31*	28*	23*	18*									
B-NM 80/160AE	NM 80/16AE	18,5	25	38,5	38	37,5	37*	36,5*	36*	33*	29*	24*									
	NM 80/200BE	22	30	46,5	46	45,5	44,5	43,5*	42*	39*	35,5*	32*									
	NM 80/200AE	30	40	56	55,5	55	54	53*	52*	49,5*	46*	43*									
	NM 80/250EE	22	30	51	50	48,5	46,5	44,5*	42*	38*	33*	29*									
	NM 80/250DE	30	40	65	64	62,5	61	59*	56,5*	53*	49*	45,5*	41*								
	NM 80/250CE	37	50	73,5	73	72	70,5	69*	67*	63*	59*	55,5*	51,5*								
	NM 80/250BE	45	60	84	83,5	82,5	81,5	80*	78*	74,5*	70,5*	67*	63*								
	NM 80/250AE	55	75	95	94,5	93,5	92,5	91,5*	90*	87,5*	84*	80,5*	76,5*								
	NM 100/200EE	18,5	25				30	29,5	29	28	27	26*	25*	23*	19*						
	NM 100/200DE	22	30				36	35,5	35	34	33	32*	31*	29*	24,5*	19*					
	NM 100/200CE	30	40				45	44,5	44	43,5	42,5	41,5*	40,5*	39*	34,5*	29*					
	NM 100/200BE	37	50				54	53,5	53	52,5	51,5	50,5*	49,5*	48*	44*	38,5*	32°				
	NM 100/200AE	45	60				61,5	61	60,5	60	59,5	58,5*	58*	56,5*	53*	48*	42°				
	NM 100/250BE	55	75				73,5	73	72,5	71,5	70	68,5*	67*	65*	61*	55,5*	48,5°				
	NM 100/250AE	75	100				91	90,5	90	89,5	88,5	88*	87*	85*	81*	75*	67°				

NM Ejecución normal.
B-NM Ejecución en bronce.

P₂ Potencia nominal del motor.
H Altura total en m.

* Altura máxima de aspiración manométrica 1-2 m.
◻ Carga positiva mínima 1 m.
Tolerancias según ISO 9906, anexo A.

Intensidades nominales

P ₂		230V Δ / 400V Y 400V Δ / 690V Y			IA/IN
kW	HP	IN A	IN A	IN A	
0,55	0,75	3	1,7		4,3
0,75	1	4	2,3		5,2
1,1	1,5	5	2,9		5,3
1,5	2	7,5	4,3		5,8
2,2	3	9,15	5,3		6
3	4	11,5	6,6		9
4	5,5		9,6	5,5	9,3
5,5	7,5		12	7	8,3
7,5	10		16	9,2	8,8
9,2	12,5		18,5	10,7	8,3
11	15		21,5	12,4	8,4
15	20		27,5	15,9	8,8
18,5	25		34	19,6	9,7
22	30		42	24,2	9
30	40		54	31,2	9
37	50		68	39,5	8,5
45	60		85	49	8
55	75		105	60	7,2
75	100		140	81	6

P₂ Potencia nominal del motor.
IA/IN Intensidad de arranque / Intensidad nominal

Curvas Características $n \approx 2900$ 1/min

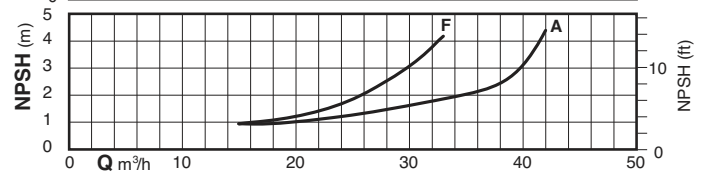
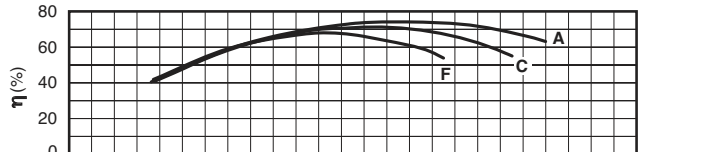
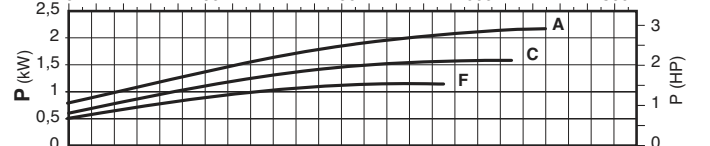
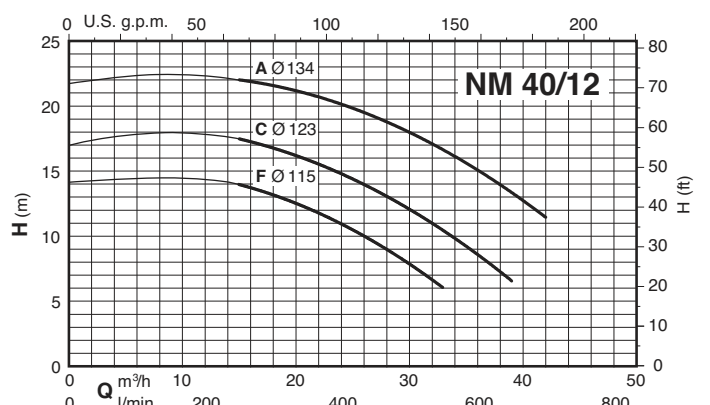
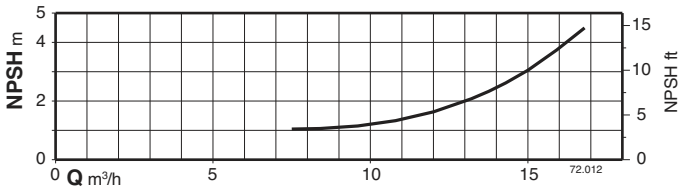
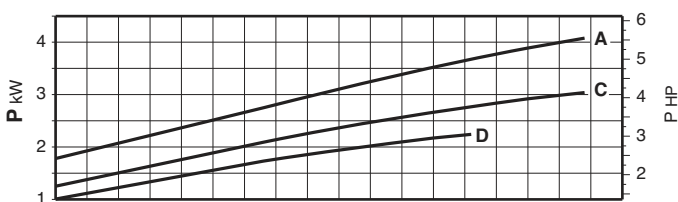
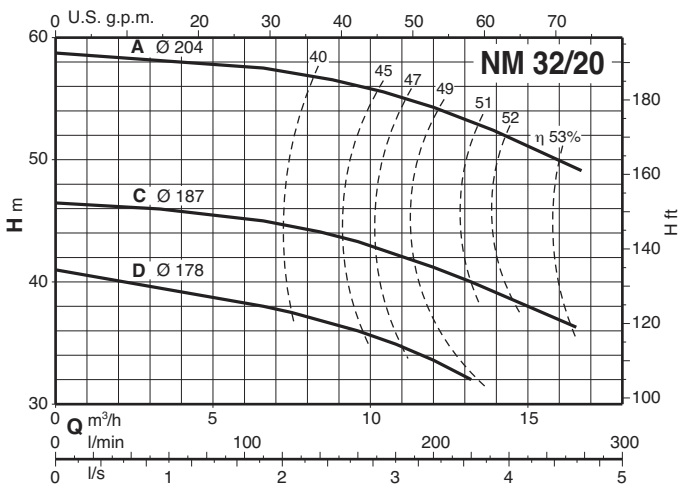
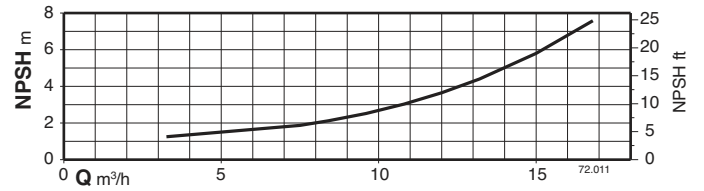
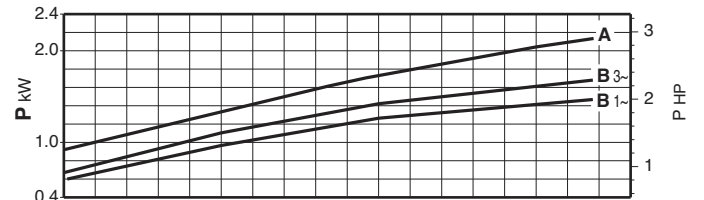
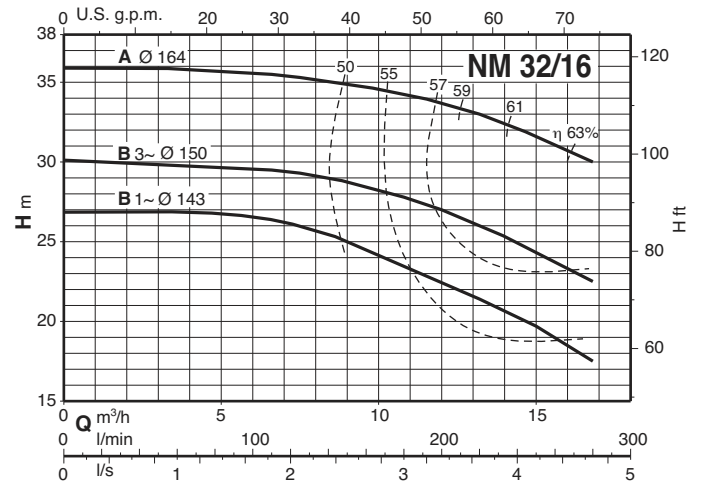
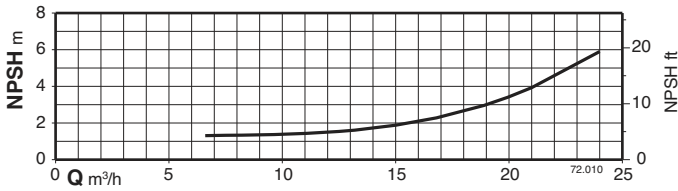
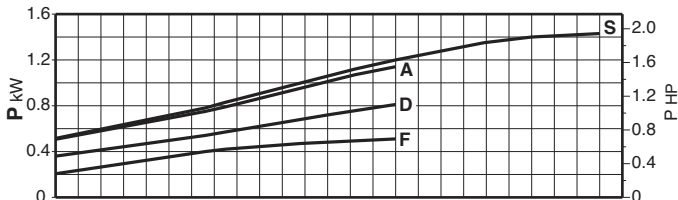
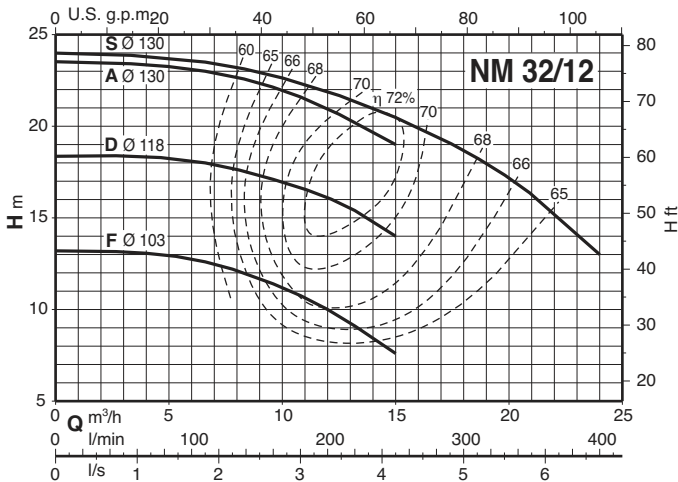

Curvas Características $n \approx 2900$ 1/min

2

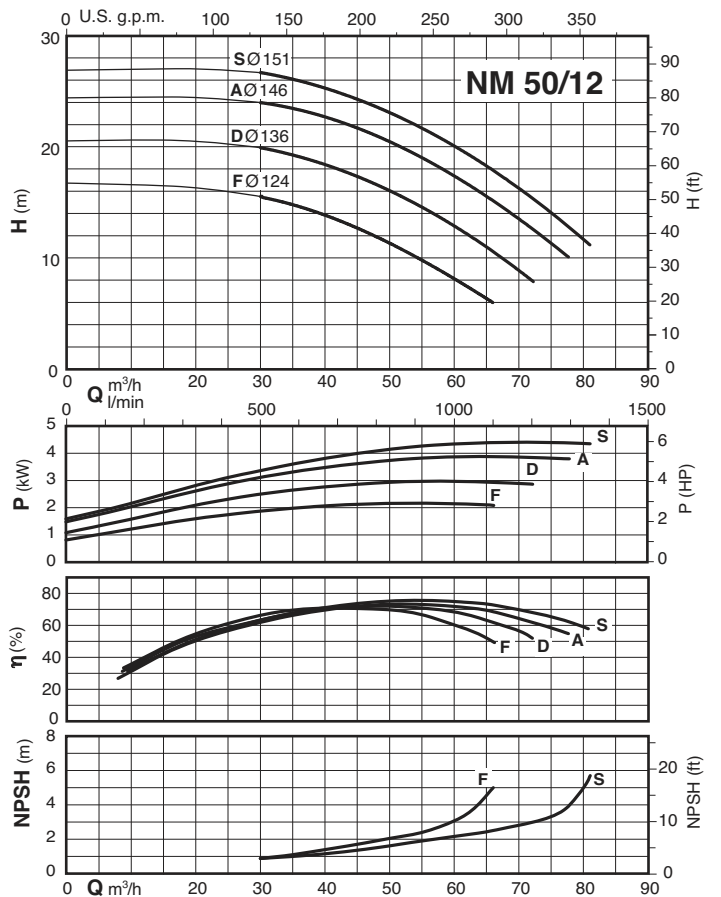
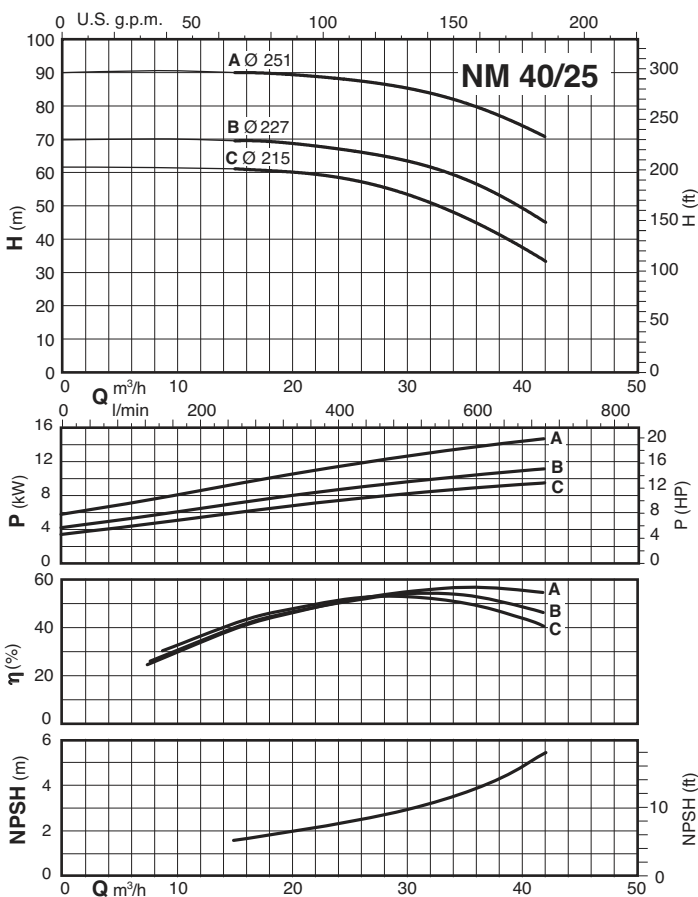
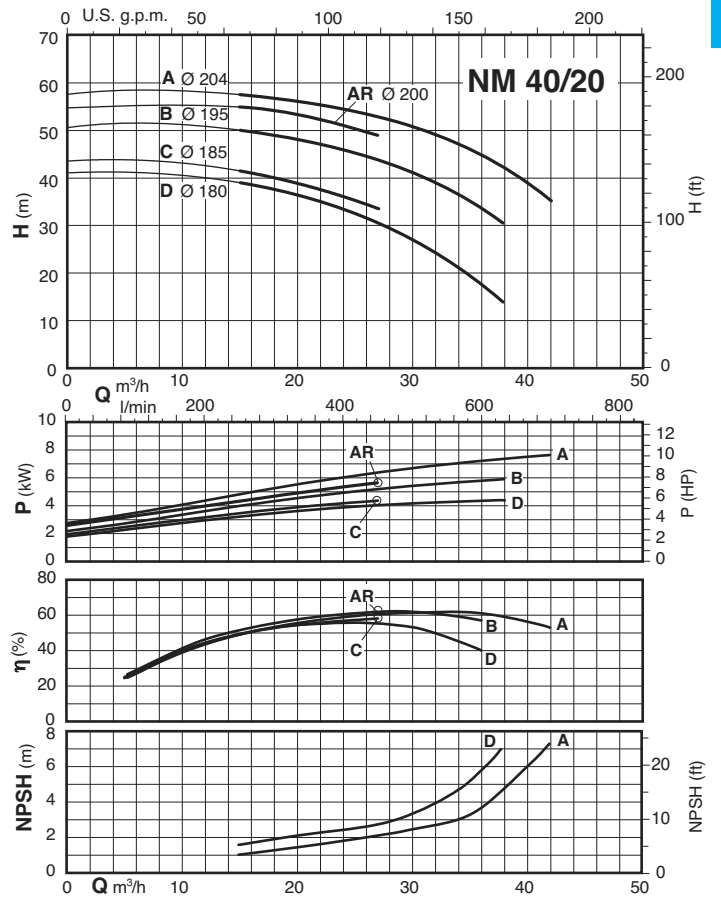
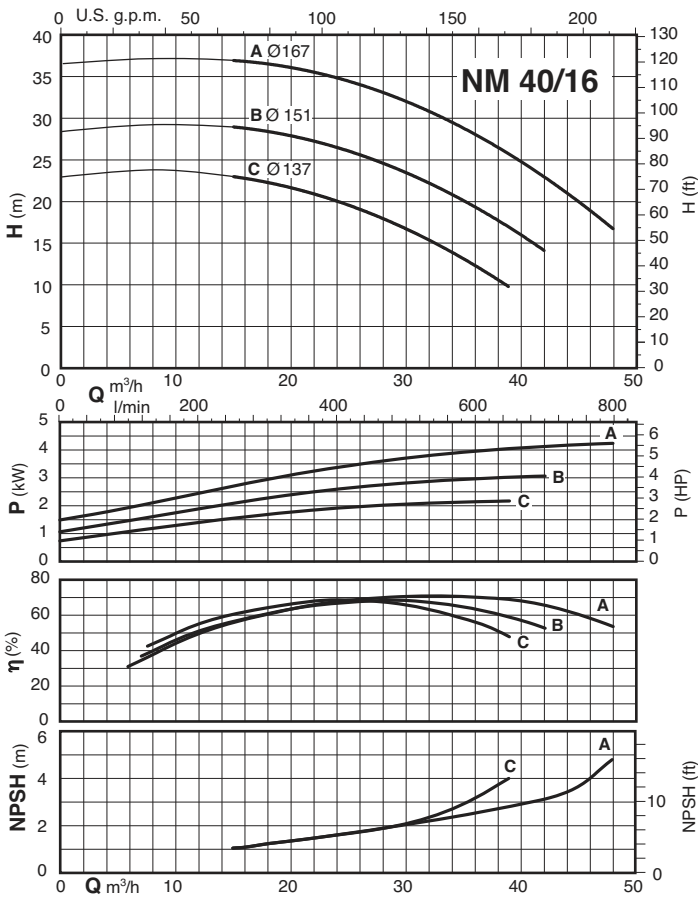

Curvas Características $n \approx 2900$ 1/min

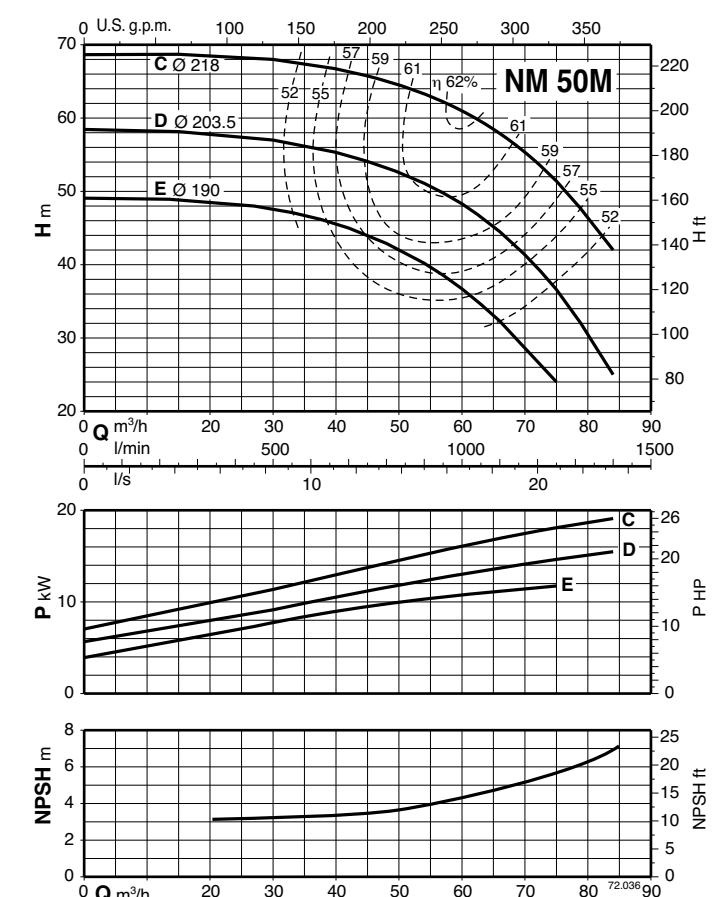
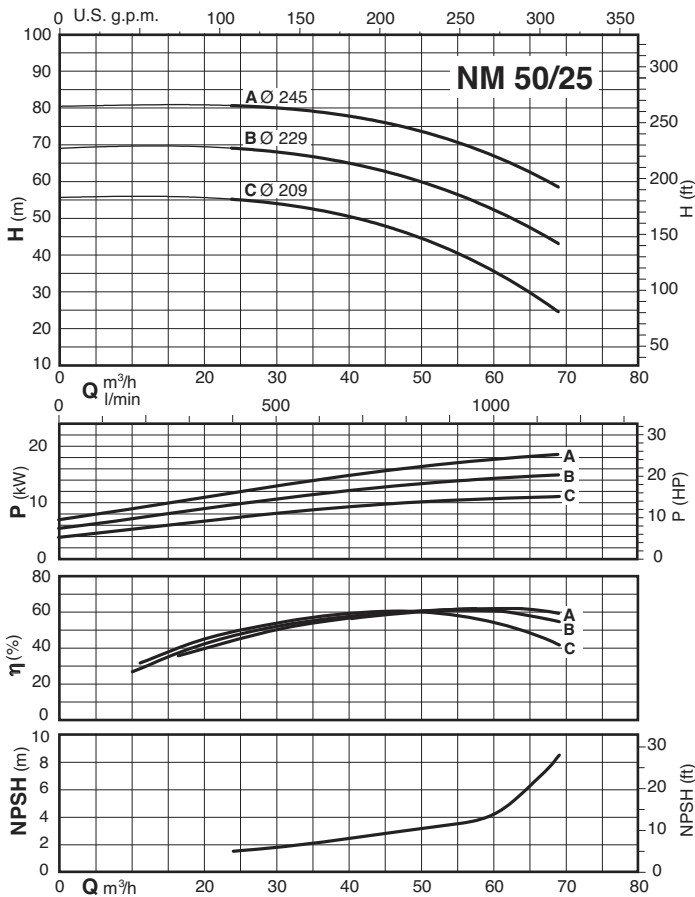
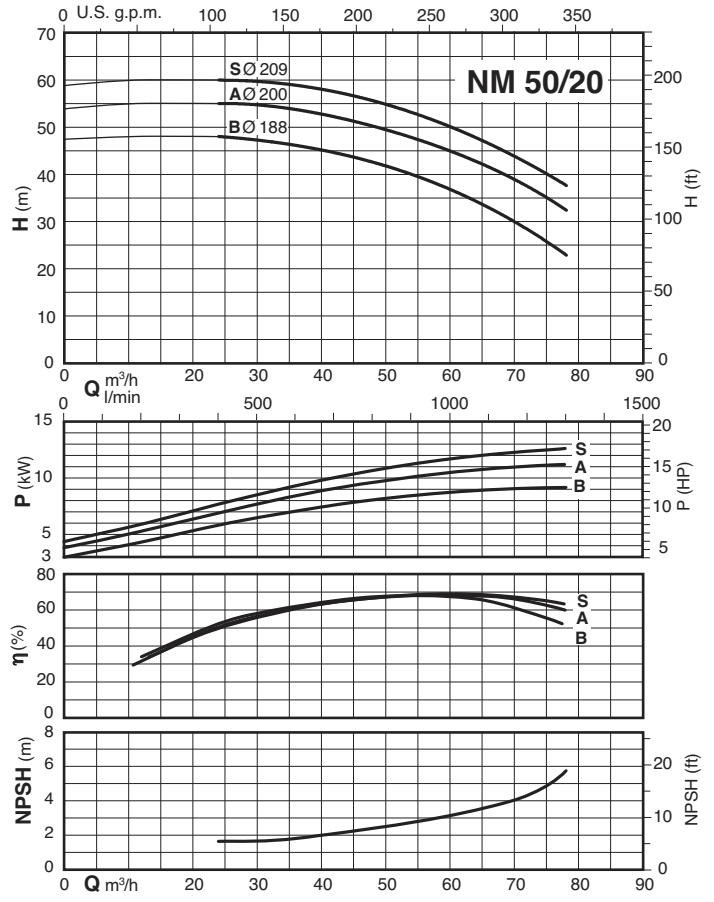
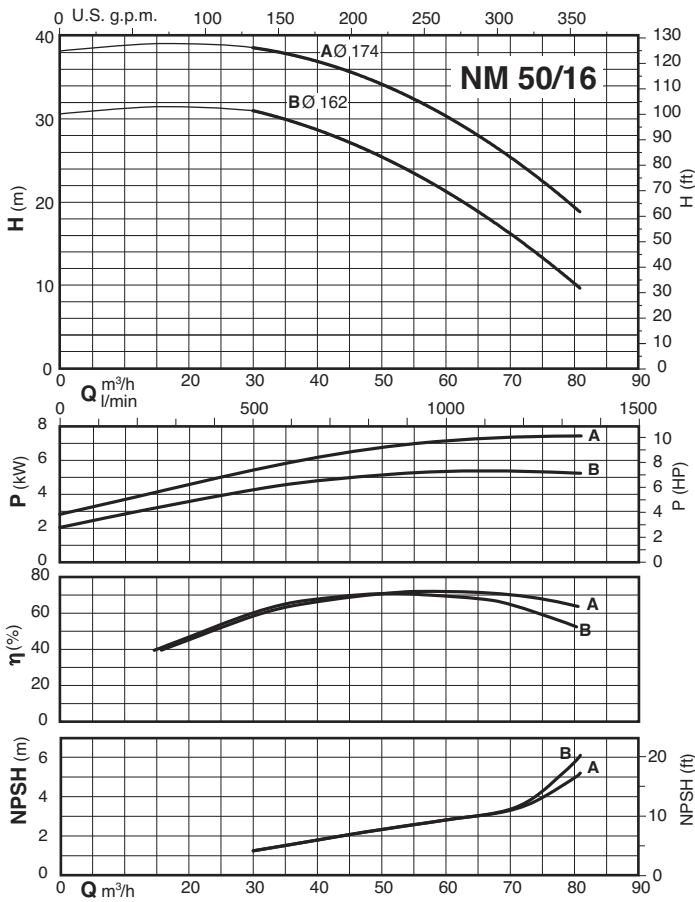

Curvas Características $n \approx 2900$ 1/min

2

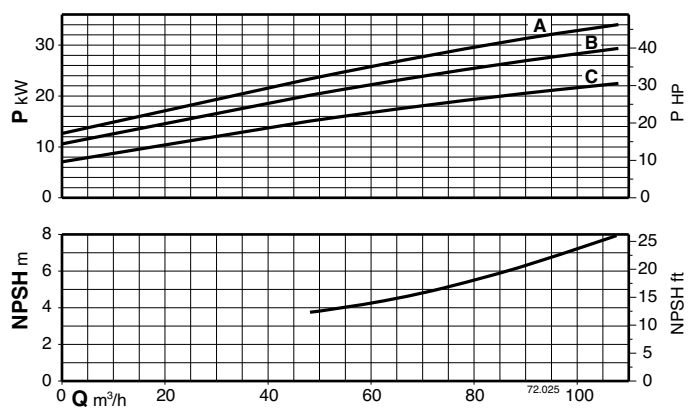
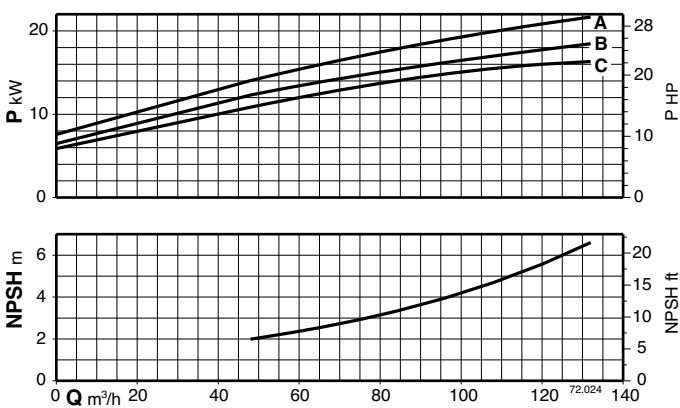
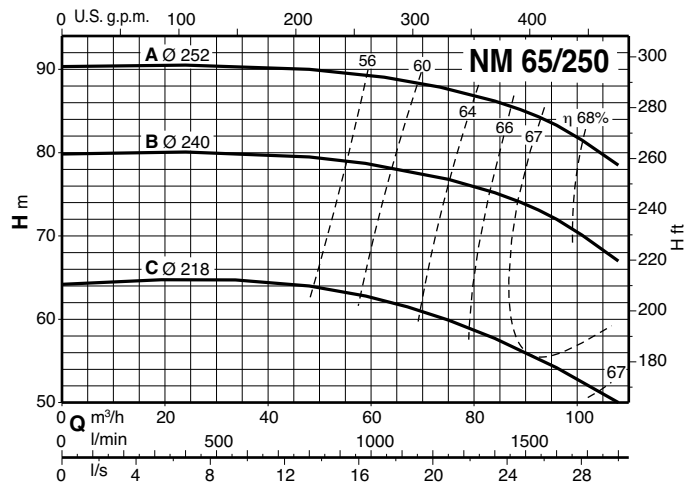
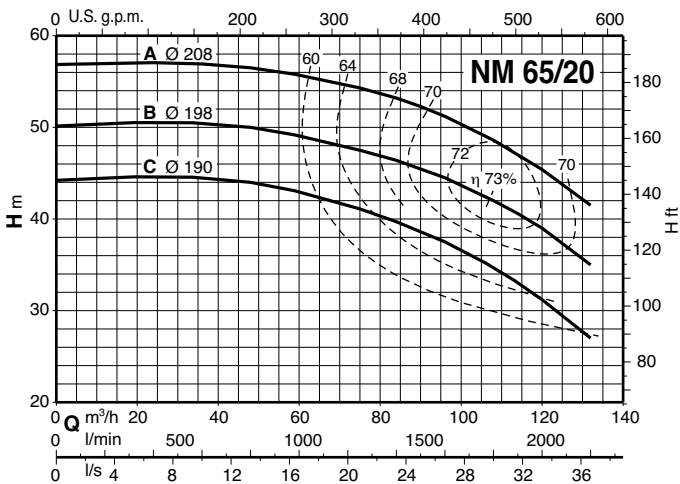
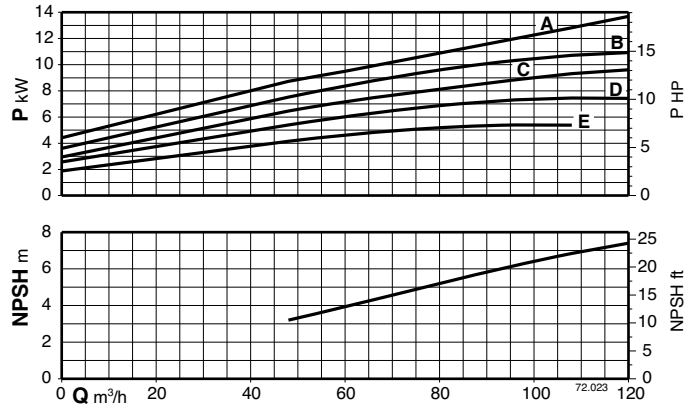
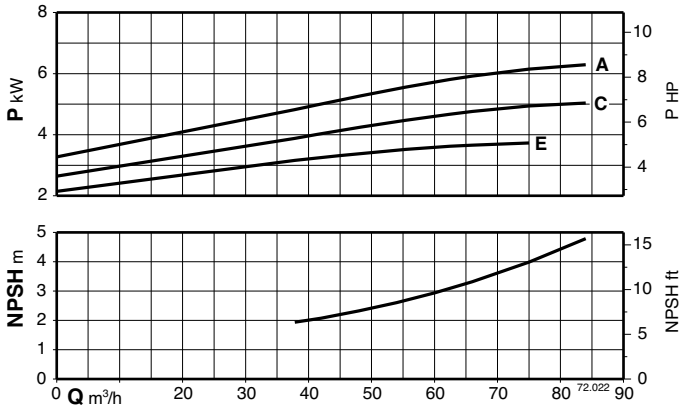
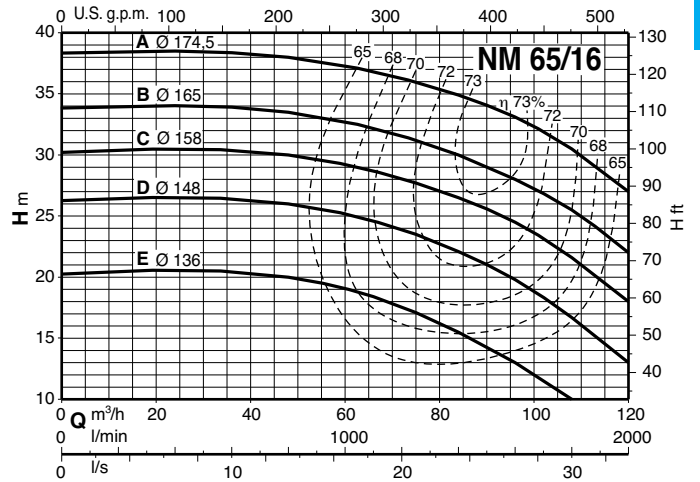
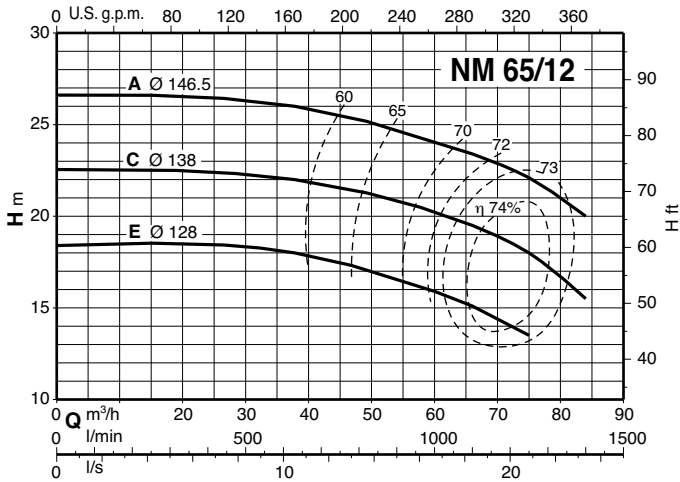

Curvas Características $n \approx 2900$ 1/min

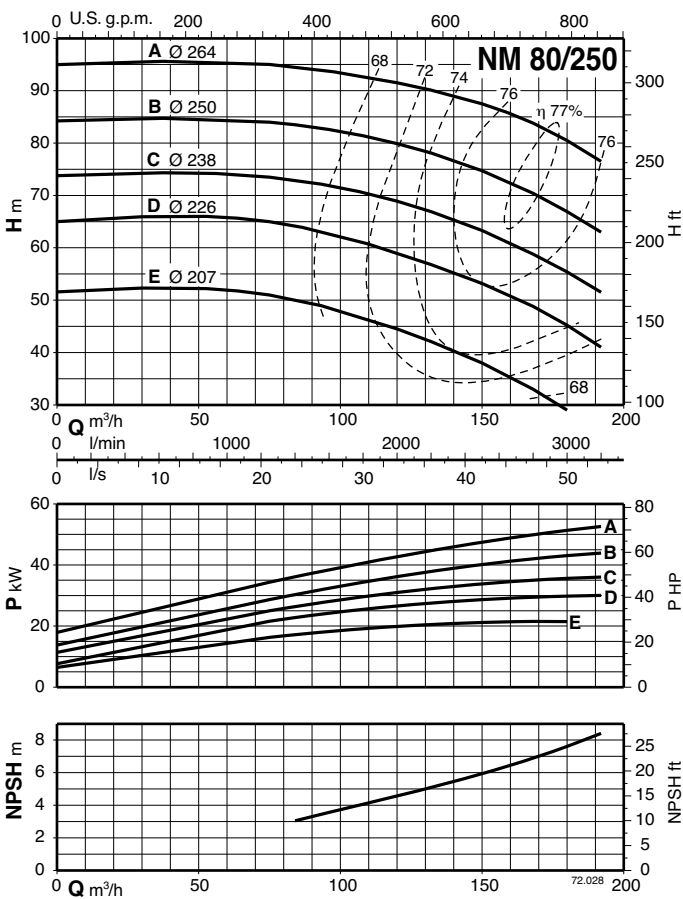
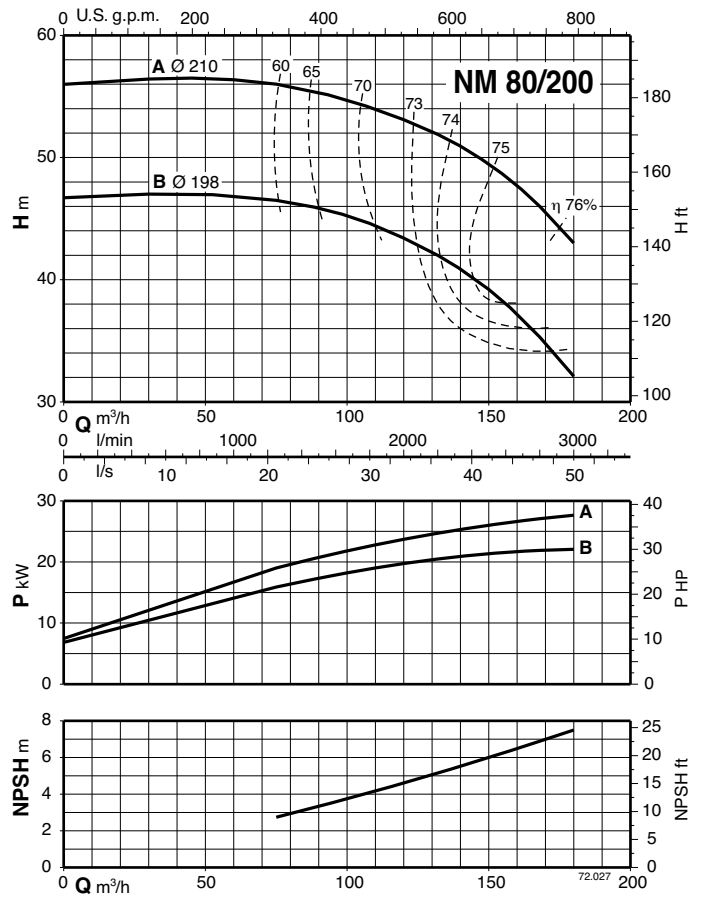
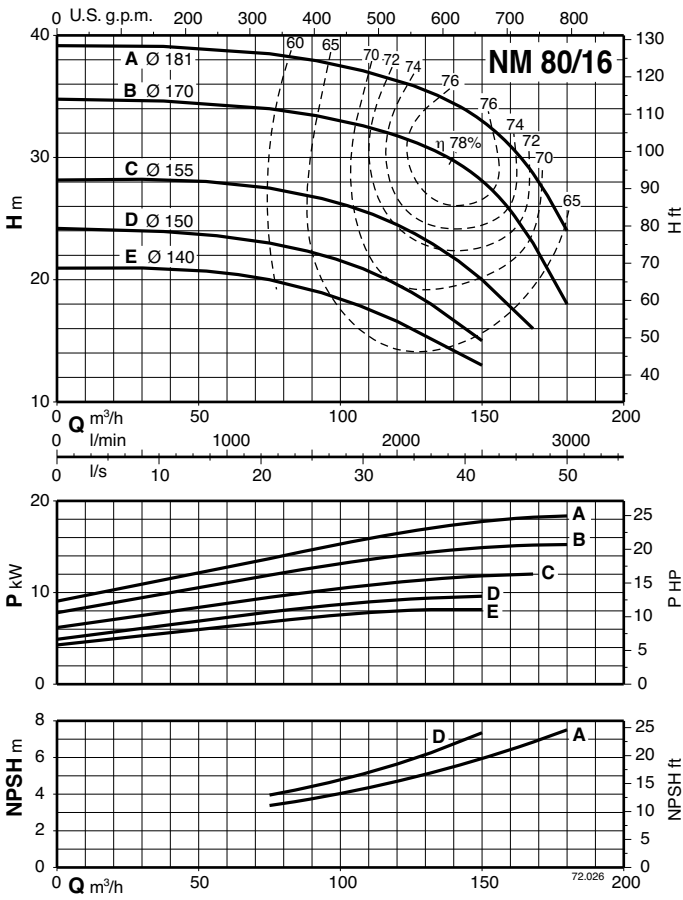

Curvas Características $n \approx 2900$ 1/min

2

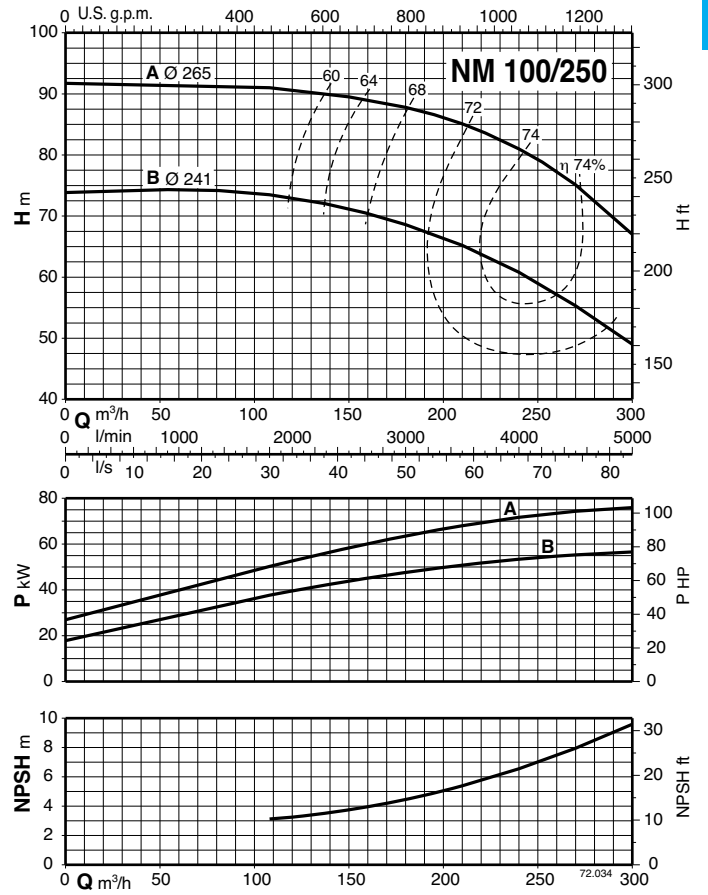
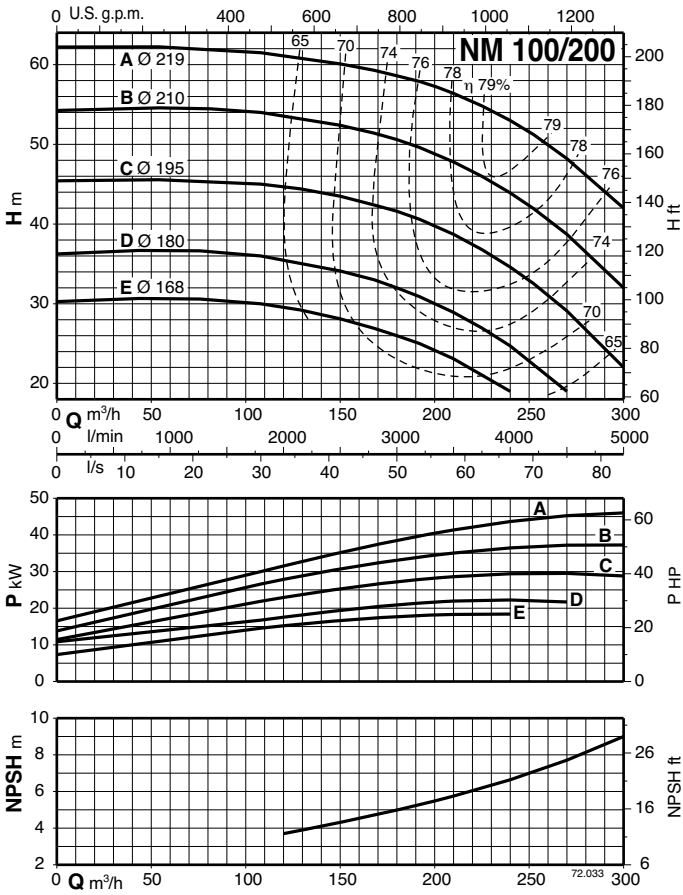

Dimensiones y pesos



Figura	NM	mm																			kg											
		DN1	DN2	a	f	h1	h2	h3	m1	m2	n1	n2	n3	z	b	s	l	l1	l2	w		g1										
1	NM 32/12SE-AE-DE-FE	50	32	80	405	112	140	240	100	70	190	140	37	-	50	14	-	93	97	245	12	27-25-24-24										
	NM 32/16AE-BE	50	32	80	410	132	160	260	100	70	240	190	47	-	50	14	-	120	120	250	12	36-34										
	NM 32/20DE	50	32	80	410	160	180	288	100	70	240	190	62	-	50	14	-	140	140	250	12	39										
	NM 32/20CE				60								295							49												
	NM 32/20AE				60								295							52												
	NM 40/12A/A-C/A-F/A	65	40	80	410	112	140	240	100	70	210	160	37	-	50	14	-	100	113	250	12	31-29-27										
	NM 40/16C/A	65	40	80	410	132	160	260	100	70	240	190	47	-	50	14	-	119	119	250	12	36										
	NM 40/16B/A				45								295							45												
	NM 40/16A/A				45								295							49												
	NM 40/20CE-DE	65	40	100	495	160	180	288	100	70	265	212	60	-	50	14	-	140	140	295	12	55-55										
	NM 40/20AE-ARE-BE				525			320					49							72-65-65												
	NM 40/25B/A-C/A	65	40	100	640	180	225	365	125	95	320	250	50	-	65	14	-	175	175	410	15	116-110										
	NM 40/25A/A				690								133							460		133										
	NM 50/12F/A	65	50	100	430	132	160	260	100	70	240	190	47	-	50	14	-	121	137	250	12	38										
NM 50/12D/A	495				45								295							47												
NM 50/12A/A-S/A	495				45								295							51-51												
NM 50/16A/A-B/A	65	50	100	525	160	180	320	100	70	265	212	49	-	50	14	-	127	141	320	14	70-64											
NM 50/20A/A-B/A	65	50	100	640	160	200	345	100	70	265	212	40	-	50	14	-	140	153	410	15	106-100											
NM 50/20S/A				695															112		460	112										
NM 50/25C/A	65	50	100	645	180	225	365	125	95	320	250	50	-	65	14	-	175	175	415	15	126											
NM 50/25B/A				695															465		132											
NM 50/25A/A				720															465		147											
NM 50M/EE	65	50	100	700	192	225	377	298	258	262	216	-	20	69	12	-	175	175	239	6*	135											
NM 50M/DE				750															151													
NM 50M/CE				775															165													
NM 65/12EE	80	65	100	495	160	180	288	125	95	280	212	60	-	65	14	-	134	156	295	15	55											
NM 65/12AE-CE				525			320					73-67																				
NM 65/16DE-EE	80	65	100	525	160	200	320	125	95	280	212	49	-	65	14	-	150	172	320	15	75-70											
NM 65/16BE-CE				640			410					106-100																				
NM 65/16AE				690			460					121																				
NM 65/20CE	80	65	100	690	180	225	365	125	95	320	250	50	-	65	14	-	155	175	460	15	127											
NM 65/20BE				715															139													
NM 65/200AE	80	65	100	825	202	225	408	400	360	344	254	-	20	90	14	-	155	175	245	42	164											
NM 65/250BE-CE	80	65	100	825	202	250	408	400	360	344	254	-	20	90	14	-	175	190	245	42	195-174											
NM 65/250AE				945			245												-		475	425	408	318	-	25	90	18	290	263	45	299
NM 80/16EE	100	80	125	545	180	225	340	125	95	320	250	60	-	65	14	-	165	193	320	15	83											
NM 80/16CE-DE				670			365					113-108																				
NM 80/16BE				720			365					130																				
NM 80/16AE				745			365					144																				
NM 80/200AE-BE	100	80	125	850	202	250	408	400	360	344	254	-	20	90	14	-	170	194	245	42	194-173											
NM 80/250DE-EE	100	80	125	850	202	280	408	400	360	344	254	-	20	90	14	-	191	210	245	42	203-182											
NM 80/250AE-BE-CE				970			245												-		475	425	408	318	-	25	90	18	290	263	45	377-361-331
NM 100/200EE	125	100	125	800	192	280	377	400	360	344	254	-	20	69	12	-	180	212	239	6*	173											
NM 100/200CE-DE				850			202												408		400	360	344	254	-	20	90	14	290	245	42	195-174
NM 100/200AE-BE				970			245												-		475	425	408	318	-	25	90	18	290	263	45	355-323
NM 100/250BE	125	100	140	980	245	280	-	475	425	408	318	-	25	90	18	290	205	233	263	45	386											
NM 100/250AE				1050															275		-	480	430	460	356	-	104	18	330	305	50	498

Bridas EN 1092-2

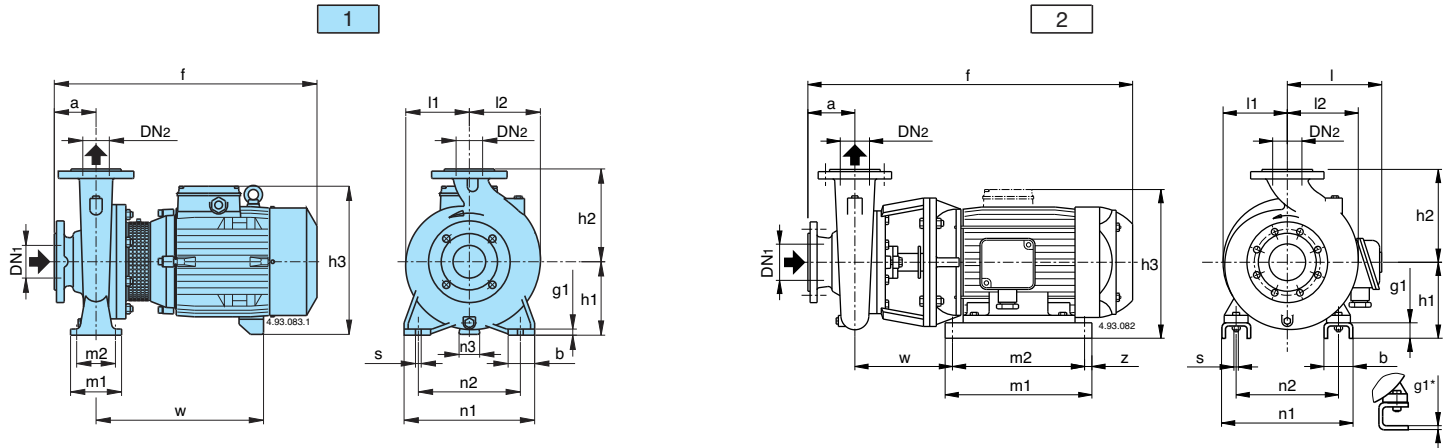
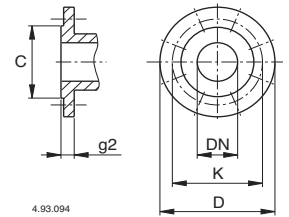

mm					
DN	C	K	D	Agujeros N° Ø	g2
32	76	100	140	4 19	18
40	84	110	150	4 19	18
50	99	125	165	4 19	20
65	118	145	185	4 19	20
80	132	160	200	8 19	22
100	156	180	220	8 19	24
125	184	210	250	8 19	24

Dimensiones y pesos

2



Figura	B- NM	mm																			kg	
		DN1	DN2	a	f	h1	h2	h3	m1	m2	n1	n2	n3	z	b	s	l	l1	l2	w	g1	B-NM
3	B-NM 32/125SE-AE B-NM 32/125DE-FE	50	32	80	450	112	140	240	100	70	190	140	37	-	50	14	-	93	97	290	12	33-32 31-29
	B-NM 32/160BE B-NM 32/160AE	50	32	80	455 475	132	160	260	100	70	240	190	47	-	50	14	-	120	120	295 315	12	44 45
	B-NM 32/200DE B-NM 32/200CE B-NM 32/200AE	50	32	80	475 530 530	160	180	288	100	70	240	190	60 60	-	50	14	-	140	140	315 350 350	12	49 57 61
	B-NM 40/125F/A B-NM 40/125A/A-C/A	65	40	80	455 475	112	140	240	100	70	210	160	37	-	50	14	-	100	113	295 315	12	33 37-35
	B-NM 40/160C/A B-NM 40/160B/A B-NM 40/160A/A	65	40	80	475 530 530	132	160	260	100	70	240	190	47 45 45	-	50	14	-	119	119	315 350 350	12	45 53 57
	B-NM 40/200CE-DE B-NM 40/200AE-BE	65	40	100	550 580	160	180	288 320	100	70	265	212	60 49	-	50	14	-	140	140	350 375	12	63-62 80-74
	B-NM 4025/B/A-C/A B-NM 4025/A/A	65	40	100	635 685	192	225	377	298	258	262	216	-	20	69	12	-	175	175	174	6	130-124 147
3	B-NM 50/125F/A B-NM 50/125D/A B-NM 50/125A/A-S/A	65	50	100	495 550 550	132	160	260	100	70	240	190	47 45 45	-	50	14	-	121	137	315 350 350	12	49 58 63-63
	B-NM 50/160A/A-B/A	65	50	100	580	160	180	320	100	70	265	212	49	-	50	14	-	127	141	375	14	80-74
	B-NM 50/200S/A-A/A-B/A	65	50	100	695	192	200	377	298	258	262	216	-	20	69	12	-	140	153	234	6	128-121
4	B-NM 5025/C/A B-NM 5025/B/A B-NM 5025/A/A	65	50	100	635 685 710	192	225	377	298	258	262	216	-	20	69	12	-	175	175	174	6	135 144 155
	B-NM 5025/65EE B-NM 5025/65DE B-NM 5025/65CE	65	50	100	635 685 710	192	225	377	298	258	262	216	-	20	69	12	-	175	175	174	6	135 144 155
	B-NM 65/125AE-CE B-NM 65/160DE-EE B-NM 65/160CE	80	65	100	580 575 660	160	200	320 345	125	95	280	212	49 40	-	65	14	-	134 150	156 172	375 430	15	93-72 83-78 108
4	B-NM 65/160BE B-NM 65/160AE	80	65	100	695 745	192	200	377	298	258	262	216	-	20	69	12	-	150	172	234	6	149 166
	B-NM 65/200CE B-NM 65/200BE B-NM 65/200AE	80	65	100	750 775 825	192 192 202	225 225 202	377 377 408	298 298 400	258 258 360	262 262 344	216 216 254	-	20	69 69 90	12 12 14	-	155	175	239 239 245	6 6 42*	157 177 179
	B-NM 65/250BE-CE NM 65/250BE B-NM 65/250AE	80	65	100	825 840 945	202 222 245	250 - -	408 387 475	400 347 425	360 347 425	344 369 408	254 279 318	-	20 20 25	90 90 90	14 14 18	- 270 290	175	190	245 258 263	42* 42* 45*	210-189 350
	B-NM 80/160EE B-NM 80/160DE	100	80	125	605 685	180	225	340 365	125	95	320	250	60 50	-	65	14	-	165	193	375 430	15	108 116
	B-NM 80/160CE B-NM 80/160BE B-NM 80/160AE	100	80	125	725 775 800	192	225	377	298	258	262	216	-	20	69	12	-	165	193	239	6	155 163 166

Bridas EN 1092-2

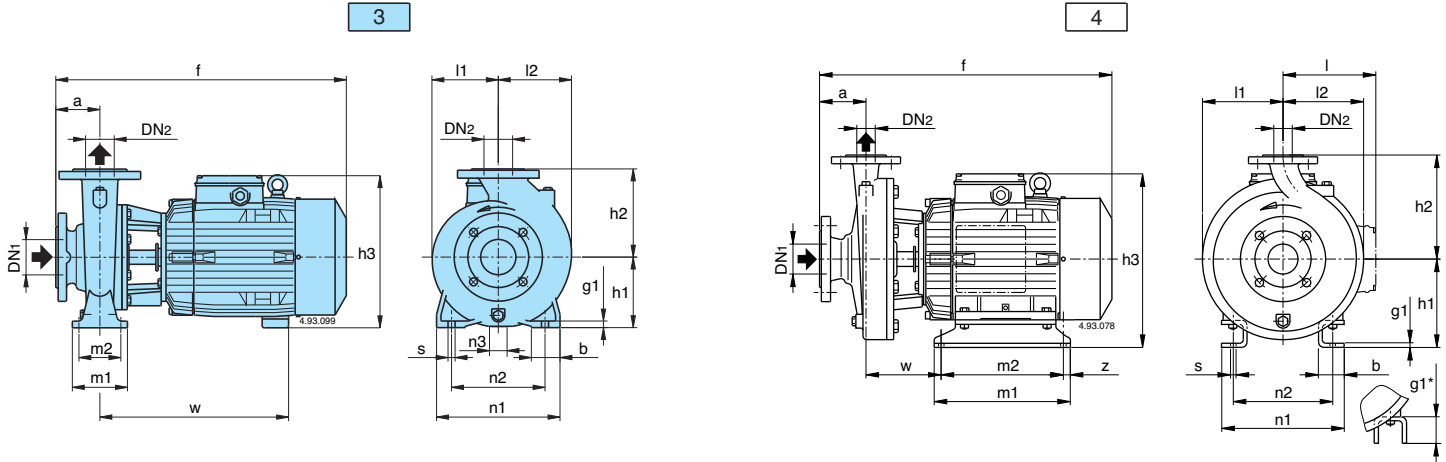
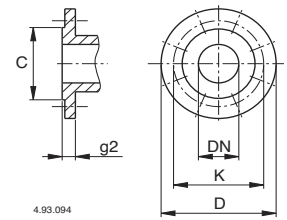

mm					
DN	C	K	D	Agujeros N° Ø	g2
32	76	100	140	4 19	18
40	84	110	150	4 19	18
50	99	125	165	4 19	20
65	118	145	185	4 19	20
80	132	160	200	8 19	22
100	156	180	220	8 19	24
125	184	210	250	8 19	24