



Data sheet

# Solenoid Valve

## Types EVR 2 – 40



EVR is a direct or servo operated solenoid valve for liquid, suction, and hot gas lines using fluorinated refrigerants.

EVR valves are supplied as separate components, ie. valve body and coils should be ordered separately.

### Features

- A complete range of solenoid valves for refrigeration, freezing and air conditioning systems
- Normally closed (NC) and normally open (NO) versions available
- a.c. and d.c. coils are interchangeable on all valve body versions
- Use with any fluorinated refrigerant
- Designed for media temperatures up to 220 °F
- Flare connections up to  $\frac{5}{8}$  in.
- Solder connections up to  $2 - \frac{1}{8}$  in.
- Solder versions have extended connections; there is no need to dismantle the valve when soldering

### Approvals

UL listed, file MH 7648

### Note:

These approvals are only recognized when one of the EVR series of solenoid valves found in this leaflet is combined with a GP general purpose coil.

**Technical data**

Refrigerant  
R22/R407C, R404A/R507, R410A, R134a,  
R407A, R23. For other refrigerants,  
please contact Danfoss.

Maximum working pressure  
EVR 2 – 8: MWP = 655 psig  
EVR 10 – 20: MWP = 500 psig  
EVR 22 – 40: MWP = 460 psig

Temperature of medium  
-40 – 220 °F  
Maximum 265 °F during defrosting

Enclosure of coil  
~ NEMA 2 or ~ NEMA 4

Valve type	Opening differential pressure $\Delta p$ [psi]			Medium temperature [°F]	Maximum working pressure MWP [psig]	$C_v$ value <sup>1)</sup> [gal/min]
	Minimum	Maximum (= MOPD) liquid <sup>2)</sup>				
		a.c.	d.c.			
EVR 2	0.0	350	260	-40 – 220	655	0.19
EVR 3	0.0	300	260	-40 – 220	655	0.32
EVR 4	0.7	300	260	-40 – 220	655	0.66
EVR 6	0.7	300	260 <sup>3)</sup>	-40 – 220	655	0.93
EVR 8	0.7	300	260	-40 – 220	655	1.3
EVR 10	0.7	300	260 <sup>3)</sup>	-40 – 220	500	2.2
EVR 15	0.7	300	260 <sup>3)</sup>	-40 – 220	500	3.0
EVR 18	0.7	300	260	-40 – 220	500	3.9
EVR 20	0.7	300 <sup>4)</sup>	190	-40 – 220	500	5.8
EVR 22	0.7	300 <sup>4)</sup>	190	-40 – 220	460	6.9
EVR 25	1.0	300	260	-40 – 220	460	12.0
EVR 32	1.0	300	260	-40 – 220	460	18.0
EVR 40	1.0	300	260	-40 – 220	460	29.0

*Metric conversions*  
 $\frac{5}{9}(t_1 \text{ °F} - 32) = t_2 \text{ °C}$   
1 in. = 25.4 mm

<sup>1)</sup>  $C_v$  value is the water flow in [gal/min] at a pressure drop  
across valve  $\Delta p = 1$  psi,  $\rho = 10$  lbs/gal

<sup>3)</sup> EVR (NO): 300 psig

<sup>4)</sup> EVR (NO): 275 psig

<sup>2)</sup> MOPD (Max. Opening Pressure Differential) for media in gas  
form is approximately 14 psi greater

Technical data

Valve type	Rated capacity <sup>1)</sup> [TR]								
	Liquid			Suction vapor			Hot gas		
	R22 /R407C	R134a	R404A /R507	R22/ R407C	R134a	R404A /R507	R22/ R407C	R134a	R404A /R507
<b>EVR 2</b>	1.17	0.89	0.80	0.10	0.07	0.09	0.22	0.18	0.17
<b>EVR 3</b>	2.03	1.55	1.40	0.17	0.13	0.15	0.38	0.31	0.30
<b>EVR 4</b>	4.15	3.16	2.86	0.34	0.26	0.30	0.77	0.63	0.62
<b>EVR 6</b>	5.83	4.43	4.01	0.48	0.37	0.43	1.08	0.88	0.87
<b>EVR 8</b>	8.01	6.09	5.52	0.66	0.51	0.58	1.49	1.21	1.19
<b>EVR 10</b>	13.8	10.5	9.53	1.15	0.88	1.01	2.57	2.10	2.06
<b>EVR 15</b>	18.9	14.4	13.0	1.57	1.20	1.38	3.52	2.87	2.82
<b>EVR 18</b>	24.6	18.7	17.0	2.04	1.56	1.80	4.57	3.73	3.67
<b>EVR 20</b>	36.4	27.7	25.1	3.02	2.31	2.66	6.76	5.51	5.43
<b>EVR 22</b>	43.7	33.3	30.1	3.62	2.78	3.19	8.11	6.62	6.52
<b>EVR 25</b>	72.8	55.4	50.2	6.04	4.63	5.32	13.5	11.0	10.9
<b>EVR 32</b>	116.5	88.7	80.3	9.66	7.40	8.51	21.6	17.7	17.4
<b>EVR 40</b>	182.0	138.5	125.4	16.1	11.6	13.3	33.8	27.6	27.2

*Metric conversions*  
 1 psi = 0.07 bar  
 $\frac{5}{9}(t_1 \text{ } ^\circ\text{F} - 32) = t_2 \text{ } ^\circ\text{C}$   
 1 TR = 3.5 kW  
 1 in. = 25.4 mm  
 US gal/min = 0.86 m<sup>3</sup>/h

<sup>1)</sup> Rated liquid and suction vapor capacity are based on:  
 Evaporating temperature  $t_e = 40 \text{ } ^\circ\text{F}$   
 Liquid temperature ahead of valve  $t_l = 100 \text{ } ^\circ\text{F}$   
 Pressure drop  $\Delta p$  across valve  
 – with liquid  $\Delta p = 2 \text{ psi}$  for R134a  
 $\Delta p = 3 \text{ psi}$  for R22/R407C, R404A/R507  
 – with suction vapor  $\Delta p = 1 \text{ psi}$

Rated hot gas capacity is based on:  
 – Condensing temperature  $t_c = 100 \text{ } ^\circ\text{F}$   
 – Hot gas temperature  $t_h = 140 \text{ } ^\circ\text{F}$   
 – Pressure drop across valve  $\Delta p = 2 \text{ psi}$

Ordering

Separate valve bodies for EVR, normally closed (NC)

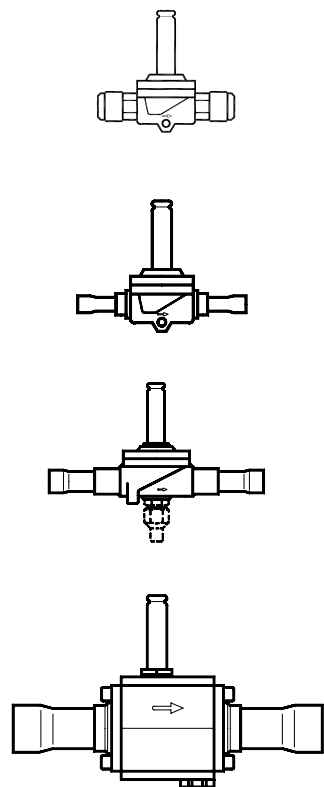

Type	Rated capacity R22/R407C (liquid)  [TR]	Connection  [in.]	Port size  [in.]	C <sub>v</sub> value  [gal/min]	Code nos. valve body excl. coil		
					Flare		Solder ODF
					Without manual stem [in.]	With manual stem [in.]	Without manual stem [in.]
EVR 2	1.17	1/4	3/32	0.19	—	—	32F7100
EVR 3	2.03	1/4	1/8	0.32	32F8106	—	32F7105
EVR 3	2.03	3/8	1/8	0.32	32F8115	—	32F1157
EVR 4	4.15	3/8	5/32	0.66	32F8087	—	32F7110
EVR 6	5.83	3/8	15/64	0.93	32F8071	32F7116	32F7115
EVR 6	5.83	1/2	15/64	0.93	—	32F7144	32F1162
EVR 6	5.83	5/8	15/64	0.93	—	—	32F7117
EVR 8	8.01	1/2	5/16	1.3	—	032F7148	32F7121
EVR 8	8.01	5/8	5/16	1.3	—	—	32F7122
EVR 10	13.8	3/8	3/8	2.2	—	—	32F7125
EVR 10	13.8	1/2	3/8	2.2	—	32F1188	32F1166
EVR 10	13.8	5/8	3/8	2.2	—	32F7149	32F1168
EVR 15	18.9	5/8	9/16	3.0	—	32F1172	32F1171
EVR 15	18.9	7/8	9/16	3.0	—	—	32F7130
EVR 18	24.6	7/8	19/32	3.9	—	32F1004	—
EVR 20	36.4	7/8	7/8	5.8	—	32F1177	32F1176
EVR 22	43.7	1 1/8	15/16	6.9	—	32F7137	32F7145
EVR 22	43.7	1 3/8	15/16	6.9	—	—	32F7146
EVR 25	72.8	1 1/8	1	12.0	—	32F1190	32F1189
EVR 25	72.8	1 3/8	1	12.0	—	32F1194	32F1193
EVR 32	116.5	1 3/8	7/8	18.0	—	42H1177	42H1176
EVR 32	116.5	1 5/8	7/8	18.0	—	42H1179	42H1178
EVR 32	116.5	2 1/8	7/8	18.0	—	42H1181	42H1180
EVR 40	182.0	2 1/8	1	29.0	—	42H1188	—

Metric conversions

1 psi = 0.07 bar

5/9 (t<sub>1</sub> °F - 32) = t<sub>2</sub> °C

1 TR = 3.5 kW

1 in. = 25.4 mm

US gal/min = 0.86 m<sup>3</sup>/h

**Ordering**  
(continued)

Separate valve bodies for EVR, normally open (NO)

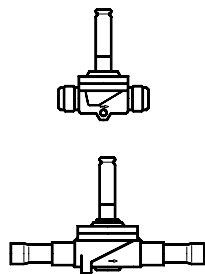

Type	Rated capacity R22/R407C (liquid) [TR]	Connection [in.]	Port size [in.]	C <sub>v</sub> value [gal/min]	Code nos. valve body excl. coil	
					Flare [in.]	Solder ODF [in.]
EVR 6	5.8	3/8	1/4	0.93	—	<b>32F1164</b>
EVR 10	13.8	1/2	3/8	2.2	—	<b>32F1169</b>
EVR 15	18.9	5/8	9/16	3.0	—	<b>32F1174</b>

*Metric conversions*

1 psi = 0.07 bar  
 $\frac{5}{9} (t_1 \text{ } ^\circ\text{F} - 32) = t_2 \text{ } ^\circ\text{C}$   
 1 TR = 3.5 kW  
 1 in. = 25.4 mm  
 US gal/min = 0.86 m<sup>3</sup>/h

*Coils*  
see next page

*Accessories*

Mounting bracket for EVR 2, EVR 3,  
 EVR 4, EVR 6 and EVR 10  
 Code no. **32F0086**

Coils for EVR valves



Features

- For high temperatures – class H insulated wire
- Encapsulated coils with long life time
- Wide range of coils
  - from 24 V – 240 V a.c.
  - Junction box and Conduite boss

Approvals

Listed with EVR, MH7648  
Low Voltage Directive (LVD) 2006/95/EC

**Note:**

These approvals are only recognized when one of the EVR series of solenoid valves found in this leaflet is combined with a GP (General purpose) coil

Technical data

<b>Design</b>	In accordance with UL 429
<b>Power supply</b>	Alternating current (a.c.)
<b>Permissible voltage variation</b>	Alternating current (a.c.): -15 – 10%
<b>Power consumption</b>	Alternating current (a.c.): In rush: 49 VA; Holding: 28 VA, 14 W
<b>Insulation of coil wire</b>	Class H according to IEC 85
<b>Connection</b>	Junction box or Conduit boss
<b>Enclosure, IEC 529</b>	Junction box NEMA 1 IP12 – IP32 / Conduit boss ~ NEMA 4 IP54
<b>Ambient temperature</b>	-40 – 122 °F (-40 – 50 °C)

Ordering

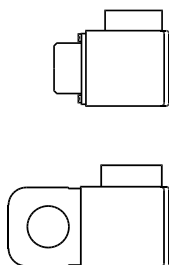

Voltage [V]	Frequency [Hz]	Code no.		Power consumption
		Junciton Box ~ NEMA 2	Conduit Boss ~ NEMA 4	
24	50/60	<b>018F7683</b>	<b>018F7693</b>	Holding: 14 W 28 VA In rush: 49 VA
110	50/60	<b>018F7682</b>	<b>018F7692</b>	
120	60	<b>018F7682</b>	<b>018F7692</b>	
208 – 240	60	<b>018F7681</b>	<b>018F7691</b>	
230	50	<b>018F7681</b>	<b>018F7691</b>	

**Coils for EVR valves**  
(continued)



**Features**

- For high temperatures – class H insulated wire
- Encapsulated coils with long life time
- Wide range of coils
  - from 12 V – 200 V d.c.
  - with terminal box IP67 ~ NEMA 6

**Approvals**

Low Voltage Directive (LVD) 2006/95/EC

**Technical data**

<b>Design</b>	In accordance with VDE 0580
<b>Power supply</b>	Direct current (d.c.)
<b>Permissible voltage variation</b>	-10 – 10%
<b>Power consumption</b>	20 W
<b>Insulation of coil wire</b>	Class H according to IEC 85
<b>Connection</b>	Terminal box
<b>Enclosure, IEC 529</b>	IP67 NEMA 6
<b>Ambient temperature</b>	-40 – 122 °F (-40 – 50 °C)

**Ordering**

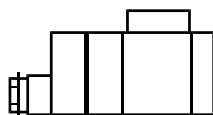

Voltage [V]	Code no.		Power consumption
	EVR 2 – 15 EVR 25 – 40	EVR 20 – 22	
12	<b>018F6856</b>	<b>018F6886</b>	Holding: 20 W
12	<b>018F6857</b>	<b>018F6887</b>	
48	<b>018F6859</b>	<b>018F6889</b>	
110	<b>018F6860</b>	<b>018F6890</b>	
115	<b>018F6861</b>	—	
220	<b>018F6851</b>	<b>018F6881</b>	

**Capacity  
Liquid**

Type	Liquid capacity $Q_0$ [TR] at a pressure drop across valve $\Delta p$ [psi]						
	1	2	3	4	5	6	7
<b>R22/R407C</b>							
EVR 2	0.67	0.95	1.17	1.35	1.50	1.65	1.78
EVR 3	1.18	1.66	2.03	2.35	2.63	2.88	3.11
EVR 4	2.40	3.39	4.15	4.79	5.36	5.87	6.34
EVR 6	3.37	4.76	5.83	6.73	7.52	8.24	8.90
EVR 8	4.62	6.54	8.01	9.24	10.3	11.3	12.2
EVR 10	7.99	11.3	13.8	16.0	17.9	19.6	21.1
EVR 15	10.9	15.5	18.9	21.9	24.4	26.8	28.9
EVR 18	14.2	20.1	24.6	28.4	31.8	34.8	37.6
EVR 20	21.0	29.7	36.4	42.0	47.0	51.5	55.6
EVR 22	25.2	35.7	43.7	50.4	56.4	61.8	66.7
EVR 25	42.1	59.5	72.8	84.1	94.0	103.0	111.0
EVR 32	67.3	95.1	116.5	134.0	150.0	164.8	177.0
EVR 40	105.0	148.6	182.0	210.0	235.0	257.0	278.0
<b>R134a</b>							
EVR 2	0.63	0.89	1.09	1.25	1.40	1.54	1.66
EVR 3	1.10	1.55	1.90	2.19	2.45	2.68	2.90
EVR 4	2.23	3.16	3.87	4.47	5.00	5.47	5.91
EVR 6	3.14	4.43	5.43	6.27	7.01	7.68	8.30
EVR 8	4.31	6.09	7.46	8.62	9.63	10.6	11.4
EVR 10	7.45	10.5	12.9	14.9	16.7	18.2	19.7
EVR 15	10.2	14.4	17.7	20.4	22.8	25.0	27.0
EVR 18	13.3	18.7	23.0	26.5	29.6	32.4	35.0
EVR 20	19.6	27.7	33.9	39.2	43.8	48.0	51.8
EVR 22	23.5	33.3	40.7	47.0	52.6	57.6	62.2
EVR 25	39.2	55.4	67.9	78.4	87.6	96.0	103.0
EVR 32	62.7	88.7	108.0	125.0	140.0	153.0	165.0
EVR 40	98.0	138.5	169.0	195.0	219.0	239.0	259.0

Capacities are based on:  
Liquid temperature  $t_l = 100\text{ }^\circ\text{F}$   
Evaporating temperature  $t_e = 40\text{ }^\circ\text{F}$   
Superheat temperature ( $t_e + 10\text{ }^\circ\text{F}$ ) =  $50\text{ }^\circ\text{F}$

*Metric conversions*  
1 psi = 0.07 bar  
 $\frac{5}{9}(t_1\text{ }^\circ\text{F} - 32) = t_2\text{ }^\circ\text{C}$   
1 TR = 3.5 kW

*Correction factors*

When liquid temperature  $t_l$  ahead of the expansion valve is other than  $100\text{ }^\circ\text{F}$ , adjust the table capacities by multiplying them by the appropriate correction factor found in the following table.

*Correction factors for liquid temperature  $t_l$*

$t_l$ [ $^\circ\text{F}$ ]	80	90	100	110	120
<b>Factor</b>	1.10	1.05	1.00	0.95	0.90



**Capacity  
Liquid**  
(continued)

Type	Liquid capacity $Q_0$ [TR] at a pressure drop across valve $\Delta p$ [psi]						
	1	2	3	4	5	6	7
<b>R404A and R507</b>							
<b>EVR</b>	0.46	0.66	0.80	0.93	1.04	1.13	1.23
<b>EVR 3</b>	0.81	1.14	1.40	1.62	1.81	1.98	2.14
<b>EVR 4</b>	1.65	2.33	2.86	3.30	3.69	4.04	4.37
<b>EVR 6</b>	2.32	3.28	4.01	4.63	5.18	5.67	6.13
<b>EVR 8</b>	3.18	4.50	5.52	6.37	7.12	7.80	8.42
<b>EVR 10</b>	5.50	7.78	9.53	11.0	12.3	13.5	14.6
<b>EVR 15</b>	7.53	10.6	13.0	15.1	16.8	18.4	19.9
<b>EVR 18</b>	9.79	13.8	17.0	19.6	21.9	24.0	25.9
<b>EVR 20</b>	14.5	20.5	25.1	29.0	32.4	35.5	38.3
<b>EVR 22</b>	17.4	24.6	30.1	34.7	38.8	42.5	46.0
<b>EVR 25</b>	29.0	40.9	50.2	57.9	64.7	70.9	76.6
<b>EVR 32</b>	46.3	65.5	80.3	92.6	103.6	113.0	121.0
<b>EVR 40</b>	72.4	102.0	125.0	144.0	162.0	177.0	191.0

*Correction factors*

When liquid temperature  $t_l$  ahead of the expansion valve is other than 100 °F, adjust the table capacities by multiplying them by the appropriate correction factor found in the following table.

*Correction factors for liquid temperature  $t_l$*

$t_l$ [°F]	80	90	100	110	120
<b>Factor</b>	1.10	1.05	1.00	0.95	0.90

Capacity  
Suction vapor

Type	Pressure drop across valve $\Delta p$ [psi]	Suction vapor capacity $Q_0$ [TR] at evaporating temperature $t_e$ [°F]							
		-40	-20	0	10	20	30	40	50
<b>R22/R407C</b>									
EVR 2	1	0.04	0.05	0.06	0.07	0.08	0.09	0.10	0.11
	2	0.05	0.07	0.09	0.10	0.11	0.12	0.14	0.15
	3	0.06	0.08	0.10	0.12	0.13	0.15	0.17	0.18
EVR 3	1	0.06	0.09	0.11	0.12	0.14	0.15	0.17	0.19
	2	0.09	0.12	0.15	0.18	0.19	0.22	0.24	0.26
	3	0.10	0.14	0.18	0.20	0.23	0.26	0.29	0.32
EVR 4	1	0.13	0.18	0.22	0.25	0.28	0.31	0.34	0.38
	2	0.18	0.24	0.31	0.36	0.40	0.44	0.49	0.54
	3	0.21	0.28	0.37	0.42	0.47	0.54	0.60	0.66
EVR 6	1	0.18	0.25	0.32	0.35	0.39	0.44	0.48	0.53
	2	0.25	0.33	0.43	0.50	0.56	0.62	0.68	0.75
	3	0.29	0.40	0.52	0.59	0.66	0.76	0.84	0.92
EVR 8	1	0.25	0.34	0.43	0.49	0.54	0.60	0.66	0.73
	2	0.34	0.46	0.59	0.69	0.77	0.85	0.94	1.03
	3	0.40	0.55	0.71	0.80	0.91	1.04	1.15	1.26
EVR 10	1	0.44	0.59	0.75	0.84	0.94	1.04	1.15	1.26
	2	0.59	0.79	1.02	1.19	1.32	1.47	1.62	1.78
	3	0.69	0.94	1.23	1.39	1.57	1.80	1.98	2.18
EVR 15	1	0.60	0.81	1.02	1.15	1.28	1.42	1.57	1.72
	2	0.80	1.08	1.40	1.63	1.81	2.01	2.22	2.44
	3	0.94	1.29	1.68	1.90	2.14	2.46	2.71	2.99
EVR 18	1	0.78	1.05	1.33	1.50	1.66	1.84	2.04	2.24
	2	1.04	1.41	1.82	2.12	2.35	2.61	2.88	3.17
	3	1.22	1.68	2.19	2.47	2.79	3.20	3.53	3.88
EVR 20	1	1.15	1.56	1.97	2.22	2.46	2.72	3.02	3.32
	2	1.54	2.08	2.69	3.13	3.48	3.86	4.27	4.69
	3	1.81	2.48	3.23	3.66	4.12	4.73	5.22	5.74
EVR 22	1	1.38	1.87	2.36	2.66	2.95	3.27	3.62	3.98
	2	1.85	2.50	3.23	3.76	4.18	4.63	5.12	5.63
	3	2.17	2.97	3.88	4.39	4.94	5.67	6.26	6.89
EVR 25	1	2.30	3.12	3.94	4.43	4.92	5.45	6.04	6.63
	2	3.09	4.17	5.38	6.27	6.96	7.71	8.53	9.39
	3	3.61	4.96	6.47	7.32	8.24	9.45	10.4	11.5
EVR 32	1	3.68	4.99	6.30	7.09	7.88	8.72	9.66	10.6
	2	4.94	6.67	8.61	10.0	11.1	12.3	13.6	15.0
	3	5.78	7.93	10.4	11.7	13.2	15.1	16.7	18.4
EVR 40	1	5.74	7.80	9.85	11.1	12.3	13.6	16.1	16.6
	2	7.71	10.4	13.5	15.7	17.4	19.3	21.3	23.5
	3	9.03	12.4	16.2	18.3	20.6	23.6	26.1	28.7

Metric conversions  
 1 psi = 0.07 bar  
 $\frac{5}{9}(t_1 \text{ } ^\circ\text{F} - 32) = t_2 \text{ } ^\circ\text{C}$   
 1 TR = 3.5 kW

Correction factors

When liquid temperature  $t_l$  ahead of the expansion valve is other than 100 °F, adjust the table capacities by multiplying them by the appropriate correction factor found in the following table.

The table values refer to evaporator capacity and are given as a function of evaporating temperature  $t_e$  and pressure drop  $\Delta p$  across the valve. Capacities are based on liquid temperature  $t_l = 100$  °F ahead of the expansion valve and superheat  $t_s = 7$  °F. For each additional 10 °F of superheat, the table capacities must be reduced by 2%.

Correction factors for liquid temperature  $t_l$

$t_l$ [°F]	80	90	100	110	120
Factor	1.10	1.05	1.00	0.95	0.90

**Capacity  
Suction vapor**  
(continued)

Type	Pressure drop across valve $\Delta p$ [psi]	Suction vapor capacity $Q_0$ [TR] at evaporating temperature $t_e$ [°F]							
		-40	-20	0	10	20	30	40	50
<b>R134a</b>									
EVR 2	1	0.02	0.03	0.05	0.05	0.06	0.07	0.07	0.08
	2	0.03	0.04	0.06	0.07	0.08	0.09	0.11	0.12
	3	0.03	0.05	0.07	0.08	0.10	0.11	0.12	0.14
EVR 3	1	0.04	0.06	0.08	0.09	0.10	0.12	0.13	0.14
	2	0.05	0.08	0.10	0.12	0.14	0.16	0.18	0.21
	3	0.06	0.09	0.12	0.14	0.17	0.19	0.22	0.25
EVR 4	1	0.08	0.11	0.16	0.18	0.21	0.24	0.26	0.30
	2	0.10	0.15	0.21	0.25	0.28	0.33	0.37	0.42
	3	0.11	0.18	0.25	0.30	0.34	0.39	0.44	0.51
EVR 6	1	0.11	0.16	0.23	0.26	0.29	0.33	0.37	0.42
	2	0.14	0.22	0.30	0.35	0.40	0.47	0.53	0.59
	3	0.16	0.25	0.35	0.42	0.48	0.55	0.62	0.72
EVR 8	1	0.16	0.22	0.31	0.35	0.40	0.45	0.51	0.57
	2	0.20	0.30	0.41	0.48	0.55	0.64	0.72	0.81
	3	0.22	0.34	0.49	0.57	0.65	0.75	0.85	0.99
EVR 10	1	0.27	0.38	0.54	0.61	0.69	0.79	0.88	0.99
	2	0.34	0.51	0.71	0.82	0.94	1.11	1.25	1.40
	3	0.37	0.59	0.84	0.99	1.13	1.30	1.47	1.71
EVR 15	1	0.37	0.52	0.73	0.84	0.95	1.08	1.20	1.35
	2	0.47	0.70	0.97	1.13	1.29	1.52	1.71	1.91
	3	0.51	0.80	1.15	1.35	1.54	1.78	2.01	2.34
EVR 18	1	0.48	0.68	0.95	1.09	1.23	1.40	1.56	1.75
	2	0.61	0.91	1.26	1.46	1.68	1.98	2.22	2.49
	3	0.67	1.04	1.50	1.75	2.01	2.31	2.62	3.04
EVR 20	1	0.71	1.00	1.41	1.61	1.82	2.07	2.31	2.59
	2	0.90	1.35	1.87	2.17	2.48	2.92	3.28	3.68
	3	0.98	1.54	2.22	2.59	2.97	3.41	3.87	4.50
EVR 22	1	0.85	1.20	1.69	1.93	2.19	2.48	2.78	3.11
	2	1.08	1.62	2.25	2.60	2.97	3.51	3.94	4.41
	3	1.18	1.85	2.66	3.11	3.56	4.10	4.65	5.40
EVR 25	1	1.41	2.00	2.82	3.22	3.64	4.14	4.63	5.19
	2	1.81	2.69	3.74	4.33	4.96	5.84	6.56	7.35
	3	1.97	3.09	4.43	5.19	5.94	6.83	7.75	8.99
EVR 32	1	2.26	3.20	4.52	5.15	5.83	6.62	7.40	8.30
	2	2.89	4.31	5.99	6.93	7.93	9.35	10.5	11.8
	3	3.15	4.94	7.09	8.30	9.51	10.9	12.4	14.4
EVR 40	1	3.53	5.01	7.06	8.04	9.11	10.3	11.6	13.0
	2	4.51	6.73	9.35	10.8	12.4	14.6	16.4	18.4
	3	4.92	7.71	11.1	13.0	14.9	17.1	19.4	22.5

*Metric conversions*  
 1 psi = 0.07 bar  
 $\frac{5}{9}(t_1 \text{ } ^\circ\text{F} - 32) = t_2 \text{ } ^\circ\text{C}$   
 1 TR = 3.5 kW

*Correction factors*

When liquid temperature  $t_l$  ahead of the expansion valve is other than 100 °F, adjust the table capacities by multiplying them by the appropriate correction factor found in the following table.

The table values refer to evaporator capacity and are given as a function of evaporating temperature  $t_e$  and pressure drop  $\Delta p$  across the valve. Capacities are based on liquid temperature  $t_l = 100$  °F ahead of the expansion valve and superheat  $t_s = 7$  °F.

For each additional 10 °F of superheat, the table capacities must be reduced by 2%.

*Correction factors for liquid temperature  $t_l$*

$t_l$ [°F]	80	90	100	110	120
Factor	1.10	1.05	1.00	0.95	0.90

**Capacity  
Suction vapor**  
(continued)

Type	Pressure drop across valve $\Delta p$ [psi]	Suction vapor capacity $Q_0$ [TR] at evaporating temperature $t_e$ [°F]							
		-40	-20	0	10	20	30	40	50
<b>R404A and R507</b>									
EVR 2	1	0.03	0.04	0.05	0.06	0.07	0.08	0.09	0.10
	2	0.04	0.05	0.08	0.09	0.10	0.11	0.12	0.13
	3	0.05	0.06	0.09	0.10	0.12	0.13	0.15	0.16
EVR 3	1	0.05	0.07	0.09	0.11	0.12	0.13	0.15	0.17
	2	0.07	0.09	0.13	0.15	0.17	0.19	0.21	0.23
	3	0.08	0.11	0.15	0.18	0.20	0.23	0.26	0.29
EVR 4	1	0.10	0.14	0.19	0.22	0.24	0.27	0.30	0.34
	2	0.14	0.19	0.27	0.30	0.34	0.39	0.43	0.48
	3	0.16	0.23	0.31	0.36	0.42	0.47	0.53	0.59
EVR 6	1	0.14	0.20	0.26	0.30	0.34	0.38	0.43	0.48
	2	0.20	0.27	0.38	0.43	0.48	0.54	0.60	0.67
	3	0.23	0.32	0.44	0.50	0.59	0.66	0.74	0.82
EVR 8	1	0.20	0.27	0.36	0.42	0.47	0.52	0.58	0.65
	2	0.27	0.37	0.52	0.58	0.66	0.74	0.83	0.92
	3	0.32	0.44	0.60	0.69	0.80	0.91	1.01	1.13
EVR 10	1	0.34	0.47	0.62	0.72	0.80	0.90	1.01	1.13
	2	0.47	0.64	0.89	1.01	1.14	1.28	1.43	1.60
	3	0.55	0.77	1.04	1.20	1.39	1.57	1.75	1.96
EVR 15	1	0.47	0.65	0.85	0.99	1.10	1.24	1.38	1.54
	2	0.64	0.88	1.22	1.38	1.55	1.76	1.95	2.18
	3	0.75	1.05	1.43	1.64	1.90	2.15	2.40	2.68
EVR 18	1	0.61	0.84	1.11	1.29	1.43	1.61	1.80	2.01
	2	0.83	1.14	1.59	1.80	2.02	2.29	2.54	2.84
	3	0.98	1.36	1.85	2.13	2.47	2.80	3.12	3.48
EVR 20	1	0.90	1.25	1.64	1.90	2.12	2.38	2.66	2.97
	2	1.23	1.69	2.35	2.66	2.99	3.38	3.76	4.20
	3	1.44	2.02	2.74	3.15	3.66	4.14	4.61	5.15
EVR 22	1	1.08	1.50	1.97	2.28	2.54	2.86	3.19	3.56
	2	1.48	2.03	2.82	3.19	3.58	4.06	4.51	5.04
	3	1.73	2.42	3.29	3.78	4.39	4.96	5.53	6.18
EVR 25	1	1.81	2.49	3.28	3.81	4.23	4.76	5.32	5.94
	2	2.46	3.38	4.69	5.32	5.97	6.76	7.52	8.40
	3	2.89	4.04	5.48	6.30	7.32	8.27	9.22	10.31
EVR 32	1	2.89	3.99	5.25	6.09	6.77	7.62	8.51	9.51
	2	3.94	5.41	7.51	8.51	9.56	10.8	12.0	13.4
	3	4.62	6.46	8.77	10.1	11.7	13.2	14.8	16.5
EVR 40	1	4.51	6.24	8.21	9.5	10.6	11.9	13.3	14.9
	2	6.15	8.45	11.7	13.3	14.9	16.9	18.8	21.0
	3	7.22	10.1	13.7	15.8	18.3	20.7	23.1	25.8

*Metric conversions*  
 1 psi = 0.07 bar  
 $\frac{5}{9}(t_1 \text{ } ^\circ\text{F} - 32) = t_2 \text{ } ^\circ\text{C}$   
 1 TR = 3.5 kW

*Correction factors*

When liquid temperature  $t_l$  ahead of the expansion valve is other than 100 °F, adjust the table capacities by multiplying them by the appropriate correction factor found in the following table.

The table values refer to evaporator capacity and are given as a function of evaporating temperature  $t_e$  and pressure drop  $\Delta p$  across the valve. Capacities are based on liquid temperature  $t_l = 100$  °F ahead of the expansion valve and superheat  $t_s = 7$  °F. For each additional 10 °F of superheat, the table capacities must be reduced by 2%.

*Correction factors for liquid temperature  $t_l$*

$t_l$ [°F]	80	90	100	110	120
Factor	1.10	1.05	1.00	0.90	0.90

Capacity  
Hot gas

EVR 2 – 6

Type	Pressure drop across valve $\Delta p$ [psi]	Hot gas capacity $Q_h$ [TR]								
		Evaporating temp. $t_e = 40^\circ\text{F}$ , hot gas temp. $t_h = t_c + 40^\circ\text{F}$ , subcooling $\Delta t_u = 10^\circ\text{F}$								
		R22/R407C			R134a			R404A/R507		
		Condensing temp. $t_c$ [ $^\circ\text{F}$ ]			Condensing temp. $t_c$ [ $^\circ\text{F}$ ]			Condensing temp. $t_c$ [ $^\circ\text{F}$ ]		
		70	100	140	70	100	140	70	100	140
EVR 2	2	0.20	<b>0.22</b>	0.23	0.16	<b>0.18</b>	0.18	0.17	<b>0.17</b>	0.17
	5	0.31	0.35	0.37	0.26	0.28	0.29	0.27	0.28	0.27
	10	0.43	0.49	0.53	0.35	0.39	0.42	0.37	0.40	0.38
	15	0.53	0.58	0.65	0.43	0.48	0.52	0.45	0.47	0.47
	20	0.60	0.67	0.73	0.50	0.56	0.59	0.52	0.54	0.53
	25	0.67	0.75	0.81	0.56	0.63	0.66	0.58	0.61	0.59
EVR 3	2	0.34	<b>0.38</b>	0.41	0.28	<b>0.31</b>	0.32	0.29	<b>0.30</b>	0.29
	5	0.55	0.60	0.64	0.45	0.49	0.51	0.47	0.48	0.47
	10	0.75	0.86	0.92	0.62	0.69	0.74	0.64	0.70	0.67
	15	0.92	1.02	1.14	0.76	0.84	0.91	0.79	0.82	0.82
	20	1.05	1.18	1.27	0.88	0.97	1.03	0.90	0.94	0.92
	25	1.18	1.31	1.42	0.99	1.09	1.15	1.02	1.06	1.03
EVR 4	2	0.70	<b>0.77</b>	0.83	0.57	<b>0.63</b>	0.66	0.59	<b>0.62</b>	0.60
	5	1.12	1.23	1.32	0.92	1.01	1.05	0.95	0.99	0.95
	10	1.54	1.76	1.88	1.26	1.40	1.50	1.30	1.42	1.36
	15	1.87	2.08	2.32	1.54	1.72	1.87	1.60	1.67	1.68
	20	2.15	2.40	2.59	1.79	1.99	2.10	1.85	1.93	1.88
	25	2.40	2.67	2.89	2.01	2.23	2.35	2.07	2.17	2.09
EVR 6	2	0.98	<b>1.08</b>	1.16	0.80	<b>0.88</b>	0.92	0.83	<b>0.87</b>	0.84
	5	1.57	1.73	1.85	1.29	1.41	1.47	1.33	1.39	1.34
	10	2.16	2.47	2.63	1.77	1.96	2.11	1.83	1.99	1.91
	15	2.63	2.92	3.26	2.17	2.41	2.62	2.25	2.35	2.36
	20	3.02	3.37	3.64	2.51	2.79	2.94	2.59	2.70	2.63
	25	3.37	3.75	4.06	2.82	3.13	3.30	2.91	3.04	2.94

**Note:**  
Bold figures refer to rated capacity

Metric conversions  
1 psi = 0.07 bar  
 $\frac{5}{9}(t_1^\circ\text{F} - 32) = t_2^\circ\text{C}$   
1 TR = 3.5 kW

Correction factors

The table values refer to hot gas capacity and are given as a function of condensing temperature  $t_c$  and pressure drop  $\Delta p$  across the valve. Capacities are based on a hot gas temperature superheated  $40^\circ\text{F}$  above condensing temperature ( $t_h = t_c + 40^\circ\text{F}$ ). For each additional  $10^\circ\text{F}$  of superheat above  $40^\circ\text{F}$ , the table capacities must be reduced by 1%.

When the valve is used in a hot gas defrost circuit, evaporator temperature affects the capacity. When the evaporator temperature differs from  $40^\circ\text{F}$ , adjust the table capacities by multiplying them by the appropriate correction factor found in the following table.

Correction factors for  $t_h$  and  $t_e$

$t_e$ [ $^\circ\text{F}$ ]	-40	-20	0	20	40	50
Factor	1.18	1.14	1.09	1.04	1	0.97

**Capacity  
Hot gas**  
(continued)

EVR 8 – 18

Type	Pressure drop across valve $\Delta p$ [psi]	Hot gas capacity $Q_h$ [TR]								
		Evaporating temp. $t_e = 40^\circ\text{F}$ , hot gas temp. $t_h = t_c + 40^\circ\text{F}$ , subcooling $\Delta t_u = 10^\circ\text{F}$								
		R22/R407C			R134a			R404A/R507		
		Condensing temp. $t_c$ [°F]			Condensing temp. $t_c$ [°F]			Condensing temp. $t_c$ [°F]		
	70	100	140	70	100	140	70	100	140	
EVR 8	2	1.35	<b>1.49</b>	1.60	1.10	<b>1.21</b>	1.27	1.14	<b>1.19</b>	1.16
	5	2.15	2.37	2.54	1.78	1.94	2.03	1.83	1.91	1.84
	10	2.97	3.40	3.62	2.43	2.70	2.90	2.52	2.74	2.62
	15	3.61	4.01	4.48	2.98	3.31	3.60	3.09	3.23	3.25
	20	4.15	4.62	5.00	3.45	3.83	4.05	3.56	3.71	3.62
	25	4.63	5.16	5.58	3.88	4.30	4.54	4.00	4.18	4.04
EVR 10	2	2.33	<b>2.57</b>	2.76	1.90	<b>2.10</b>	2.20	1.98	<b>2.06</b>	2.00
	5	3.72	4.10	4.38	3.07	3.36	3.50	3.16	3.29	3.17
	10	5.13	5.87	6.26	4.20	4.66	5.01	4.35	4.73	4.53
	15	6.24	6.93	7.74	5.15	5.72	6.22	5.34	5.58	5.61
	20	7.17	7.99	8.63	5.96	6.62	6.99	6.15	6.42	6.26
	25	8.00	8.91	9.64	6.70	7.43	7.85	6.90	7.22	6.98
EVR 15	2	3.18	<b>3.52</b>	3.77	2.60	<b>2.87</b>	3.00	2.71	<b>2.82</b>	2.73
	5	5.09	5.61	6.00	4.20	4.59	4.79	4.33	4.51	4.34
	10	7.02	8.04	8.56	5.74	6.38	6.85	5.95	6.47	6.20
	15	8.54	9.48	10.6	7.04	7.83	8.51	7.31	7.63	7.67
	20	9.81	10.9	11.8	8.16	9.06	9.57	8.41	8.78	8.56
	25	10.9	12.2	13.2	9.2	10.2	10.7	9.45	9.88	9.55
EVR 18	2	4.14	<b>4.57</b>	4.90	3.38	<b>3.73</b>	3.91	3.52	<b>3.67</b>	3.55
	5	6.62	7.29	7.80	5.46	5.97	6.22	5.63	5.86	5.65
	10	9.13	10.5	11.1	7.47	8.29	8.91	7.73	8.41	8.07
	15	11.1	12.3	13.8	9.15	10.2	11.1	9.51	9.92	9.98
	20	12.8	14.2	15.4	10.6	11.8	12.4	10.9	11.4	11.1
	25	14.2	15.9	17.2	11.9	13.2	14.0	12.3	12.9	12.4

**Note:**  
Bold figures refer to rated capacity

*Metric conversions*  
1 psi = 0.07 bar  
 $\frac{5}{9}(t_1^\circ\text{F} - 32) = t_2^\circ\text{C}$   
1 TR = 3.5 kW

*Correction factors*

The table values refer to hot gas capacity and are given as a function of condensing temperature  $t_c$  and pressure drop  $\Delta p$  across the valve. Capacities are based on a hot gas temperature superheated  $40^\circ\text{F}$  above condensing temperature ( $t_h = t_c + 40^\circ\text{F}$ ). For each additional  $10^\circ\text{F}$  of superheat above  $40^\circ\text{F}$ , the table capacities must be reduced by 1%.

When the valve is used in a hot gas defrost circuit, evaporator temperature affects the capacity. When the evaporator temperature differs from  $40^\circ\text{F}$ , adjust the table capacities by multiplying them by the appropriate correction factor found in the following table.

*Correction factors for  $t_h$  and  $t_e$*

$t_e$ [°F]	-40	-20	0	20	40	50
Factor	1.18	1.14	1.09	1.04	1	0.97

**Capacity  
Hot gas**  
(continued)

EVR 20 – 40

Type	Pressure drop across valve $\Delta p$ [psi]	Hot gas capacity $Q_h$ [TR]								
		Evaporating temp. $t_e = 40^\circ\text{F}$ , hot gas temp. $t_h = t_e + 40^\circ\text{F}$ , subcooling $\Delta t_u = 10^\circ\text{F}$								
		R22/R407C			R134a			R404A/R507		
		Condensing temp. $t_c$ [ $^\circ\text{F}$ ]			Condensing temp. $t_c$ [ $^\circ\text{F}$ ]			Condensing temp. $t_c$ [ $^\circ\text{F}$ ]		
	70	100	140	70	100	140	70	100	140	
EVR 20	2	6.12	6.76	7.25	5.01	5.51	5.78	5.20	5.43	5.25
	5	9.80	10.8	11.5	8.07	8.83	9.21	8.32	8.67	8.35
	10	13.5	15.5	16.5	11.1	12.3	13.2	11.4	12.4	11.9
	15	16.4	18.2	20.4	13.5	15.1	16.4	14.1	14.7	14.8
	20	18.9	21.0	22.7	15.7	17.4	18.4	16.2	16.9	16.5
	25	21.0	23.5	25.4	17.6	19.6	20.7	18.2	19.0	18.4
EVR 22	2	7.35	8.11	8.71	6.01	6.62	6.93	6.24	6.52	6.30
	5	11.8	12.9	13.9	9.69	10.6	11.1	9.99	10.4	10.0
	10	16.2	18.6	19.8	13.3	14.7	15.8	13.7	14.9	14.3
	15	19.7	21.9	24.4	16.3	18.1	19.6	16.9	17.6	17.7
	20	22.7	25.2	27.3	18.8	20.9	22.1	19.4	20.3	19.8
	25	25.3	28.1	30.5	21.2	23.5	24.8	21.8	22.8	22.0
EVR 25	2	12.2	13.5	14.5	10.0	11.0	11.6	10.4	10.9	10.5
	5	19.6	21.6	23.1	16.2	17.7	18.4	16.6	17.3	16.7
	10	27.0	30.9	32.9	22.1	24.5	26.4	22.9	24.9	23.9
	15	32.9	36.5	40.7	27.1	30.1	32.7	28.1	29.4	29.5
	20	37.8	42.1	45.4	31.4	34.9	36.8	32.4	33.8	32.9
	25	42.1	46.9	50.8	35.3	39.1	41.3	36.3	38.0	36.7
EVR 32	2	19.6	21.6	23.2	16.0	17.7	18.5	16.7	17.4	16.8
	5	31.4	34.5	36.9	25.8	28.3	29.5	26.6	27.7	26.7
	10	43.2	49.5	52.7	35.3	39.2	42.2	36.6	39.8	28.2
	15	52.6	58.4	65.2	43.3	48.2	52.4	45.0	47.0	47.2
	20	60.4	67.3	72.7	50.2	55.8	58.9	51.8	54.0	52.7
	25	67.3	75.1	81.2	56.4	62.6	66.1	58.1	60.3	58.8
EVR 40	2	30.6	33.8	36.3	25.0	27.6	28.9	26.0	27.2	26.3
	5	49.0	53.9	57.7	40.4	44.2	46.0	41.6	43.3	41.8
	10	67.5	77.3	82.3	55.2	61.3	65.9	57.2	62.2	59.7
	15	82.1	91.1	101.0	67.7	75.3	81.8	70.3	73.4	73.8
	20	94.4	105.0	113.0	78.5	87.2	92.0	80.9	84.4	82.3
	25	105.0	117.0	126.0	88.1	97.8	103.0	90.8	95.0	91.8

*Metric conversions*  
 1 psi = 0.07 bar  
 $\frac{5}{9} (t_1^\circ\text{F} - 32) = t_2^\circ\text{C}$   
 1 TR = 3.5 kW

**Correction factors**

The table values refer to hot gas capacity and are given as a function of condensing temperature  $t_c$  and pressure drop  $\Delta p$  across the valve. Capacities are based on a hot gas temperature superheated 40 °F above condensing temperature ( $t_h = t_c + 40^\circ\text{F}$ ). For each additional 10 °F of superheat above 40 °F, the table capacities must be reduced by 1%.

When the valve is used in a hot gas defrost circuit, evaporator temperature affects the capacity. When the evaporator temperature differs from 40 °F, adjust the table capacities by multiplying them by the appropriate correction factor found in the following table.

**Correction factors for  $t_h$  and  $t_e$**

$t_c$ [ $^\circ\text{F}$ ]	-40	-20	0	20	40	50
Factor	1.18	1.14	1.09	1.04	1	0.97

Identification

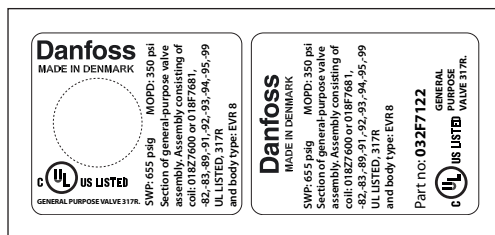

Example

EVR 8	Valve type and size
SWP	Safe Working Pressure (MWP) in psig
018Z7600	Coil group for the EVR
MOPD	Maximum Operating Pressure in psi
S and A	Approvals in USA and Canada

Essential valve data is given on the label

Valve selection example

Note:

When selecting the appropriate solenoid valve, it is easier to convert the actual required capacity to that of the rated capacities listed in the tables.

This is done by utilizing various correction factors in the selection process. The following examples illustrate how this is done.

Metric conversions

1 psi = 0.07 bar  
 $\frac{5}{9}(t_1 \text{ } ^\circ\text{F} - 32) = t_2 \text{ } ^\circ\text{C}$   
 1 TR = 3.5 kW

Liquid line solenoid valve selection example

Refrigerant R134a  
 Condensing temperature  $t_c = 100 \text{ } ^\circ\text{F}$   
 Liquid temperature ahead of valve  $t_l = 90 \text{ } ^\circ\text{F}$   
 Maximum allowable pressure drop across valve  $\Delta p = 2 \text{ psi}$   
 Evaporator capacity  $Q_o = 10 \text{ TR}$  (required valve capacity)

Step 1:

Determine the correction factor for liquid temperature. From the correction factor table found on page 7, a liquid temperature of  $90 \text{ } ^\circ\text{F}$  corresponds to a factor of 1.05.

Step 2:

Correct the required valve capacity. This is done by dividing the evaporator capacity by the liquid correction factor.  
 $Q_{\text{corrected}} = 10/1.05 = 9.5 \text{ TR}$

Step 3:

Select the appropriate capacity table and choose the first valve whose capacity is greater than or equal to  $Q_{\text{corrected}}$  at the required pressure drop. Using the R134a liquid capacity table found on page 7, the EVR 10 is selected as it has a capacity of 10.5 TR at a  $\Delta p = 2 \text{ psi}$ .

Suction line solenoid valve selection example

Refrigerant R134a  
 Liquid temperature ahead of expansion valve  $t_l = 90 \text{ } ^\circ\text{F}$   
 Evaporator temperature  $t_e = 30 \text{ } ^\circ\text{F}$   
 Superheat ahead of valve  $t_s = 17 \text{ } ^\circ\text{F}$   
 Maximum allowable pressure drop across valve  $\Delta p = 3 \text{ psi}$   
 Evaporator capacity  $Q_o = 10 \text{ TR}$  (required valve capacity)

Step 1:

Determine the correction factor for superheat ahead of the valve by increasing the required valve capacity by 2% for each  $10 \text{ } ^\circ\text{F}$  of actual superheat above the table rated value of  $7 \text{ } ^\circ\text{F}$ . In the example, a superheat of  $17 \text{ } ^\circ\text{F}$  corresponds to a  $10 \text{ } ^\circ\text{F}$  increase above the table value which is equivalent to a superheat correction factor of 1.02.

Step 2:

Determine the correction factor for liquid temperature. From the correction factor table found on page 9, a liquid temperature of  $90 \text{ } ^\circ\text{F}$  corresponds to a factor of 1.05.

Step 3:

Correct the required valve capacity. This is done by first multiplying the evaporator capacity by the superheat correction factor and then dividing it by the liquid correction factor.  
 $Q_{\text{corrected}} = (10 \times 1.02)/1.05 = 9.7 \text{ TR}$

Step 4:

Select the appropriate capacity table and choose the first valve whose capacity is greater than or equal to  $Q_{\text{corrected}}$  at the required evaporating temperature and pressure drop. Using the R134a suction vapor capacity table found on page 9, the EVR 32 is selected as it has a capacity of 10.9 TR at  $t_e = 30 \text{ } ^\circ\text{F}$  and  $\Delta p = 3 \text{ psi}$ .



**Valve selection example**  
(continued)

*Hot gas line solenoid valve selection example*  
With hot gas defrost, pressure in the evaporator quickly rises to a value near that of the condensing pressure and remains there until the defrost cycle has been completed. Therefore, when selecting valves for hot gas applications, sizing is based primarily on the condensing temperature  $t_c$  and the pressure drop  $D_p$  across the valve.

*Example (with heat recovery)*

Refrigerant: R134a  
Evaporator temperature:  $t_e = 0\text{ }^\circ\text{F}$   
Condensing temperature:  $t_c = 100\text{ }^\circ\text{F}$   
Hot gas temperature ahead of valve:  $t_h = 180\text{ }^\circ\text{F}$   
Maximum allowable pressure drop across valve:  $\Delta p = 5\text{ psi}$   
Output of heat recovery condenser:  $Q_h = 15\text{ TR}$   
(required valve capacity)

*Metric conversions*

1 psi = 0.07 bar  
 $\frac{5}{9}(t_1\text{ }^\circ\text{F} - 32) = t_2\text{ }^\circ\text{C}$   
1 TR = 3.5 kW

**Step 1:**

Determine the correction factor for hot gas temperature ( $t_h = t_c + 40\text{ }^\circ\text{F}$ ) by increasing the required valve capacity by 1% for each 10 °F of actual superheat above the table rated superheat value of 40 °F. In the example, an actual hot gas temperature of 180 °F is 40 °F higher than the calculated table value of ( $t_h = t_c + 40\text{ }^\circ\text{F} = 140\text{ }^\circ\text{F}$ ). This is equivalent to a hot gas correction factor of 1.04 (4% higher).

**Step 2:**

Determine the correction factor for evaporator temperature. From the correction factor table found on page 11, an evaporator temperature of 0 °F corresponds to a factor of 1.09.

**Step 3:**

Correct the required valve capacity. This is done by first multiplying the heat recovery capacity by the hot gas correction factor and then dividing it by the evaporator correction factor.  
 $Q_{\text{corrected}} = (15 \times 1.04) / 1.09 = 14.3\text{ TR}$

**Step 4:**

Select the appropriate capacity table and choose the first valve whose capacity is greater than or equal to  $Q_{\text{corrected}}$  at the required condensing temperature and pressure drop. Using the R134a hot gas capacity table found on pages 11 and 12, the EVR 25 is selected as it has a capacity of 17.7 TR at  $t_c = 100\text{ }^\circ\text{F}$  and  $\Delta p = 5\text{ psi}$ .

Design / Function

EVR 2 and EVR 3, NC

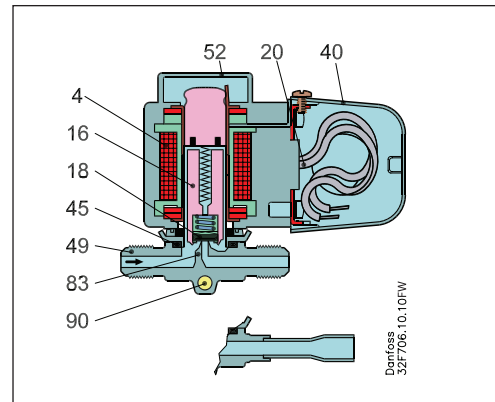

EVR 4 – EVR 22, NC

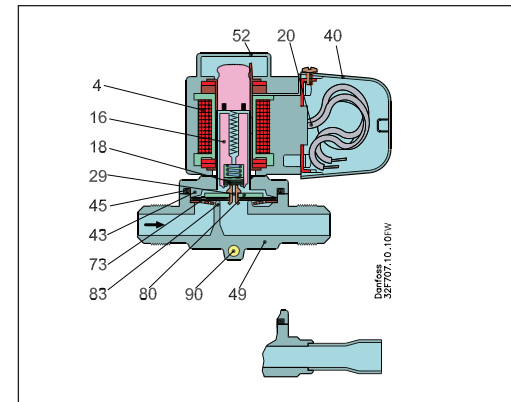

EVR 6 – EVR 15, NO

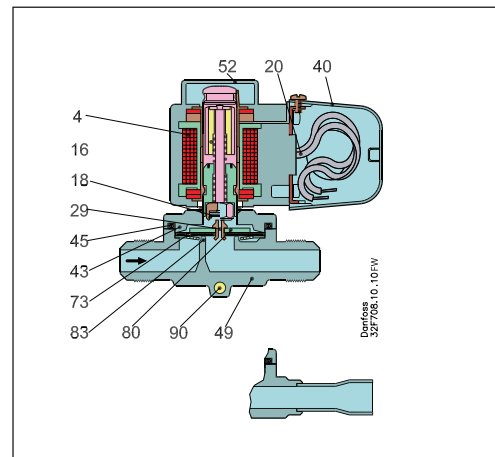

- 4. Coil
- 16. Armature
- 18. Valve plate
- 20. Earth terminal
- 29. Pilot orifice
- 40. Junction box
- 43. Valve cover
- 45. Gasket
- 49. Valve body
- 54. Spacer ring
- 73. Equalizing hole
- 80. Diaphragm
- 83. Valve seat
- 90. Fixing hole

EVR solenoid valves are based on two different design principles:

1. Direct operation
2. Servo operation

*1: Direct operation*

EVR 2 and EVR 3 are direct operated. The valves opens to admit full flow when the armature (16) is moved up into the magnetic field of the coil. The valves operates with a minimum differential pressure of 0 psi.

The valve plate (18) is fitted directly to the armature (16).

Inlet pressure and spring force act to close the valve when the coil is de-energized.

*2a:*

EVR 4 – 22 are servo-operated with a “floating” diaphragm (80). The pilot orifice (29) is located in the center of the diaphragm.

The pilot valve plate (18) is fitted directly to the armature (16).

When the coil is de-energized, the valve port and pilot orifice are closed and the inlet pressure acts both above and below the diaphragm.

The valve port and pilot orifice are kept closed by the armature spring force and the differential pressure between inlet and outlet sides.

When current is applied to the coil, the armature is pulled up into the magnetic field and the pilot orifice opens. This relieves pressure above the diaphragm because the space above it becomes connected to the outlet side of the valve.

The differential pressure between inlet and outlet presses the diaphragm away from the valve seat (83) and the valve opens to admit full flow. A minimum differential pressure (0.7 psi for EVR 4 – 22) is necessary to open the valve and keep it open.

When the coil is de-energized, the pilot orifice closes. Then, via the equalizing port (73) the pressure above the diaphragm rises to the same value as the inlet pressure, which results in the valve port being closed by the diaphragm.

EVR 6 – 15, NO, function in a manner opposite to the NC valves; they are open when the coil is de-energized.

Normally open (NO) EVR valves are available with servo operation only.

Design / Function  
(continued)

EVR 25

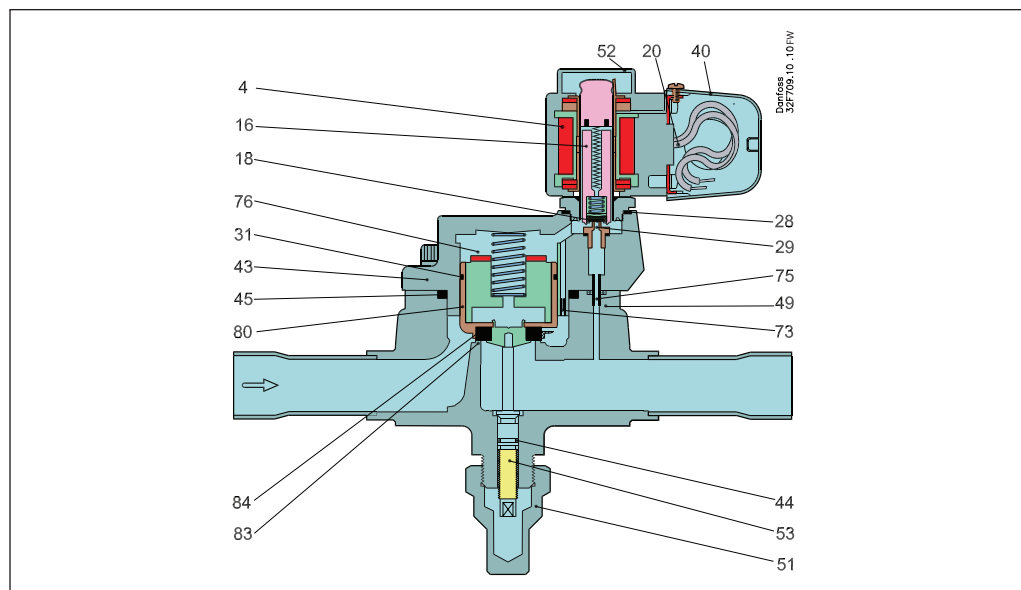

EVR 32 and EVR 40

- 4. Coil
- 16. Armature
- 18. Pilot valve plate
- 20. Earth screw
- 28. Gasket
- 29. Pilot orifice
- 30. O-ring
- 31. Piston ring
- 40. Junction box
- 43. Valve cover
- 44. O-ring
- 45. Valve cover gasket
- 49. Valve body
- 51. Protective cap /blanking plug
- 53. Manual stem
- 73. Equalizing hole
- 74. Main passage
- 75. Pilot passage
- 76. Return spring
- 80. Servo piston
- 83. Main valve seat
- 84. Main valve plate

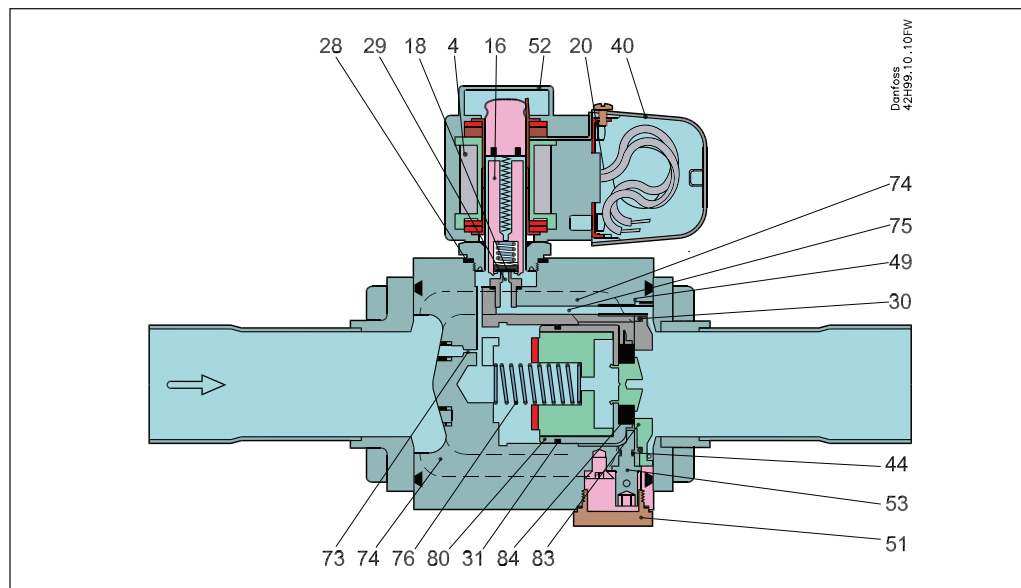

2b. Servo operation of EVR 25 – EVR 40

EVR 25, EVR 32 and EVR 40 are servo-operated piston valves.

The valves are closed when the coil is de-energized. In operation, EVR 25 is the same as for EVR 4 – EVR 22, but the design is different. The pilot unit is located in the cover and the servo unit is a piston (80) with a cast iron piston ring.

For EVR 25 – 40, piston (80) and valve plate (84) will close against the valve seat (83) due to the differential pressure between inlet and outlet plus the force from the return spring (76).

When the coil is energized, the pilot orifice (29) is opened and pressure on the spring side of the piston is relieved. The pressure differential now opens the valve. The minimum differential required to keep the valve fully open is 1 psi.

Dimensions [in.]  
and weights [lbs]

EVR 2 – 10, NC

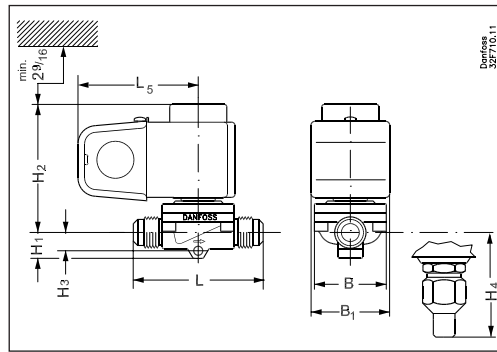

EVR 6, EVR 10 and EVR 15, NO

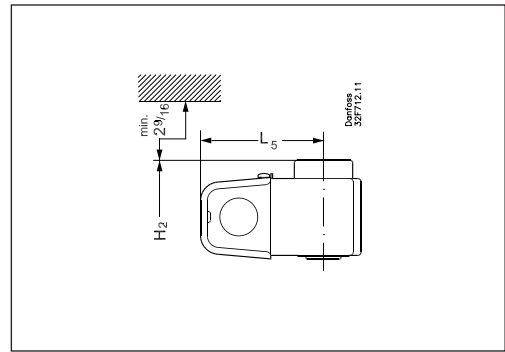

EVR 2 – 22, NC

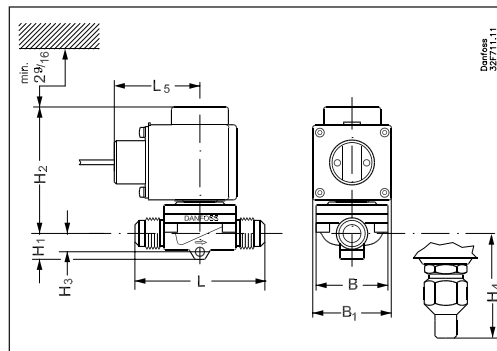

EVR 6, EVR 10 and EVR 15, NO

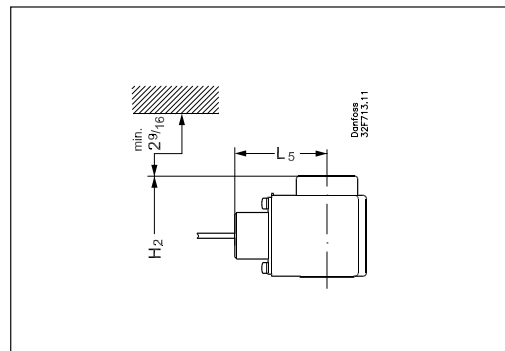

Coil net weight: 1 lb

Flare connection

Type	Connection		L	L <sub>5</sub>	H <sub>1</sub>	H <sub>2</sub> NC	H <sub>3</sub>	H <sub>4</sub>	B	B <sub>1</sub>	Net weight with coil
	normal size	oversize									
EVR 2, NC	1/4	—	2 5/16	2 3/4	9/16	2 13/16	5/16	—	1 5/16	2 1/16	1.3
EVR 3, NC	1/4	—	2 5/16	2 3/4	9/16	2 13/16	5/16	—	1 5/16	2 1/16	1.3
EVR 3, NC	—	3/8	2 7/16	2 3/4	9/16	2 13/16	5/16	—	1 5/16	2 1/16	1.3
EVR 4, NC	3/8	—	2 3/4	2 3/4	9/16	2 7/8	3/8	—	1 7/16	2 1/16	1.4
EVR 4, NC	—	1/2	3	2 3/4	9/16	2 7/8	3/8	—	1 7/16	2 1/16	1.4
EVR 6, NC	3/8	—	2 3/4	2 3/4	9/16	2 7/8	3/8	—	1 7/16	2 1/16	1.4
EVR 6, NC	3/8	—	2 3/4	2 3/4	9/16	2 7/8	—	2 3/16	1 7/16	2 1/16	1.4
EVR 6, NC	—	1/2	3	2 3/4	9/16	2 7/8	3/8	—	1 7/16	2 1/16	1.4
EVR 8, NC	1/2	—	3 5/16	2 3/4	9/16	2 7/8	3/8	—	1 7/16	2 1/16	1.4
EVR 10, NC	1/2	—	3 5/16	2 3/4	9/16	3 1/8	7/16	—	1 13/16	2 1/16	1.8
EVR 10, NC	1/2	—	3 5/16	2 3/4	9/16	3 1/8	—	2 3/16	1 13/16	2 1/16	1.8
EVR 10, NC	—	5/8	3 5/8	2 3/4	9/16	3 1/8	7/16	—	1 13/16	2 1/16	1.8

Metric conversions  
1 in. = 25.4 mm

Dimensions [in.]  
and weights [lbs]

EVR 6 – 15, NO

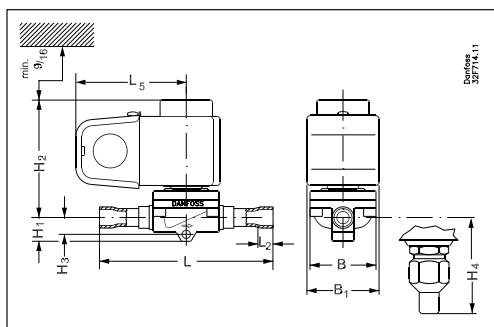

EVR 2 – 22

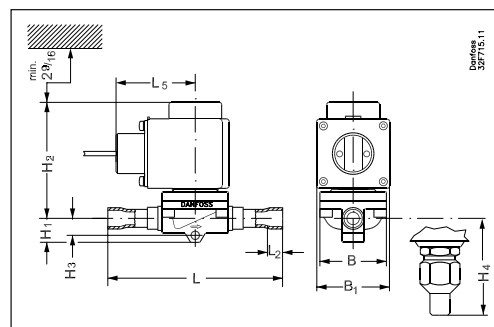

EVR 6 – 15, NO

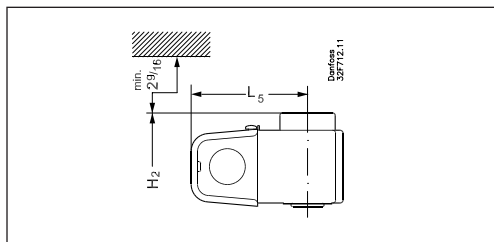

EVR 6 – 15, NO

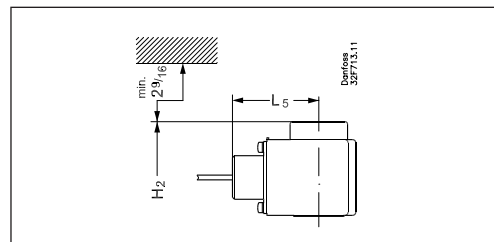

Coil net weight: 1 lb

Solder connection

Type	Connection		L	L <sub>2</sub>	L <sub>5</sub>	H <sub>1</sub>	H <sub>2</sub> NC	H <sub>3</sub>	H <sub>4</sub>	B	B <sub>1</sub>	Net weight with coil
	normal size	oversize										
EVR 2 NC	1/4	—	4 5/8	3/8	2 3/4	9/16	—	5/16	—	1 5/16	2 1/16	1.3
EVR 3 NC	1/4	—	4 5/8	3/8	2 3/4	9/16	2 13/16	5/16	—	1 5/16	2 1/16	1.3
EVR 3 NC	—	3/8	4 5/8	3/8	2 3/4	9/16	2 13/16	5/16	—	1 5/16	2 1/16	1.3
EVR 4 NC	3/8	—	4 3/8	3/8	2 3/4	9/16	3 1/16	3/8	—	1 7/16	2 1/16	1.4
EVR 4 NC	—	1/2	5	3/8	2 3/4	9/16	3 1/16	3/8	—	1 7/16	2 1/16	1.4
EVR 6 NC	3/8	—	4 3/8	3/8	2 3/4	9/16	3 1/16	3/8	—	1 7/16	2 1/16	1.4
EVR 6 NC	3/8	—	4 3/8	3/8	2 3/4	—	3 1/16	—	2 3/16	1 7/16	2 1/16	1.4
EVR 6 NC	—	1/2	5	3/8	2 3/4	9/16	3 1/16	3/8	—	1 7/16	2 1/16	1.4
EVR 6 NC	—	5/8	6 1/2	1/2	2 3/4	9/16	3 1/16	3/8	—	1 7/16	2 1/16	1.4
EVR 8 NC	3/8	—	4 5/8	3/8	2 3/4	9/16	3 1/16	3/8	—	1 7/16	2 1/16	1.4
EVR 8 NC	—	1/2	5	3/8	2 3/4	9/16	3 1/16	3/8	—	1 7/16	2 1/16	1.4
EVR 8 NC	—	5/8	6	1/2	2 3/4	9/16	3 1/16	3/8	—	1 7/16	2 1/16	1.4
EVR 10 NC	3/8	—	4 5/8	3/8	2 3/4	5/8	3 1/8	7/16	—	1 13/16	2 1/16	1.8
EVR 10 NC	—	1/2	5	3/8	2 3/4	5/8	3 1/8	7/16	—	1 13/16	2 1/16	1.8
EVR 10 NC	—	1/2	5	3/8	2 3/4	—	3 1/8	—	2 3/16	1 7/16	2 1/16	1.8
EVR 10 NC	—	5/8	6 5/16	1/2	2 3/4	5/8	3 1/8	7/16	—	1 13/16	2 1/16	1.8
EVR 15 NC	5/8	—	6 7/8	1/2	2 3/4	3/4	3 3/8	3/4	—	2 3/16	2 1/16	2.4
EVR 15 NC	5/8	—	6 7/8	1/2	2 3/4	—	3 3/8	—	2 1/8	2 3/16	2 1/16	2.4
EVR 15 NC	—	7/8	7 1/8	5/8	2 3/4	3/4	3 3/8	3/4	—	2 3/16	2 1/16	2.4
EVR 18 NC	7/8	—	7 1/8	5/8	2 3/4	3/4	3 3/8	3/4	—	2 3/16	2 1/16	2.4
EVR 18 NC	—	1 1/8	8 1/2	7/8	2 3/4	3/4	3 3/8	3/4	—	2 3/16	2 1/16	2.4
EVR 20 NC	7/8	—	7 1/2	5/8	2 3/4	25/32	3 9/16	—	—	2 13/16	2 1/16	3.4
EVR 20 NC	7/8	—	7 1/2	5/8	2 3/4	—	3 9/16	—	2 3/8	2 13/16	2 1/16	3.4
EVR 20 NC	—	1 1/8	8 1/2	7/8	2 3/4	25/32	3 9/16	—	—	2 13/16	2 1/16	3.4
EVR 22 NC	1 1/8	—	10 1/16	7/8	2 3/4	25/32	3 9/16	—	—	2 13/16	2 1/16	3.4
EVR 22 NC	—	1 3/8	11 1/16	1	2 3/4	25/32	3 9/16	—	—	2 13/16	2 1/16	3.4

Metric conversions:  
1 in. = 25.4 mm

Dimensions [in.]  
and weights [lbs]

EVR 25

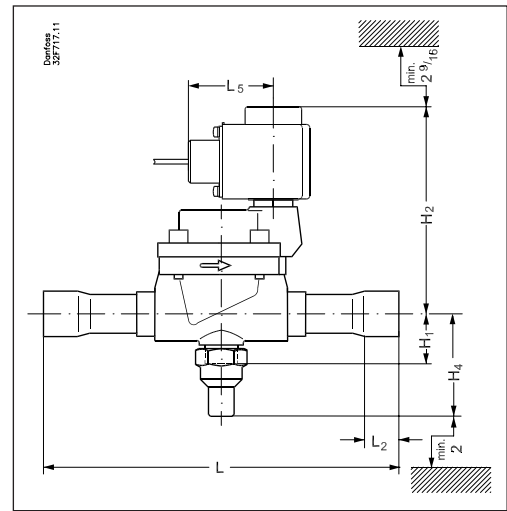
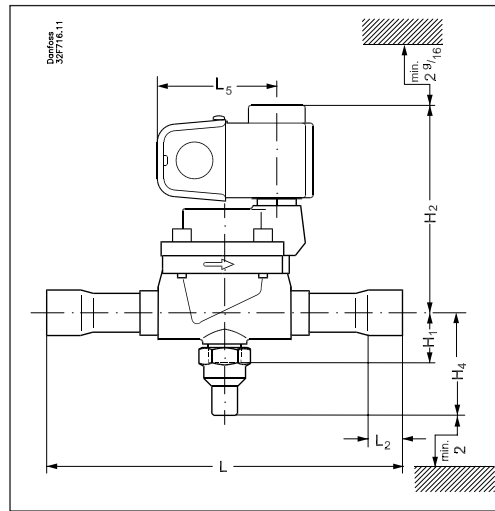

EVR 32 and EVR 40

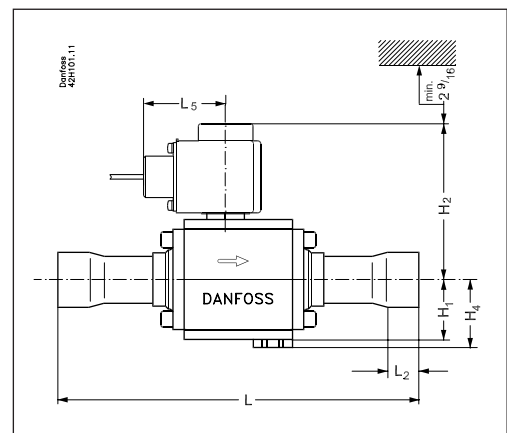
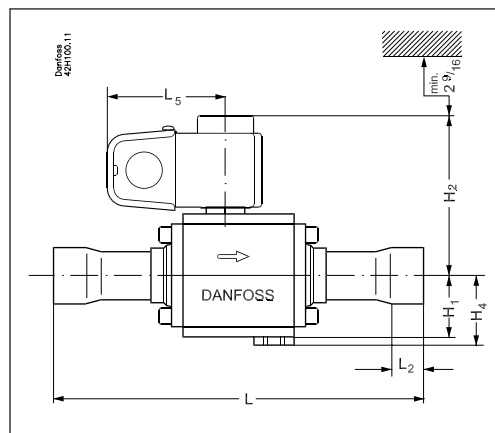

Coil net weight: 1 lb

Solder connection

Type	Connection		L	L <sub>2</sub>	L <sub>5</sub>	H <sub>1</sub>	H <sub>2</sub>	H <sub>4</sub>	B	Net weight with coil
	normal size	oversize								
EVR 25	1 1/8	—	10 1/16	7/8	2 3/8	1 1/2	5 7/16	2 13/16	3 1/4	6.9
EVR 25	—	1 3/8	11 1/16	1	2 3/8	1 1/2	5 7/16	2 13/16	3 1/4	7.7
EVR 32	1 3/8	—	11 1/16	1	2 3/8	1 7/8	4 3/8	2 1/8	3 3/16	9.5
EVR 32	—	1 5/8	11 1/16	1 1/8	2 3/8	1 7/8	4 3/8	2 1/8	3 3/16	9.7
EVR 40	1 5/8	—	11 1/16	1 1/8	2 3/8	1 7/8	4 3/8	2 1/8	3 3/16	10.0
EVR 40	—	2 1/8	11 1/16	1 1/8	2 3/8	1 7/8	4 3/8	2 1/8	3 3/16	10.0

Metric conversions:  
1 in. = 25.4 mm

Spare parts

Type	Code no.			
	Seal kit	Service kit	Piston service kit	Pilot service kit
EVR 2	032F8196	032F0230	—	—
EVR 3	032F8196	032F0230	—	—
EVR 4	032F8165	—	—	—
EVR 6	032F8165	032F8169	—	—
EVR 8	032F8165	032F8169	—	—
EVR 10	032F8196	032F0185	—	—
EVR 15	032F8196	032F0187	—	—
EVR 18	032F8196	032F0187	—	—
EVR 20	—	032F0189	—	—
EVR 22	—	032F0189	—	—
EVR 25	032F3235	—	032F3236	042H0161
EVR 32	042H0160	—	042H0172	042H0165
EVR 40	042H0160	—	042H0173	—
EVR 6 NO	032F8165	—	—	—
EVR 10 NO	032F8196	—	—	—
EVR 15 NO	032F8196	—	—	—

Spare parts, contents

Seal kit	Service kit	Piston service kit	Pilot service kit
O-ring Gasket	Diaphragm assembly Armature assembly Rubber gasket Screws Torx key Snap fastener Nut	Piston assembly Plastic block Spring Piston ring Rubber gasket Snap fastener Nut	Armature tube assembly Snap fastener Armature Orifice Gaskets Nut