



THE HEART OF FRESHNESS

SEMI-HERMETIC

COMPACT SCREW COMPRESSORS

COMPRESSEURS À VIS HERMÉTIQUES ACCESSIBLES COMPACTS

COMPRESORES DE TORNILLO SEMI-HERMÉTICOS COMPACTOS

CSH SERIES 65 // 75 // 85 // 95
SÉRIE CSH 65 // 75 // 85 // 95
SERIE CSH 65 // 75 // 85 // 95

CSH
High Condensing

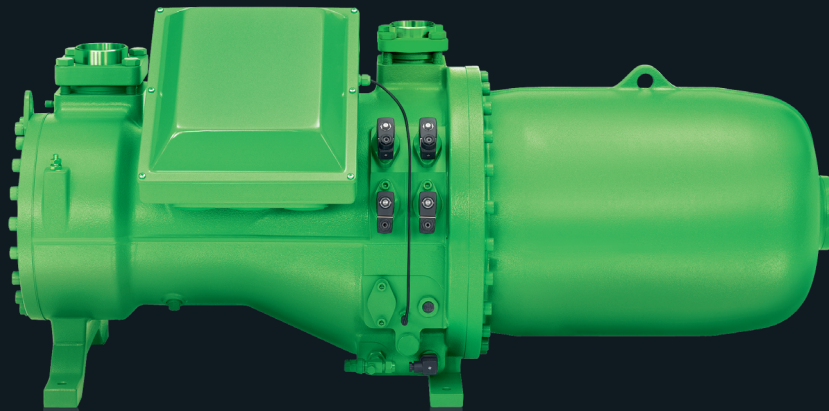

60 Hz // SP-176-2



CSH Series 65 ■ 75 ■ 85 ■ 95

Série CSH 65 ■ 75 ■ 85 ■ 95

Serie CSH 65 ■ 75 ■ 85 ■ 95

Displacements from 5830 to 43261 CFH at 60 Hz

Volumes balayés de 5830 à 43261 CFH (60 Hz)

Volúmenes desplazados de 5830 hasta 43261 CFH a 60 Hz

Content	Page	Sommaire	Page	Contenido	Página
Highlights and technical features	2	Atouts et critères techniques	2	Propiedades y características técnicas	2
Application limits	8	Limites d'application	8	Límites de aplicación	8
Performance data		Données de puissance		Datos de rendimiento	
R134a	10	R134a	10	R134a	10
R22	14	R22	14	R22	14
R407C	18	R407C	18	R407C	18
Technical data	22	Caractéristiques techniques	22	Datos técnicos	22
Dimensional drawings	24	Croquis cotés	24	Dibujos acotados	24

The new "CSH" series is based on the proven construction elements of the innovative BITZER compact screws recognized worldwide as benchmark. They have been specifically developed further with view to their universal application in air-cooled chillers and heat pumps.

In addition to their known attributes, the compressors are distinguished by a further improvement in energy efficiency at full and part load conditions. Moreover, the application limits have been substantially extended towards low condensing temperatures as well as to high pressure ratios (heat pumps) – without compromises regarding operating reliability. Accordingly, these products exceed the international efficiency standard of compact screws with respect to the seasonally weighted energy requirements to an even higher degree than before. This results in particularly high IPLV/ESEER* and SCOP* values.

La nouvelle série «CSH» a été conçue sur la base des éléments de construction éprouvés des vis compactes CSH innovatrices qui se sont imposées comme standard à travers le monde. Ces éléments ont fait l'objet d'un perfectionnement ciblé en vue d'une application universelle dans les groupes refroidisseurs de liquide refroidis à l'air ainsi que dans les pompes à chaleur.

Outre les attributs connus, les compresseurs se distinguent par une efficacité énergétique encore améliorée en pleine charge et en charge partielle. Par ailleurs, les limites d'application en ce qui concerne les basses températures de condensation et les grands rapports de pression (pompes à chaleur) ont été considérablement étendues sans faire de concessions sur la sécurité de fonctionnement. Par rapport au besoin énergétique saisonnièrement pondéré, ces produits dépassent donc, dans une plus large mesure qu'avant, le standard international en matière d'efficacité pour les vis compactes. Il en résulte des valeurs IPLV/ESEER* et SCOP* particulièrement élevées.

La nueva serie "CSH.3" está basada en los elementos de construcción probados de los tornillos compactos CSH innovadores; se consideran el valor de referencia en todo el mundo. Se perfeccionaron específicamente para una aplicación universal en sistemas de enfriamiento por líquido refrigerados por aire así como bombas de calor.

Además de sus propiedades conocidas, los compresores destacan por una eficiencia energética mejorada bajo condiciones de carga plena y parcial. Se ampliaron además considerablemente los límites de utilización tanto con respecto a temperaturas más bajas de condensación como presiones altas (bombas de calor) – sin comprometerse con respecto a la seguridad del proceso. Por eso, estos productos exceden por un grado incluso mayor que hasta ahora el estándar internacional de eficiencia para tornillos compactos con respecto al consumo de energía corregido de variaciones estacionales. De esto resultan valores IPLV/ESEER* y SCOP* particularmente altos.

* IPLV: Integrated Part Load Value (ARI 550/590)
 ESEER: European Seasonal Energy Efficiency Ratio
 SCOP: Seasonal Coefficient of Performance (heat pumps)

* IPLV: Integrated Part Load Value (ARI 550/590)
 ESEER: European Seasonal Energy Efficiency Ratio
 SCOP: Seasonal Coefficient of Performance (pompes à chaleur)

* IPLV: Integrated Part Load Value (ARI 550/590)
 ESEER: European Seasonal Energy Efficiency Ratio
 SCOP: Seasonal Coefficient of Performance (bombas de calor)

These improvements are achieved mainly by the following measures:

- Adaptation of the integrated volume ratio (at full and part load) to the extended application range
- Reduction of the inner flow losses
- Optimization of the oil management system
- Additional cooling for extreme conditions of use through advanced direct refrigerant injection or through external oil cooling with actively controlled oil volume flow.

Ces améliorations ont principalement été réalisées par les mesures suivantes:

- Adaptation du rapport de volume intégré (en pleine charge et en charge partielle) à la gamme étendue d'application
- Réduction de la perte de charge à l'intérieur
- Optimisation du système de gestion d'huile
- Refroidissement additionnel pour les conditions extrêmes d'utilisation à l'aide d'un système perfectionné d'injection de liquide ou par un refroidissement d'huile externe avec un contrôle actif de la quantité d'huile en circulation.

En lo esencial, las medidas siguientes contribuyen a la mejora:

- Adaptación del volumen incorporado (bajo carga plena y parcial) al rango de aplicación ampliado
- Reducción de la pérdida de flujo interior
- Optimización del sistema de gestión de aceite
- Refrigeración adicional para condiciones de uso extremas por medio de una inyección directa de refrigerante o una refrigeración de aceite externa con una cantidad de aceite en circulación activamente controlada.

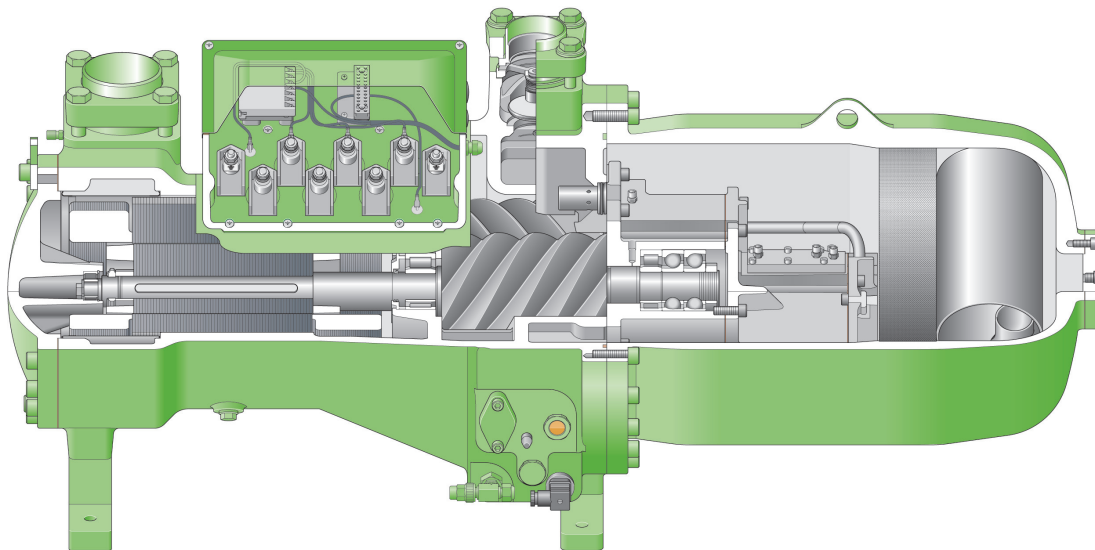

The extension of the application ranges down to lower pressure ratios (at part load) allows the energetic improvement potential through reduced condensing temperatures to be fully used at moderate ambient temperatures.

L'élargissement de la gamme d'applications vers les rapports de pression plus faibles (en charge partielle) permet l'utilisation totale du potentiel d'amélioration énergétique à des températures ambiantes modérées grâce aux basses températures de condensation.

La ampliación de los rangos de utilización para incluir presiones más bajas (bajo carga parcial) permite la utilización completa del potencial de mejora energética con moderadas temperaturas ambiente por medio de temperaturas reducidas de condensación.

In heat pump applications using ambient air as heat source, the new series can be applied at even lower evaporation temperatures while maintaining high condensing temperatures as compared with common compact screws. In Economiser mode, very high efficiencies and an extremely flat performance characteristic are achieved.

Apart from an advanced, easy-to-use, low-cost method for direct refrigerant injection, the compressors can also be operated with an external oil cooler. This operation mode allows even more extreme conditions while being highly efficient. Its special feature is the oil volume flow being adapted especially to oil cooler operation. This is achieved by means of a newly developed control valve flanged to the compressor. The valve is activated electrically on demand. The following figure shows the arrangement of the control valve at the compressor and the oil cooler circuit schematically.

Pour les applications à pompe à chaleur utilisant l'air extérieur comme source de chaleur, les modèles de la nouvelle série, comparés aux vis compactes habituelles, peuvent être utilisés à des températures d'évaporation encore plus basses tout en maintenant des températures de condensation élevées. En mode économiseur, il est possible d'atteindre un rendement particulièrement élevé et une caractéristique de performance très plate.

Outre une méthode évoluée d'injection directe du liquide, un système économique et très facile à utiliser, les compresseurs permettent également l'utilisation d'un refroidisseur d'huile externe. Ce mode de fonctionnement convient aux conditions d'utilisation encore plus extrêmes tout en garantissant une rentabilité élevée. La particularité repose sur une quantité d'huile en circulation spécialement adaptée au fonctionnement avec un refroidisseur d'huile. Cette régulation de la quantité d'huile est assurée par une vanne de régulation fixée par bride sur le compresseur. La vanne est pilotée électriquement en cas de besoin. La figure suivante montre la position de la vanne de régulation sur le compresseur ainsi qu'une représentation schématique du circuit du refroidisseur d'huile.

Si se utiliza el aire exterior como fuente de calor para bombas de calor, la nueva serie de modelos puede utilizarse con temperaturas de evaporación aún más bajas en comparación con los tornillos compactos usuales, utilizando simultáneamente temperaturas de condensación igualmente altas. En funcionamiento con economizador se alcanzan altos rendimientos y una línea característica de la potencia muy plana.

Los compresores pueden operarse con un método perfeccionado, muy simple y económico de una inyección directa del refrigerante o también con un refrigerador de aceite externo. Este funcionamiento permite condiciones de uso incluso más extremas simultáneamente con una alta rentabilidad. Su particularidad es una cantidad de aceite en circulación específicamente adaptada al funcionamiento con refrigerador de aceite; ésta se consigue por medio de una válvula reguladora bridada en el nuevo compresor. La válvula se controla eléctricamente en caso necesario. La siguiente ilustración muestra la posición de la válvula reguladora en el compresor y una representación esquemática del circuito de refrigeración del aceite.

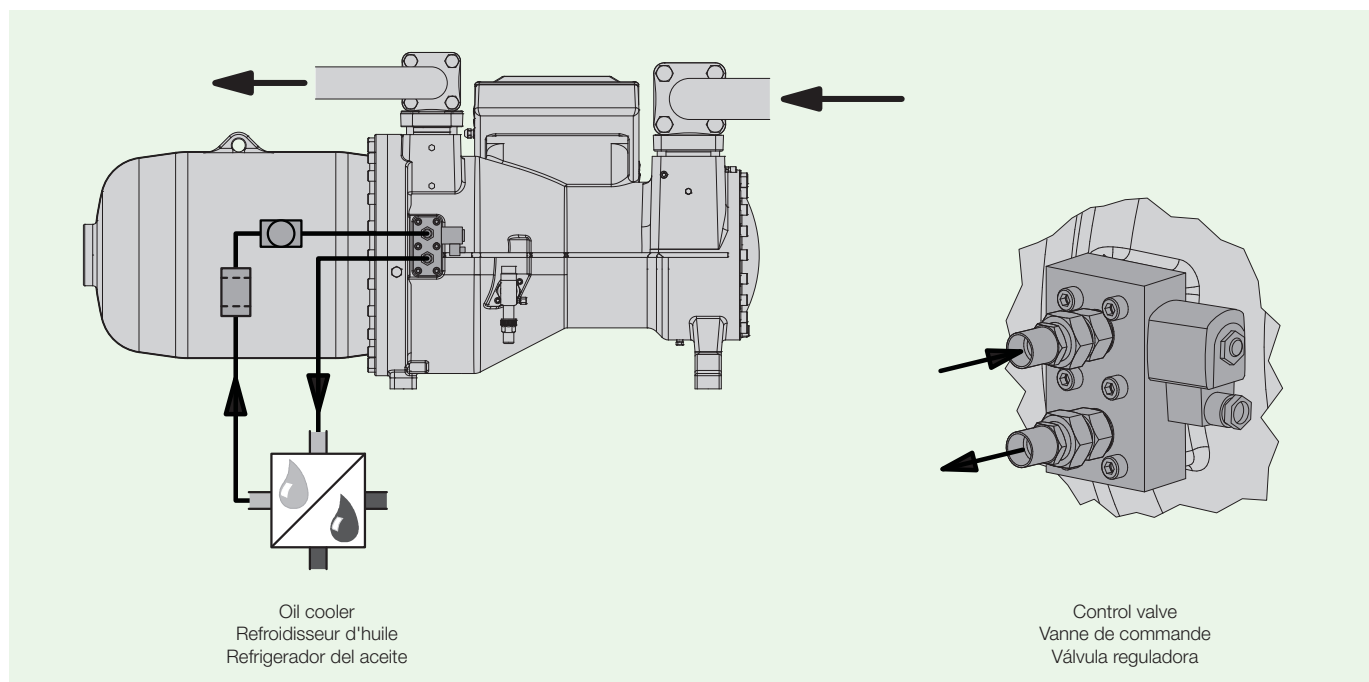

The closely graduated and extensive capacity range

La large gamme de puissance étroitement graduée

Amplia gama de potencias de graduación fina

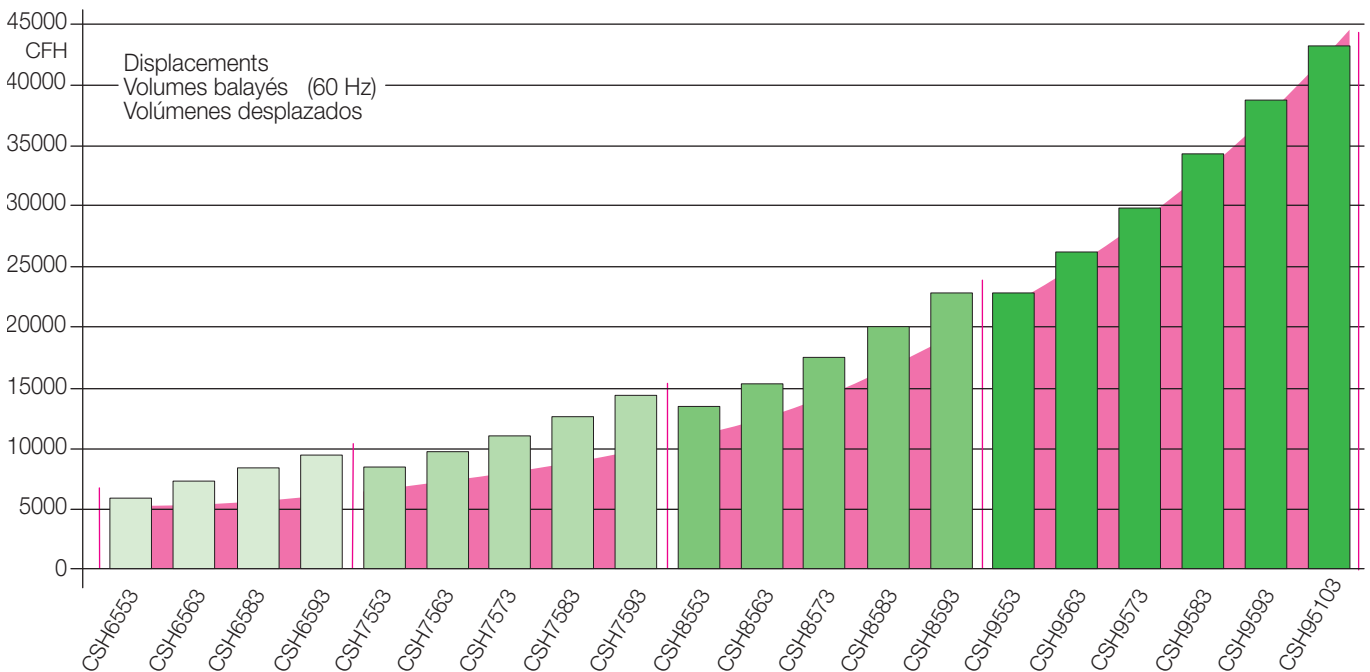

Performance data

Performance data are based on ARI540 standard and 60 Hz operation.

Evaporating and condensing temperatures correspond to "dew point" conditions (saturated vapor).

Reference points for evaporating and condensing pressures

Connection positions 1 (HP) and 3 (LP) on the compressor (see dimensional drawing). The pressure drop for shut-off valves and check valves has not been taken into consideration. This is the worldwide state of the art for compact screws, as in factory-produced chillers shut-off valves are often not used and the check valve can also be arranged as an external component in the discharge line. For the sake of the international comparability of performance data, this standard was also taken over for the screw compressors of the CSH series.

Données de puissance

Les données de puissance se basent sur un fonctionnement à 60 Hz et sur standard ARI540.

Les températures d'évaporation et de condensation se réfèrent aux "valeurs du point de rosée" (conditions de vapeurs saturées).

Points de référence pour les pressions d'évaporation et de condensation

Positions de raccordement 1 (HP) et 3 (LP) sur le compresseur (voir croquis coté). La perte de charge pour vannes d'arrêt et clapets de retenue n'est pas prise en compte. Ceci est mondialement le stade actuel de la technique pour les vis compactes étant donné que pour les groupes frigorifiques réalisés en usine, il est souvent fait abstraction des vannes d'arrêt et que le clapet de retenue peut être monté dans la conduite de refoulement en tant que composant externe. Ce standard a été repris pour les compresseurs à vis de la série CSH en vue d'une comparaison internationale des données de puissance.

Datos de rendimiento

Los datos de rendimiento se basan en standard ARI540 y un funcionamiento a 60 Hz.

En ellos las temperaturas de evaporación y condensación se refieren a "valores del punto de rocío" (condiciones del vapor saturado).

Puntos de referencia para las presiones de evaporación y condensación

Posiciones de conexión 1 (HP) y 3 (HP) en el compresor (véase el dibujo acotado). No se ha contemplado la pérdida de presión en las válvulas de cierre y la válvulas de retención. Este es mundialmente el estado actual de la técnica para los tornillos compactos ya que en los grupos frigoríficos ensamblados en fábrica muchas veces se desiste de usar válvulas de cierre y la válvula de retención puede ser colocada en el conducto de gas comprimido como componente externa. Por tanto, para que los datos del rendimiento sean comparables internacionalmente se aplicó esta norma para los compresores de tornillo de la serie CSH.



Liquid subcooling

For standard operating conditions performance data are based on 15 °F of subcooling.

Economiser operation

Data for economiser operation inherently include liquid subcooling. The liquid temperature is defined as 10 °F above saturated temperature at economiser inlet ($t_{cu} = t_{ms} + 10 \text{ °F}$).

Individual operating points

For detailed compressor selection with the option of individual data input the BITZER Software is available. The resulting output data include all important performance parameters for compressors and additional components, application limits, technical data and dimensional drawings. Moreover, specific data sheets can be generated which may either be printed out, exported as pdf-file or transferred into other software programs, e.g. Excel, for further use.

Sous-refroidissement de liquide

Pour les conditions de fonctionnement standard les données de puissance se basent sur un sous-refroidissement de 15 °F.

Fonctionnement avec économiseur

Pour les données en fonctionnement avec économiseur, un sous-refroidissement est pris en compte (voulu par le système). La température du liquide est définie de 10 °F au-dessus de la température de saturation à l'entrée de l'économiseur ($t_{cu} = t_{ms} + 10 \text{ °F}$).

Points de fonctionnement individuels

Pour une sélection plus précise du compresseur, avec la possibilité d'entrer des données d'entrée individuelles, faire appel au BITZER Software. Les résultats obtenus comprennent tous les paramètres de puissance importants pour le compresseur et les composants annexes, les limites d'application, les données techniques et les croquis cotés. En plus, il est possible de générer des fiches de données spécifiques qui peuvent, soit être exportées comme fichier pdf, soit être imprimées, soit être utilisées comme base de données pour d'autres logiciels (par ex. Excel).

Subenfriamiento de líquidos

Para las condiciones de funcionamiento estándar los datos de rendimiento se basan en un subenfriamiento de 15 °F.

Funcionamiento con economizador

Los datos para el funcionamiento del economizador incluyen – condicionados por el sistema – el subenfriamiento de líquidos. La temperatura del líquido está definida en 10°F por encima de la temperatura de saturación en la entrada del economizador ($t_{cu} = t_{ms} + 10 \text{ °F}$).

Puntos de funcionamiento individuales

Para una selección más precisa del compresor, con la posibilidad de introducir datos individuales, se dispone del BITZER Software. Los datos de salida resultantes comprenden todos los datos importantes relativos al rendimiento del compresor y los componentes adicionales, Los límites de aplicación, los datos técnicos y los dibujos acotados. Además se pueden generar hojas de datos que bien pueden ser impresos, sacados como archivos pdf o exportados como archivos a otros programas (p.e. Excel).

Type designation

Example

CSH 7573 - 90 Y - 40P

Semi-hermetic compact screw compressor

CSH 7573 - 90 Y - 40P

Housing size

CSH 7573 - 90 Y - 40P

Code for displacement (5 .. 11)

CSH 7573 - 90 Y - 40P

Compressor execution (3 = optimized for SEER)

CSH 7573 - 90 Y - 40P

Code for motor size

CSH 7573 - 90 Y - 40P

Oil charge (polyol-ester) for R134a and R407C (R404A/R507A)

CSH 7573 - 90 Y - 40P

Motor code

Designation des types

Exemple

CSH 7573 - 90 Y - 40P

Vis hermétique-accessible compacte

CSH 7573 - 90 Y - 40P

Taille de carter

CSH 7573 - 90 Y - 40P

Code pour volume balayé (5 .. 11)

CSH 7573 - 90 Y - 40P

Exécution du compresseur (3 = optimisé pour SEER)

CSH 7573 - 90 Y - 40P

Code pour taille de moteur

CSH 7573 - 90 Y - 40P

Charge d'huile polyolester, pour R134a et R407C (R404A/R507A)

CSH 7573 - 90 Y - 40P

Code de moteur

Designación de tipos

Ejemplo

CSH 7573 - 90 Y - 40P

Compresor de tornillo semi-hermético compacto

CSH 7573 - 90 Y - 40P

Tamaño del cárter

CSH 7573 - 90 Y - 40P

Código para volumen desplazado (5 .. 11)

CSH 7573 - 90 Y - 40P

Versión de compresor (3 = optimizado para SEER)

CSH 7573 - 90 Y - 40P

Código para tamaño de motor

CSH 7573 - 90 Y - 40P

Carga de aceite (polioléster) para R134a y R407C (R404A/R507A)

CSH 7573 - 90 Y - 40P

Código del motor

Application limits

Limites d'application

Límites de aplicación

R134a Standard

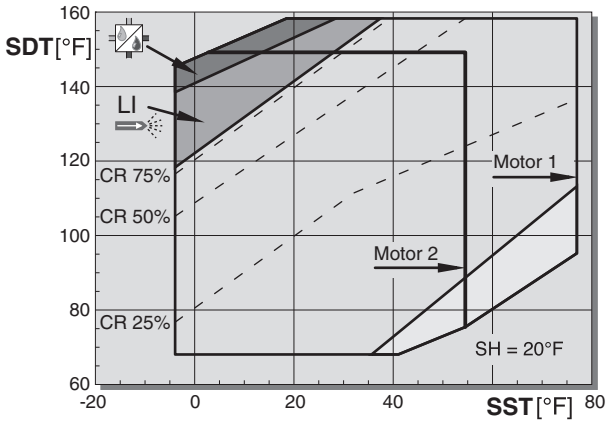

R134a ECO

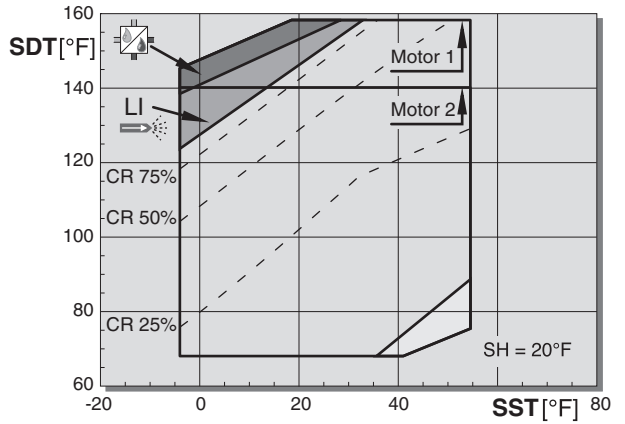

R22 Standard

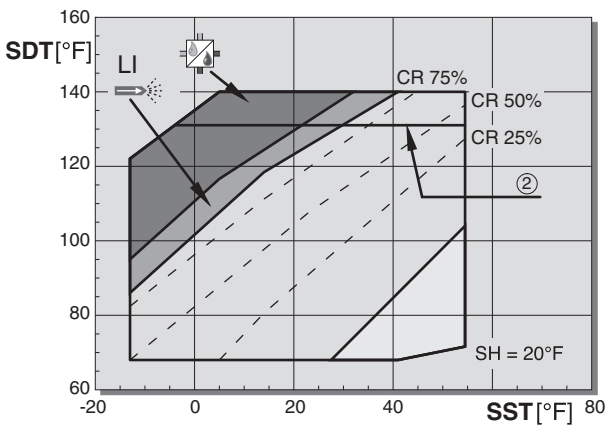

R22 ECO

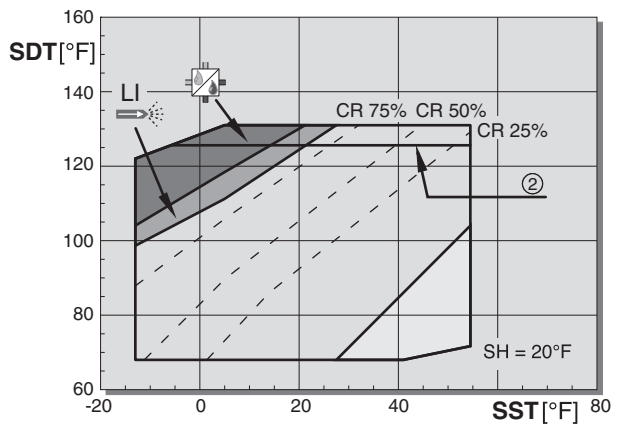

R407C Standard

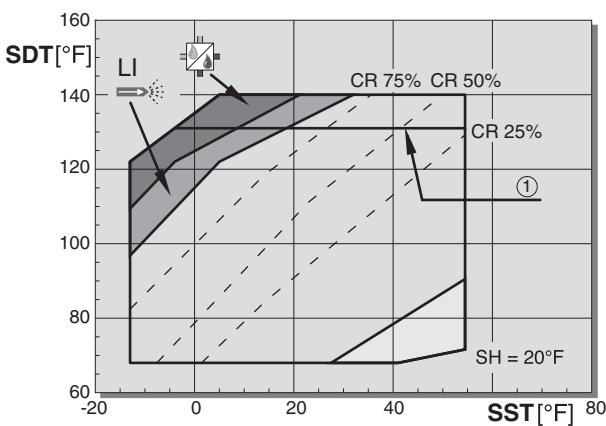

R407C ECO

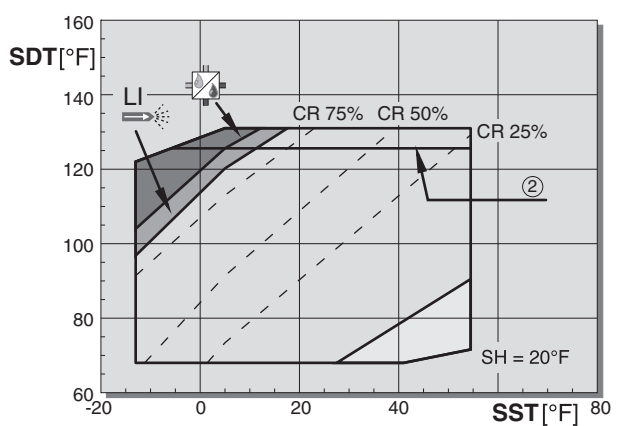

Explanation to application limits

Thermal limits for capacity control (CR) and additional cooling (liquid injection and external oil cooling) depend on the compressor type.

The maximum condensing temperature can be restricted with individual types.

i **Extended application limits** are possible depending on system layout. However, this must be individually co-ordinated with BITZER.

Explication des limites d'application

Les limites thermiques pour la régulation de puissance (CR) et le refroidissement additionnel (injection de liquide et refroidissement d'huile externe) dépendent du type du compresseur.

La température de condensation maximum peut-être limitée pour quelques types.

i **Des limites d'application élargies** sont possible dépendant d'exécution du système. Ceci nécessite cependant une concentration individuelle avec BITZER.

Explicación de los límites de aplicación

Los límites térmicos de la regulación de potencia (CR) y la refrigeración adicional (inyección de refrigerante y refrigeración externa del aceite) no dependen del tipo de compresor.

La temperatura de condensación máxima puede estar limitada para tipos individuales.

i **Límites de aplicación ampliados** son posibles en dependencia del modelo del sistema. No obstante, esto debe ser consultado a BITZER por individual.

Legend

SST Saturated suction temperature (°F)

SH Suction superheat (°F)

SDT Saturated discharge temperature (°F)

■ Compressor capacity max. 75%

■ Liquid injection or external oil cooling required.

For part-load operation the respective application limits (CR 75%, CR 50% and CR 25%) can be lifted with liquid injection by 10 °F in the condensing temperature, however at maximum up to the full-load limits.

■ External oil cooling required

① Maximum saturated discharge temperature with CSH8583, CSH8593, CSH9593 and CSH95103

② Maximum saturated discharge temperature with CSH8583, CSH8593, CSH9583, CSH9593 and CSH95103

Legend

SST Température d'évaporation (°F)

SH Surchauffe du gaz aspiré (°F)

SDT Température de condensation (°F)

■ Puissance de compresseur max. 75%

■ Injection de liquide ou refroidissement d'huile externe nécessaire.

Pour fonctionnement en charge partielle, les limites d'application respectives (CR 75%, CR 50% et CR 25%) peuvent être relevées jusqu'à 10 °F pour la température de condensation, par injection de liquide, mais au maximum jusqu'aux limites à pleine charge.

■ Refroidissement d'huile externe nécessaire

① Température de condensation maximale en cas de CSH8583, CSH8593, CSH9593 et CSH95103

② Température de condensation maximale en cas de CSH8583, CSH8593, CSH9583, CSH9593 et CSH95103

Leyenda

SST Temperatura de evaporación (°F)

SH Sobrecalentamiento del gas aspirado (°F)

SDT Temperatura de condensación (°F)

■ Capacidad de compresor máx. 75%

■ Inyección de refrigerante o refrigeración externa del aceite requeridas.

En el funcionamiento con carga parcial los límites de aplicación respectivos (CR 75%, CR 50%, CR 25%) pueden ser aumentados en 10 °F por la temperatura de condensación mediante la inyección de refrigerante, hasta alcanzar como máximo la carga plena.

■ Refrigeración externa del aceite requerida

① Temperatura de condensación máxima por CSH8583, CSH8593, CSH9593 y CSH95103

② Temperatura de condensación máxima por CSH8583, CSH8593, CSH9583, CSH9593 y CSH95103



Performance data 60 Hz

based on 20°F suction superheat,
15°F liquid subcooling

Données de puissance 60 Hz

se référant à surchauffe du gaz aspiré
de 20°F, 15°F sous-refroidissement de
liquide

Datos de rendimiento 60 Hz

sobre la base de un sobrecalentamiento
del gas aspirado de 20°F, 15°F subenfria-
miento del líquido

Compressor type Compresseur type Tipo de compresor ①	Cond. temp. Temp. de Cond. Temp. de Cond. °F	↓	Cooling capacity Puissance frigorifique Potencia refrigeradora				Power consumption Puissance absorbée Consumo de potencia			
			Q_o [kBTUH]				P_e [kW]			
			Evaporation temperature °F		Température d'évaporation °F		Temperatura de evaporación °F			
55	45	35	25	20	15	10	5			
CSH6553-35Y	90	Q	561	458	369	294	261	231	203	177
		P	22.1	21.0	20.1	19.4	19.2	18.9	18.7	18.5
	110	Q	504	408	326	256	225	197	171	148
		P	26.2	25.3	24.4	23.6	23.3	22.9	22.6	22.3
	130	Q	436	349	275	212	185	159	136	115
		P	31.9	31.0	30.1	29.2	28.8	28.5	28.1	27.8
CSH6563-40Y	90	Q	700	569	459	366	325	287	253	222
		P	28.5	26.7	25.3	24.1	23.6	23.2	22.9	22.7
	110	Q	625	506	405	320	283	249	217	189
		P	33.4	31.8	30.4	29.2	28.6	28.2	27.8	27.4
	130	Q	542	436	346	270	236	206	177	151
		P	39.8	38.5	37.3	36.3	35.8	35.4	35.1	34.8
CSH6583-50Y	90	Q	810	660	533	425	377	334	294	257
		P	29.9	28.6	27.5	26.5	26.0	25.6	25.2	24.8
	110	Q	723	586	469	371	328	288	252	219
		P	36.1	34.7	33.5	32.4	31.9	31.4	30.9	30.5
	130	Q	626	502	398	311	273	238	206	178
		P	44.0	42.6	41.3	40.2	39.7	39.2	38.7	38.3
CSH6593-60Y	90	Q	913	745	601	479	426	376	331	290
		P	33.4	31.9	30.7	29.6	29.1	28.6	28.1	27.7
	110	Q	815	661	529	418	370	325	284	247
		P	40.4	38.8	37.4	36.2	35.6	35.1	34.6	34.1
	130	Q	706	567	449	351	308	269	233	201
		P	49.2	47.6	46.2	44.9	44.3	43.8	43.3	42.8
CSH7553-50Y	90	Q	816	658	526	414	366	322	281	245
		P	32.4	30.2	28.5	27.3	26.8	26.3	25.8	25.4
	110	Q	725	581	460	359	315	275	239	207
		P	38.7	36.6	35.0	33.8	33.2	32.7	32.2	31.7
	130	Q	620	492	385	297	259	224	193	165
		P	47.2	45.3	43.8	42.5	41.9	41.3	40.7	40.1
CSH7563-60Y	90	Q	960	775	619	488	431	379	332	289
		P	37.4	34.8	32.9	31.4	30.8	30.3	29.8	29.3
	110	Q	854	684	542	423	371	325	282	244
		P	44.5	42.2	40.4	38.9	38.2	37.6	37.1	36.5
	130	Q	731	580	455	351	306	265	229	196
		P	54.4	52.2	50.4	48.9	48.2	47.6	46.9	46.2
CSH7573-70Y	90	Q	1102	890	711	561	495	436	382	332
		P	42.5	39.6	37.4	35.7	35.0	34.4	33.8	33.3
	110	Q	981	786	623	486	427	373	325	281
		P	50.6	48.0	45.9	44.2	43.5	42.8	42.1	41.5
	130	Q	840	667	523	403	352	305	264	226
		P	61.8	59.3	57.3	55.6	54.8	54.1	53.3	52.5
CSH7583-80Y	90	Q	1232	1003	808	644	573	507	447	393
		P	48.7	45.1	42.2	40.0	39.2	38.7	38.3	38.1
	110	Q	1118	903	722	569	503	442	387	337
		P	57.6	54.7	52.1	49.9	49.0	48.2	47.5	47.0
	130	Q	975	780	616	479	420	366	317	272
		P	69.3	67.1	64.9	62.8	61.7	60.7	59.8	58.9
CSH7593-90Y	90	Q	1403	1142	921	734	652	578	510	448
		P	55.4	51.4	48.1	45.6	44.7	44.0	43.6	43.4
	110	Q	1273	1029	822	648	573	504	441	384
		P	65.6	62.3	59.3	56.8	55.8	54.9	54.1	53.5
	130	Q	1111	889	702	546	478	417	361	310
		P	79.0	76.4	73.9	71.5	70.3	69.2	68.1	67.1
CSH8553-80Y	90	Q	1299	1058	852	679	603	534	471	413
		P	51.1	48.1	45.6	43.6	42.8	42.1	41.6	41.1
	110	Q	1173	948	757	596	526	462	404	350
		P	60.8	58.1	55.8	53.9	53.1	52.3	51.7	51.2
	130	Q	1033	826	652	505	442	383	331	283
		P	74.8	72.3	70.1	68.1	67.2	66.4	65.6	64.9
CSH8563-90Y	90	Q	1496	1218	982	783	695	615	542	476
		P	58.3	54.9	52.0	49.7	48.8	48.0	47.4	46.9
	110	Q	1351	1092	872	687	607	533	465	404
		P	69.3	66.3	63.6	61.4	60.5	59.7	58.9	58.3
	130	Q	1190	952	752	583	509	442	382	326
		P	85.2	82.4	79.9	77.6	76.6	75.6	74.8	74.0
CSH8573-110Y	90	Q	1767	1436	1157	921	818	724	639	561
		P	66.2	62.3	59.1	56.5	55.4	54.6	53.8	53.3
	110	Q	1596	1289	1029	812	717	631	552	481
		P	78.7	75.3	72.3	69.8	68.7	67.8	67.0	66.3
	130	Q	1379	1106	876	684	600	524	455	393
		P	96.8	93.6	90.8	88.2	87.0	86.0	84.9	84.0
CSH8583-125Y	90	Q	1957	1593	1284	1024	910	805	710	624
		P	74.4	70.1	66.4	63.5	62.3	61.3	60.5	59.9
	110	Q	1753	1418	1135	897	793	698	612	533
		P	88.5	84.6	81.3	78.5	77.3	76.2	75.3	74.5
	130	Q	1528	1227	973	760	667	583	506	436
		P	108.8	105.3	102.1	99.2	97.8	96.6	95.5	94.5

Performance data 60 Hz

based on 20°F suction superheat,
15°F liquid subcooling

Données de puissance 60 Hz

se référant à surchauffe du gaz aspiré
de 20°F, 15°F sous-refroidissement de
liquide

Datos de rendimiento 60 Hz

sobre la base de un sobrecalentamiento
del gas aspirado de 20°F, 15°F subenfria-
miento del líquido

Compressor type Compresseur type Tipo de compresor ①	Cond. temp. Temp. de Cond. Temp. de Cond. °F	↓	Cooling capacity Puissance frigorifique Potencia refrigeradora				Power consumption Puissance absorbée Consumo de potencia									
			Q_o			[kBTUH]	P_e			[kW]						
			Evaporation temperature °F		Température d'évaporation °F		Temperatura de evaporación °F									
55		45		35		25		20		15		10		5		
CSH8593-140Y	90	Q	2228	1813	1462	1165	1035	917	809	710						
		P	84.7	79.8	75.6	72.3	71.0	69.8	68.9	68.2						
	110	Q	1995	1614	1292	1021	903	795	696	607						
		P	100.7	96.3	92.5	89.3	88.0	86.7	85.7	84.8						
	130	Q	1739	1397	1108	865	760	663	576	497						
		P	123.9	119.8	116.2	112.9	111.4	110.0	108.7	107.5						
CSH9553-180Y	90	Q	2241	1830	1479	1181	1050	929	817	715						
		P	86.3	81.4	77.7	74.9	73.7	72.7	71.7	70.7						
	110	Q	2012	1632	1307	1032	910	798	695	600						
		P	99.4	97.2	94.6	91.8	90.3	88.9	87.5	86.2						
	130	Q	1746	1403	1111	864	755	655	563	478						
		P	123.4	121.0	118.1	114.8	113.2	111.5	109.9	108.4						
CSH9563-160Y	90	Q	2630	2147	1736	1387	1232	1091	960	840						
		P	99.2	93.5	89.3	86.1	84.8	83.5	82.4	81.3						
	110	Q	2362	1916	1535	1212	1070	938	818	706						
		P	114.2	111.8	108.8	105.5	103.8	102.2	100.6	99.0						
	130	Q	2051	1649	1307	1017	889	771	664	565						
		P	141.9	139.1	135.7	132.0	130.1	128.2	126.3	124.6						
CSH9573-180Y	90	Q	3048	2476	1991	1584	1407	1245	1098	964						
		P	110.8	105.0	100.5	96.8	95.2	93.6	92.0	90.3						
	110	Q	2775	2238	1786	1407	1243	1093	958	836						
		P	133.6	127.6	122.8	118.8	116.9	115.1	113.3	111.4						
	130	Q	2407	1929	1528	1194	1049	918	799	692						
		P	160.9	155.0	150.2	146.1	144.2	142.3	140.4	138.4						
CSH9583-210Y	90	Q	3430	2802	2269	1818	1621	1440	1275	1125						
		P	123.8	119.2	114.9	110.8	108.8	106.9	105.1	103.3						
	110	Q	3100	2519	2026	1610	1428	1261	1110	971						
		P	150.5	146.0	141.5	136.9	134.7	132.5	130.4	128.2						
	130	Q	2737	2206	1757	1380	1215	1064	927	803						
		P	186.0	181.0	175.8	170.5	167.8	165.1	162.4	159.7						
CSH9593-240Y	90	Q	3897	3184	2578	2066	1842	1637	1449	1278						
		P	139.9	134.8	129.9	125.2	123.0	120.8	118.8	116.8						
	110	Q	3523	2862	2302	1830	1623	1434	1261	1104						
		P	170.2	165.1	159.9	154.8	152.3	149.8	147.4	145.0						
	130	Q	3110	2507	1997	1568	1381	1210	1054	913						
		P	210.2	204.6	198.7	192.7	189.7	186.6	183.6	180.5						
CSH95103-280Y	90	Q	4224	3445	2784	2226	1982	1758	1555	1369						
		P	159.6	154.7	149.7	144.9	142.6	140.3	138.2	136.2						
	110	Q	3816	3093	2480	1965	1739	1534	1346	1176						
		P	199.5	190.9	183.5	177.2	174.4	171.7	169.2	166.9						
	130	Q	3361	2698	2139	1669	1464	1278	1108	955						
		P	240.7	232.0	224.2	217.1	213.9	210.8	207.9	205.1						

Performance data for individual input data see BITZER Software.

① Data are valid for compressors of motor version 2. For higher condensing temperatures motor version 1 may be required. Application limits see page 8, performance data see BITZER Software.

! For operation with R134a polyol-ester oil BSE170 is required

Additional cooling:
Liquid injection or external oil cooling

Données de puissance pour des données d'entrée individuelles voir BITZER Software.

① Les données sont valables pour le moteur version 2. Pour des températures de condensation plus élevées, le moteur version 1 peut devenir nécessaire. Limites d'application voir page 8, données de puissance voir BITZER Software.

! Pour le fonctionnement avec R134a il est nécessaire d'utiliser de l'huile polyoléster BSE170

Refrigeration additionnel:
Injection de liquide ou refroidissement d'huile externe

Datos de rendimiento para datos de entrada individuales ver BITZER Software.

① Los datos son válidos para compresores con la versión 2 del motor. Para temperaturas de condensación más elevadas puede hacerse necesaria la versión 1 del motor. Los límites de aplicación ver página 8, los datos de rendimiento ver BITZER Software.

! Para el funcionamiento con R134a es necesario aceite poliéster BSE170

Refrigeración adicional:
Inyección de refrigerante o refrigeración externa del aceite



Performance data 60 Hz
based on 20°F suction superheat ①

Données de puissance 60 Hz
se référant à surchauffe du gaz aspiré
de 20°F ①

Datos de rendimiento 60 Hz
sobre la base de un sobrecalentamiento
del gas aspirado de 20°F ①

Compressor type Compresseur type Tipo de compresor ②	Cond. temp. Temp. de Cond. Temp. de Cond. °F	↓	Cooling capacity Puissance frigorifique Potencia refrigeradora			Power consumption Puissance absorbée Consumo de potencia				
			Q_o [kBTUH]			P_e [kW]				
			Evaporation temperature °F			Température d'évaporation °F			Temperatura de evaporación °F	
			55	45	40	35	30	20	10	0
CSH6553-35Y	90	Q	455	416	379	345	282	226	177	
		P	22.6	22.4	22.2	22.0	21.6	21.1	20.6	
	110	Q	514	430	392	355	321	259	204	155
		P	29.2	28.7	28.4	28.0	27.7	26.8	26.0	25.3
	130	Q	473	392	355	320	287	227	175	129
		P	37.2	36.4	35.9	35.4	34.8	33.7	32.7	31.9
CSH6563-40Y	90	Q	556	509	463	421	344	277	219	
		P	28.1	27.7	27.3	26.9	26.1	25.5	25.0	
	110	Q	625	523	477	433	392	318	252	196
		P	36.3	35.2	34.7	34.1	33.5	32.4	31.4	30.6
	130	Q	575	478	434	392	353	282	220	165
		P	45.2	44.0	43.4	42.8	42.2	40.9	39.9	39.0
CSH6583-50Y	90	Q	647	591	538	488	398	320	251	
		P	30.3	30.1	29.8	29.5	28.8	28.0	27.1	
	110	Q	724	604	550	499	451	364	288	224
		P	39.4	38.6	38.1	37.6	37.1	36.0	34.8	33.6
	130	Q	660	546	494	446	401	320	251	192
		P	49.9	48.6	47.9	47.2	46.5	45.1	43.8	42.6
CSH6593-60Y	90	Q	717	655	597	542	442	355	279	
		P	33.1	32.9	32.7	32.4	31.7	30.8	29.9	
	110	Q	802	670	610	554	501	405	321	249
		P	43.0	42.2	41.8	41.3	40.8	39.6	38.4	37.2
	130	Q	731	606	549	495	445	355	279	214
		P	54.6	53.4	52.7	52.0	51.2	49.8	48.4	47.1
CSH7553-50Y	90	Q	653	594	538	486	393	312	243	
		P	32.5	31.9	31.4	31.0	30.1	29.2	28.2	
	110	Q	737	610	552	499	449	359	282	217
		P	42.7	41.3	40.6	40.0	39.4	38.1	36.8	35.5
	130	Q	667	548	494	443	397	314	244	185
		P	54.3	52.6	51.8	50.9	50.1	48.5	46.9	45.3
CSH7563-60Y	90	Q	757	688	624	564	456	362	282	
		P	36.6	36.1	35.5	35.0	34.1	33.1	32.1	
	110	Q	853	706	639	577	519	416	327	251
		P	48.2	46.6	45.9	45.2	44.5	43.2	41.8	40.3
	130	Q	771	633	571	513	459	363	282	215
		P	61.3	59.4	58.5	57.6	56.7	55.0	53.2	51.4
CSH7573-70Y	90	Q	853	777	705	637	515	410	320	
		P	40.8	40.2	39.6	39.1	38.1	37.1	36.0	
	110	Q	962	797	722	652	587	470	370	285
		P	53.6	52.0	51.2	50.4	49.7	48.3	46.8	45.2
	130	Q	870	715	645	580	519	411	319	243
		P	68.2	66.2	65.3	64.4	63.4	61.5	59.7	57.7
CSH7583-80Y	90	Q	978	893	813	738	603	485	384	
		P	47.4	46.5	45.5	44.7	43.3	42.4	42.2	
	110	Q	1114	928	843	765	691	557	442	343
		P	62.1	60.2	59.2	58.1	57.0	55.0	53.2	51.9
	130	Q	1023	844	763	687	616	490	384	294
		P	77.8	75.9	74.8	73.6	72.3	69.8	67.3	65.1
CSH7593-90Y	90	Q	1094	1001	911	828	676	545	431	
		P	52.9	51.9	50.9	50.0	48.5	47.6	47.5	
	110	Q	1247	1039	945	857	774	625	496	386
		P	69.3	67.3	66.2	65.0	63.9	61.8	59.9	58.4
	130	Q	1145	946	855	770	691	550	430	329
		P	86.9	85.0	83.8	82.5	81.2	78.4	75.7	73.3
CSH8553-80Y	90	Q	1052	961	876	796	651	525	416	
		P	51.9	51.2	50.5	49.7	48.3	47.1	46.2	
	110	Q	1197	1000	911	827	748	605	480	373
		P	67.6	66.0	65.1	64.2	63.2	61.4	59.6	58.0
	130	Q	1120	928	840	758	681	542	422	319
		P	86.8	84.6	83.4	82.2	80.9	78.4	76.0	73.9
CSH8563-90Y	90	Q	1192	1090	993	903	739	596	473	
		P	57.9	57.2	56.4	55.7	54.2	52.9	52.0	
	110	Q	1355	1133	1032	936	847	686	545	423
		P	75.4	73.7	72.8	71.8	70.8	68.8	66.9	65.3
	130	Q	1266	1050	951	858	771	614	478	362
		P	96.8	94.6	93.3	92.0	90.7	88.0	85.4	83.2
CSH8573-110Y	90	Q	1378	1261	1150	1045	855	691	549	
		P	64.3	63.6	62.8	62.0	60.5	59.2	58.2	
	110	Q	1570	1312	1194	1084	981	795	634	496
		P	83.7	81.9	81.0	79.9	78.9	76.8	74.8	73.1
	130	Q	1438	1195	1084	980	883	708	558	430
		P	107.6	105.3	104.0	102.7	101.2	98.3	95.5	93.0
CSH8583-125Y	90	Q	1553	1418	1291	1171	956	770	609	
		P	73.8	72.8	71.7	70.7	68.7	67.0	65.7	
	110	Q	1746	1456	1325	1202	1087	878	697	543
		P	95.8	93.4	92.1	90.8	89.5	86.8	84.3	82.2
	130	Q	1602	1327	1201	1084	974	778	611	470
		P	122.3	119.3	117.6	115.8	114.0	110.5	107.3	104.6

Performance data 60 Hz

based on 20°F suction superheat ①

Données de puissance 60 Hz

se référant à surchauffe du gaz aspiré de 20°F ①

Datos de rendimiento 60 Hz

sobre la base de un sobrecalentamiento del gas aspirado de 20°F ①

Compressor type Temp. de Cond. Temp. de Cond. °F ②	Cond. temp. Temp. de Cond. Temp. de Cond. °F ②	Cooling capacity Puissance frigorifique Potencia refrigeradora			Q _o	Power consumption Puissance absorbée Consumo de potencia			P _e	[kW]			
		Evaporation temperature °F				Température d'évaporation °F					Temperatura de evaporación °F		
		55	45	40		35	30	20			10	0	
CSH8593-140Y	90	Q	1742	1592	1450	1316	1074	865	684				
		P	82.4	81.4	80.3	79.2	77.1	75.4	74.0				
	110	Q	1958	1634	1487	1349	1219	986	783	610			
		P	107.0	104.5	103.2	101.8	100.4	97.5	94.8	92.6			
	130	Q	1795	1487	1347	1215	1092	871	684	526			
		P	136.8	133.6	131.8	129.9	128.0	124.2	120.8	117.7			
CSH9553-180Y	90	Q	1806	1649	1501	1363	1111	889	693				
		P	87.0	85.8	84.8	83.7	81.7	79.5	77.1				
	110	Q	2026	1690	1537	1392	1257	1009	793	604			
		P	109.3	108.5	107.6	106.4	105.0	101.6	98.1	94.8			
	130	Q	1844	1523	1376	1238	1110	880	681	508			
		P	140.2	137.9	136.2	134.3	132.2	128.1	124.0	120.2			
CSH9563-160Y	90	Q	2089	1908	1737	1576	1285	1029	803				
		P	98.1	96.9	95.8	94.7	92.5	90.2	87.6				
	110	Q	2341	1953	1776	1609	1453	1167	916	699			
		P	123.1	122.4	121.5	120.2	118.7	115.1	111.3	107.7			
	130	Q	2129	1758	1589	1430	1282	1016	786	587			
		P	158.1	155.7	153.9	151.9	149.7	145.0	140.5	136.4			
CSH9573-180Y	90	Q	2375	2165	1967	1781	1449	1162	917				
		P	108.3	107.3	106.2	105.1	102.6	102.6	99.7	96.1			
	110	Q	2711	2248	2039	1844	1663	1336	1057	823			
		P	141.1	137.4	135.6	133.8	132.0	128.1	123.9	119.3			
	130	Q	2458	2024	1828	1645	1475	1175	924	715			
		P	176.2	171.1	168.6	166.1	163.6	158.9	154.3	149.3			
CSH9583-210Y	90	Q	3229	2715	2476	2252	2043	1667	1340	1060			
		P	125.1	124.6	123.6	122.3	120.9	117.5	113.7	109.8			
	110	Q	3048	2536	2304	2087	1883	1517	1205	942			
		P	160.7	158.0	156.2	154.2	151.9	146.9	141.7	136.7			
	130	Q	2788	2294	2071	1864	1673	1336	1050	806			
		P	203.6	198.7	195.8	192.8	189.7	183.5	177.1	170.4			
CSH9593-240Y	90	Q	3041	2776	2526	2293	2093	1872	1507	1192			
		P	138.4	137.5	136.2	134.7	131.2	131.2	127.2	123.0			
	110	Q	3416	2844	2585	2342	2115	1705	1353	1057			
		P	178.5	175.9	174.1	172.0	169.6	164.3	158.7	153.2			
	130	Q	3126	2576	2327	2094	1879	1498	1177	904			
		P	226.8	221.8	218.8	215.5	212.1	205.2	198.3	191.1			
CSH95103-280Y	90	Q	3326	3026	2746	2485	2216	1610	1267				
		P	160.7	159.6	158.1	156.4	152.3	147.7	143.1				
	110	Q	3727	3085	2794	2522	2268	1816	1434	1115			
		P	210.8	204.2	200.9	197.5	194.1	187.6	181.7	176.2			
	130	Q	3378	2759	2482	2226	1990	1600	1225	924			
		P	260.0	251.1	246.7	242.5	238.5	231.0	224.0	216.9			

Performance data for individual input data see BITZER Software.

- ① Economiser operation: Performance data with liquid subcooling ($t_{cu} = t_{ms} + 10^{\circ}F$)
- ② Data are valid for compressors of motor version 2. For higher condensing temperatures motor version 1 may be required. Application limits see page 8, performance data see BITZER Software.

For operation with R134a polyol-ester oil BSE170 is required

Additional cooling:
Liquid injection or external oil cooling

Données de puissance pour des données d'entrée individuelles voir BITZER Software.

- ① Fonctionnement avec économiseur: données de puissance avec sous-refroidissement de liquide ($t_{cu} = t_{ms} + 10^{\circ}F$)
- ② Les données sont valables pour le moteur version 2. Pour des températures de condensation plus élevées, le moteur version 1 peut devenir nécessaire. Limites d'application voir page 8, données de puissance voir BITZER Software.

Pour le fonctionnement avec R134a il est nécessaire d'utiliser de l'huile polyolester BSE170

Refrigeration additionnel:
Injection de liquide ou refroidissement d'huile externe

Datos de rendimiento para datos de entrada individuales ver BITZER Software.

- ① Funcionamiento con economizador: datos de rendimiento con subenfriamiento del líquido ($t_{cu} = t_{ms} + 10^{\circ}F$)
- ② Los datos son válidos para compresores con la versión 2 del motor. Para temperaturas de condensación más elevadas puede hacerse necesaria la versión 1 del motor. Los límites de aplicación ver página 8, los datos de rendimiento ver BITZER Software.

Para el funcionamiento con R134a es necesario aceite polioléster BSE170

Refrigeración adicional:
Inyección de refrigerante o refrigeración externa del aceite



Performance data 60 Hz

based on 20°F suction superheat,
15°F liquid subcooling

Données de puissance 60 Hz

se référant à surchauffe du gaz aspiré
de 20°F, 15°F sous-refroidissement de
liquide

Datos de rendimiento 60 Hz

sobre la base de un sobrecalentamiento
del gas aspirado de 20°F, 15°F subenfria-
miento del líquido

Compressor type Compresseur type Tipo de compresor	Cond. temp. Temp. de Cond. Temp. de Cond. °F	↓	Cooling capacity Puissance frigorifique Potencia refrigeradora			Q _o	[kBTUH]	Power consumption Puissance absorbée Consumo de potencia			P _e	[kW]			
			Evaporation temperature °F					Température d'évaporation °F					Temperatura de evaporación °F		
			50	40	35			30	25	20			10	0	
CSH6553-50	90	Q	583	530	480	434	390	313	247						
		P		31.8	31.7	31.3	30.7	29.9	28.1	26.4					
	110	Q	627	518	468	422	380	340	269	208					
		P	40.5	39.3	38.4	37.5	36.5	35.6	33.7	32.3					
	130	Q	555	453	408	365	326	290	225	170					
		P	51.7	48.9	47.6	46.3	45.0	43.9	42.0	40.7					
CSH6563-60	90	Q	731	664	602	544	490	393	310						
		P		39.5	39.4	38.9	38.1	37.1	34.8	32.7					
	110	Q	787	650	588	530	477	427	338	262					
		P	50.3	48.7	47.7	46.6	45.4	44.1	41.8	40.0					
	130	Q	697	569	512	459	409	364	282	213					
		P	64.1	60.7	59.0	57.4	55.9	54.5	52.1	50.5					
CSH7553-70	90	Q	854	777	705	638	575	462	363						
		P		48.8	47.6	46.6	45.5	44.4	42.5	40.7					
	110	Q	916	758	687	620	558	500	396	306					
		P	61.4	58.8	57.5	56.4	55.3	54.3	52.5	51.0					
	130	Q	787	641	576	516	460	409	319	243					
		P	75.3	72.3	71.0	69.8	68.7	67.6	65.4	63.0					
CSH7563-80	90	Q	998	908	824	746	673	541	426						
		P		55.5	54.1	52.9	51.8	50.7	48.7	46.7					
	110	Q	1061	878	796	719	648	581	461	357					
		P	69.7	66.3	64.9	63.6	62.5	61.5	59.7	58.0					
	130	Q	903	737	663	594	531	472	368	282					
		P	84.4	80.8	79.4	78.2	77.0	76.0	73.9	71.3					
CSH7573-90	90	Q	1184	1080	983	892	806	652	516						
		P		63.3	62.0	60.8	59.6	58.3	56.0	53.8					
	110	Q	1268	1056	960	870	786	708	566	440					
		P	79.3	76.2	74.7	73.4	72.1	71.0	68.9	67.1					
	130	Q	1099	903	816	734	658	588	462	355					
		P	97.2	93.5	92.0	90.5	89.1	87.8	85.1	82.1					
CSH7583-100	90	Q	1317	1196	1083	978	881	707	559						
		P		74.5	71.9	69.7	67.7	66.1	63.3	60.8					
	110	Q	1410	1166	1056	954	859	771	615	481					
		P	90.8	87.1	85.5	84.1	82.8	81.5	79.0	76.1					
	130	Q	1224	1004	906	815	730	653	515	400					
		P	107.2	106.7	105.9	104.8	103.4	101.8	98.2	94.4					
CSH7593-110	90	Q	1502	1364	1235	1116	1004	806	636						
		P		85.0	82.0	79.5	77.3	75.4	72.2	69.3					
	110	Q	1609	1329	1204	1087	978	878	699	546					
		P	103.5	99.3	97.6	96.0	94.4	93.0	90.1	86.8					
	130	Q	1393	1142	1030	926	830	741	585	454					
		P	122.3	121.7	120.7	119.4	117.9	116.0	111.9	107.7					
CSH8553-110	90	Q	1433	1300	1176	1061	954	762	599						
		P		78.9	75.4	72.7	70.8	69.3	67.4	65.7					
	110	Q	1530	1261	1141	1028	924	827	655	507					
		P	98.0	91.4	89.3	87.7	86.6	85.7	84.6	83.3					
	130	Q	1305	1068	962	864	772	687	536	408					
		P	118.1	113.6	112.1	110.8	109.7	108.7	106.2	102.4					
CSH8563-125	90	Q	1634	1482	1340	1209	1087	869	682						
		P		89.9	85.9	82.9	80.6	79.0	76.8	74.9					
	110	Q	1744	1438	1300	1172	1053	943	746	578					
		P	111.7	104.2	101.7	99.9	98.6	97.7	96.4	94.9					
	130	Q	1487	1218	1097	984	880	783	611	465					
		P	134.5	129.5	127.7	126.3	125.0	123.8	121.0	116.7					
CSH8573-140	90	Q	1873	1716	1568	1430	1300	1062	849						
		P		108.9	105.3	102.2	99.6	97.3	93.3	89.1					
	110	Q	2027	1696	1545	1404	1272	1147	920	718					
		P	135.0	127.8	124.9	122.3	120.0	117.8	113.7	109.4					
	130	Q	1780	1456	1311	1176	1051	935	729	553					
		P	160.5	153.9	151.1	148.4	145.9	143.4	138.3	132.3					
CSH8583-160	90	Q	2104	1923	1754	1596	1447	1175	933						
		P		115.2	110.9	107.3	104.2	101.5	97.1	93.4					
	110	Q	2284	1900	1726	1564	1412	1269	1010	781					
		P	145.0	136.5	132.9	129.6	126.7	124.1	119.5	115.5					
	130	Q	2011	1637	1470	1315	1171	1038	802	603					
		P	173.8	165.8	162.3	159.0	155.9	153.0	147.4	141.9					

Performance data 60 Hz

based on 20°F suction superheat,
15°F liquid subcooling

Données de puissance 60 Hz

se référant à surchauffe du gaz aspiré
de 20°F, 15°F sous-refroidissement de
liquide

Datos de rendimiento 60 Hz

sobre la base de un sobrecalentamiento
del gas aspirado de 20°F, 15°F subenfria-
miento del líquido

Compressor type Compresseur type Tipo de compresor	Cond. temp. Temp. de Cond. Temp. de Cond. °F	↓	Cooling capacity Puissance frigorifique Potencia refrigeradora			Q _o	Power consumption Puissance absorbée Consumo de potencia			P _e	[kW]			
			Evaporation temperature °F				Température d'évaporation °F					Temperatura de evaporación °F		
			50	40	35		30	25	20			10	0	
CSH8593-180	90	Q	2446	2236	2039	1855	1682	1367	1086					
		P	131.1	126.3	122.1	118.6	115.6	110.6	106.3					
	110	Q	2658	2211	2009	1820	1643	1478	1177	912				
		P	165.0	155.4	151.3	147.6	144.2	141.2	136.0	131.5				
	130	Q	2348	1912	1716	1535	1367	1212	937	706				
		P	197.9	188.8	184.8	181.0	177.5	174.2	167.8	161.5				
CSH9553-180	90	Q	2483	2253	2039	1839	1653	1318	1029					
		P	135.6	130.9	127.0	123.7	120.9	116.8	113.9					
	110	Q	2710	2232	2017	1816	1630	1456	1144	875				
		P	163.8	157.0	153.6	150.1	146.8	143.8	138.5	135.1				
	130	Q	2379	1944	1748	1565	1396	1238	955	710				
		P	198.5	189.7	185.8	182.3	179.0	175.9	169.8	163.4				
CSH9563-210	90	Q	2874	2608	2359	2129	1915	1534	1210					
		P	154.6	149.2	144.5	140.4	137.0	131.7	128.2					
	110	Q	3150	2596	2348	2117	1902	1704	1350	1049				
		P	189.1	179.8	175.7	171.8	168.3	165.1	159.7	155.8				
	130	Q	2779	2273	2046	1836	1640	1459	1138	864				
		P	226.3	216.2	212.2	208.5	205.2	202.0	195.2	187.0				
CSH9573-240	90	Q	3336	3025	2736	2468	2220	1778	1402					
		P	172.2	166.9	162.0	157.5	153.4	146.1	139.8					
	110	Q	3610	2981	2699	2437	2194	1969	1568	1229				
		P	212.8	202.0	197.2	192.7	188.6	184.8	177.9	171.7				
	130	Q	3168	2608	2356	2123	1907	1707	1351	1049				
		P	251.1	241.3	236.9	232.7	228.9	225.2	218.5	212.3				
CSH9583-280	90	Q	3677	3345	3038	2754	2491	2027	1639					
		P	195.2	189.6	184.2	179.2	174.7	168.0	165.5					
	110	Q	4047	3360	3053	2769	2505	2263	1835	1477				
		P	242.5	230.5	224.7	219.1	214.0	209.5	202.6	199.6				
	130	Q	3619	2992	2710	2448	2205	1979	1577	1234				
		P	289.9	276.5	270.2	264.3	258.8	254.0	246.5	242.7				
CSH9593-300	90	Q	4190	3821	3478	3160	2866	2345	1905					
		P	220.6	214.3	208.2	202.6	197.5	190.0	187.3					
	110	Q	4575	3806	3462	3143	2847	2573	2088	1680				
		P	274.1	260.5	253.9	247.7	241.9	236.8	229.1	225.8				
	130	Q	4087	3379	3061	2765	2490	2235	1781	1393				
		P	327.8	312.7	305.6	298.9	292.7	287.3	278.8	274.5				

Performance data for individual input data see BITZER Software.

Données de puissance pour des données d'entrée individuelles voir BITZER Software.

Datos de rendimiento para datos de entrada individuales ver BITZER Software.

! For operation with R22 the oil B320H is required

Additional cooling:
Liquid injection or external oil cooling

! Pour le fonctionnement avec R22 il est nécessaire d'utiliser de l'huile B320H

Refrigidissement additionnel:
Injection de liquide ou refroidissement d'huile externe

! Para el funcionamiento con R22 es necesario aceite B320H

Refrigeración adicional:
Inyección de refrigerante o refrigeración externa del aceite



Performance data 60 Hz
based on 20°F suction superheat ①

Données de puissance 60 Hz
se référant à surchauffe du gaz aspiré
de 20°F ①

Datos de rendimiento 60 Hz
sobre la base de un sobrecalentamiento
del gas aspirado de 20°F ①

Compressor type Compresseur type Tipo de compresor	Cond. temp. Temp. de Cond. Temp. de Cond. °F	↓	Cooling capacity Puissance frigorifique Potencia refrigeradora			Q _o	[kBTUH]	Power consumption Puissance absorbée Consumo de potencia			P _e	[kW]			
			Evaporation temperature °F					Température d'évaporation °F					Temperatura de evaporación °F		
			50	40	35			30	25	20			10	0	
CSH6553-50	85	Q	596	550	506	465	425	352	287						
		P	32.4	32.8	32.9	32.6	32.0	30.5	28.8						
	105	Q	657	560	515	472	431	393	322						
		P	41.8	41.9	41.5	40.9	40.1	39.2	37.3						
	125	Q	618	522	478	436	397	359	290						
		P	56.2	54.0	52.7	51.5	50.3	49.1	46.9						
CSH6563-60	85	Q	734	678	624	573	524	434	354						
		P	39.2	39.8	39.9	39.6	38.9	37.1	35.1						
	105	Q	809	689	634	581	531	483	396						
		P	50.5	50.8	50.3	49.6	48.7	47.6	45.4						
	125	Q	758	641	587	536	487	441	356						
		P	68.0	65.4	63.9	62.5	61.0	59.6	57.0						
CSH7553-70	85	Q	870	804	740	679	621	514	417						
		P	49.7	49.2	48.5	47.8	47.0	45.4	43.6						
	105	Q	959	818	753	691	632	576	472						
		P	63.8	62.4	61.6	60.6	59.7	58.7	56.8						
	125	Q	880	743	680	620	563	509	411						
		P	81.7	79.2	77.9	76.7	75.5	74.3	71.8						
CSH7563-80	85	Q	1001	926	853	783	717	594	483						
		P	55.4	54.8	54.2	53.6	52.9	51.3	49.4						
	105	Q	1093	935	861	790	723	659	541						
		P	71.1	69.2	68.3	67.4	66.5	65.6	63.8						
	125	Q	994	841	770	703	639	578	468						
		P	90.2	87.2	86.0	84.8	83.7	82.6	80.3						
CSH7573-90	85	Q	1162	1078	996	918	843	702	573						
		P	61.6	61.4	60.9	60.3	59.6	57.8	55.8						
	105	Q	1277	1098	1014	934	857	784	648						
		P	78.7	77.6	76.9	76.0	75.1	74.1	72.2						
	125	Q	1178	1003	921	844	770	700	570						
		P	101.0	98.3	97.1	95.8	94.6	93.3	90.7						
CSH7583-100	85	Q	1321	1217	1119	1025	936	773	629						
		P	74.8	72.9	71.2	69.7	68.4	65.9	63.6						
	105	Q	1449	1234	1135	1040	951	867	712						
		P	93.8	91.0	89.7	88.6	87.4	86.3	83.8						
	125	Q	1332	1128	1034	945	861	781	637						
		P	114.2	113.9	113.2	112.2	110.8	109.3	105.5						
CSH7593-110	85	Q	1477	1364	1254	1150	1051	868	707						
		P	83.3	81.4	79.6	78.1	76.6	74.0	71.5						
	105	Q	1623	1383	1272	1166	1066	971	798						
		P	104.5	101.7	100.4	99.1	98.0	96.8	94.1						
	125	Q	1489	1261	1156	1056	962	873	712						
		P	127.4	127.3	126.7	125.7	124.3	122.7	118.7						
CSH8553-110	85	Q	1463	1347	1237	1133	1034	852	691						
		P	82.0	79.0	76.6	74.9	73.5	71.6	69.8						
	105	Q	1610	1369	1258	1152	1052	957	783						
		P	103.7	98.1	96.2	94.8	93.8	93.1	91.8						
	125	Q	1468	1242	1138	1039	945	856	693						
		P	128.8	124.8	123.2	121.9	120.7	119.6	116.9						
CSH8563-125	85	Q	1638	1510	1388	1271	1161	958	777						
		P	91.4	88.2	85.6	83.7	82.3	80.3	78.4						
	105	Q	1803	1535	1410	1292	1180	1074	879						
		P	115.5	109.5	107.5	106.0	105.0	104.3	103.0						
	125	Q	1642	1391	1274	1164	1059	960	778						
		P	143.7	139.3	137.8	136.5	135.3	134.1	131.3						
CSH8573-140	85	Q	1830	1707	1587	1471	1358	1145	946						
		P	106.7	104.6	102.6	100.9	99.2	96.0	92.2						
	105	Q	2034	1763	1634	1511	1392	1278	1063						
		P	135.5	130.9	128.8	126.9	125.1	123.4	119.7						
	125	Q	1914	1629	1496	1369	1249	1134	921						
		P	167.5	162.8	160.5	158.3	156.0	153.7	148.5						
CSH8583-160	85	Q	2098	1948	1803	1664	1531	1281	1050						
		P	115.4	112.4	109.8	107.4	105.3	101.6	98.1						
	105	Q	2331	2001	1847	1700	1559	1425	1173						
		P	148.7	142.3	139.5	136.8	134.3	131.9	127.5						
	125	Q	2181	1841	1683	1533	1391	1257	1009						
		P	184.4	178.0	174.8	171.7	168.6	165.6	159.5						

Performance data 60 Hz
based on 20°F suction superheat ①

Données de puissance 60 Hz
se référant à surchauffe du gaz aspiré
de 20°F ①

Datos de rendimiento 60 Hz
sobre la base de un sobrecalentamiento
del gas aspirado de 20°F ①

Compressor type Compresseur type Tipo de compresor	Cond. temp. Temp. de Cond. Temp. de Cond. °F	↓	Cooling capacity Puissance frigorifique Potencia refrigeradora			Q _o	Power consumption Puissance absorbée Consumo de potencia			P _e	[kW]			
			Evaporation temperature °F				Température d'évaporation °F					Temperatura de evaporación °F		
			50	40	35		30	25	20			10	0	
CSH8593-180	85	Q	2400	2231	2066	1908	1755	1470	1206					
		P	128.7	125.6	122.8	120.3	118.0	114.0	110.2					
	105	Q	2668	2292	2116	1948	1787	1634	1346	1081				
		P	166.0	159.1	156.0	153.1	150.4	147.8	143.0	138.4				
	125	Q	2501	2111	1930	1759	1596	1442	1159	907				
		P	205.9	198.9	195.5	192.2	188.9	185.5	179.0	172.4				
CSH9553-180	85	Q	2509	2309	2118	1937	1766	1450	1167					
		P	139.7	135.7	132.5	129.9	127.8	124.6	121.8					
	105	Q	2808	2377	2179	1990	1812	1643	1331	1052				
		P	171.2	166.3	163.5	160.5	157.6	154.7	149.4	145.5				
	125	Q	2599	2185	1994	1812	1640	1477	1179	914				
		P	212.3	205.5	201.9	198.3	194.6	190.9	183.9	177.5				
CSH9563-210	85	Q	2859	2631	2414	2208	2014	1659	1346					
		P	155.5	151.4	147.7	144.5	141.7	137.2	133.8					
	105	Q	3209	2719	2493	2280	2078	1888	1540	1234				
		P	193.8	187.1	183.8	180.6	177.5	174.6	169.3	165.1				
	125	Q	2981	2510	2293	2087	1892	1709	1375	1084				
		P	238.1	230.4	226.7	223.2	219.6	216.0	208.7	200.7				
CSH9573-240	85	Q	3280	3021	2771	2533	2309	1899	1540					
		P	168.8	165.9	162.8	159.6	156.4	150.4	144.6					
	105	Q	3633	3084	2830	2590	2364	2150	1761	1418				
		P	213.9	206.8	203.3	199.8	196.3	192.9	186.3	179.7				
	125	Q	3348	2833	2596	2371	2159	1958	1593	1274				
		P	261.6	253.8	249.9	246.0	242.1	238.2	230.4	222.9				
CSH9583-280	85	Q	3642	3356	3084	2828	2588	2155	1781					
		P	194.3	190.9	187.1	183.4	179.8	174.1	171.7					
	105	Q	4092	3479	3199	2935	2687	2455	2034	1673				
		P	246.1	237.8	233.2	228.6	224.0	219.6	212.3	208.2				
	125	Q	3820	3235	2964	2709	2469	2244	1839	1492				
		P	302.9	291.4	285.3	279.3	273.4	268.0	259.1	253.9				
CSH9593-300	85	Q	4087	3783	3489	3210	2947	2469	2053					
		P	215.0	211.9	208.0	204.0	200.2	194.3	192.0					
	105	Q	4559	3890	3582	3292	3019	2763	2296	1890				
		P	272.8	264.2	259.3	254.3	249.4	244.8	237.2	233.1				
	125	Q	4250	3604	3306	3024	2757	2507	2053	1662				
		P	336.6	324.4	318.0	311.6	305.4	299.6	290.0	284.4				

Performance data for individual input data see BITZER Software.

Données de puissance pour des données d'entrée individuelles voir BITZER Software.

Datos de rendimiento para datos de entrada individuales ver BITZER Software.

① Economiser operation: Performance data with liquid subcooling (t_{cu} = t_{ms} + 10°F)

① Fonctionnement avec économiseur: données de puissance avec sous-refroidissement de liquide (t_{cu} = t_{ms} + 10°F)

① Funcionamiento con economizador: datos de rendimiento con subenfriamiento del liquido (t_{cu} = t_{ms} + 10°F)

! For operation with R22 the oil B320H is required

! Pour le fonctionnement avec R22 il est nécessaire d'utiliser de l'huile B320H

! Para el funcionamiento con R22 es necesario aceite B320H

Additional cooling:
Liquid injection or external oil cooling

Refrigeration additional:
Injection de liquide ou refroidissement d'huile externe

Refrigeración adicional:
Inyección de refrigerante o refrigeración externa del aceite



Performance data 60 Hz

based on 20°F suction superheat,
15°F liquid subcooling

Données de puissance 60 Hz

se référant à surchauffe du gaz aspiré
de 20°F, 15°F sous-refroidissement de
liquide

Datos de rendimiento 60 Hz

sobre la base de un sobrecalentamiento
del gas aspirado de 20°F, 15°F subenfria-
miento del líquido

Compressor type Compresseur type Tipo de compresor	Cond. temp. Temp. de Cond. Temp. de Cond. °F	↓	Cooling capacity Puissance frigorifique Potencia refrigeradora			Q _o	[kBTUH]	Power consumption Puissance absorbée Consumo de potencia			P _e	[kW]			
			Evaporation temperature °F					Température d'évaporation °F					Temperatura de evaporación °F		
			50	40	35			30	25	20			10	0	
CSH6553-50(Y)	90	Q	723	593	536	482	433	388	308	240					
		P	33.5	31.4	30.4	29.6	28.8	28.1	26.8	25.7					
	110	Q	639	519	466	417	372	331	259	198					
		P	40.7	38.7	37.8	36.9	36.1	35.4	34.1	32.9					
	130	Q	537	430	382	338	299	262	199	147					
		P	50.0	48.0	47.1	46.2	45.4	44.7	43.2	41.9					
CSH6563-60(Y)	90	Q	907	744	672	605	543	486	386	301					
		P	41.5	38.9	37.8	36.7	35.7	34.8	33.2	31.9					
	110	Q	802	652	585	524	467	415	324	248					
		P	50.5	48.0	46.9	45.8	44.8	43.9	42.3	40.8					
	130	Q	675	540	480	425	375	330	250	185					
		P	62.1	59.6	58.4	57.4	56.4	55.4	53.7	52.0					
CSH7553-70(Y)	90	Q	1092	887	797	714	637	567	445	344					
		P	48.7	45.8	44.4	43.2	42.1	41.0	39.1	37.5					
	110	Q	946	763	682	608	541	479	372	284					
		P	58.2	55.7	54.6	53.5	52.5	51.6	49.9	48.3					
	130	Q	781	624	555	492	435	383	293	220					
		P	70.7	68.8	67.9	67.1	66.3	65.5	63.9	62.4					
CSH7563-80(Y)	90	Q	1254	1020	916	821	734	653	513	397					
		P	59.0	53.6	51.4	49.4	47.7	46.3	43.9	42.2					
	110	Q	1076	868	777	693	617	547	425	324					
		P	68.4	63.7	61.7	60.1	58.6	57.4	55.3	53.8					
	130	Q	879	704	626	556	492	434	333	250					
		P	80.7	76.9	75.3	74.0	72.9	71.9	70.4	69.3					
CSH7573-90(Y)	90	Q	1421	1161	1046	940	842	752	594	462					
		P	62.9	59.0	57.3	55.8	54.3	53.0	50.7	48.8					
	110	Q	1231	1001	899	805	719	640	501	385					
		P	75.6	72.2	70.6	69.2	67.9	66.6	64.4	62.4					
	130	Q	1017	821	734	654	581	514	397	299					
		P	92.6	89.5	88.1	86.8	85.6	84.4	82.2	80.1					
CSH7583-100(Y)	90	Q	1632	1337	1206	1085	974	872	693	542					
		P	74.2	69.3	67.2	65.2	63.5	61.8	59.0	56.5					
	110	Q	1425	1163	1047	940	841	751	592	460					
		P	87.8	83.8	82.0	80.3	78.8	77.3	74.6	72.3					
	130	Q	1192	966	867	775	691	614	480	369					
		P	106.4	102.9	101.3	99.8	98.3	96.9	94.2	91.5					
CSH7593-110(Y)	90	Q	1863	1525	1375	1237	1110	993	787	615					
		P	87.2	79.8	76.7	74.1	71.8	69.9	66.7	64.2					
	110	Q	1622	1323	1190	1068	956	853	672	521					
		P	102.6	96.3	93.7	91.5	89.5	87.8	84.8	82.3					
	130	Q	1351	1097	984	880	785	698	545	417					
		P	125.6	120.1	117.8	115.8	113.9	112.3	109.3	106.3					
CSH8553-110(Y)	90	Q	1737	1426	1287	1160	1042	934	744	584					
		P	77.8	72.6	70.4	68.4	66.7	65.1	62.5	60.4					
	110	Q	1529	1248	1123	1008	902	805	634	491					
		P	94.5	89.8	87.8	85.9	84.3	82.8	80.1	77.8					
	130	Q	1294	1046	937	836	743	659	510	387					
		P	118.4	113.9	111.9	110.1	108.4	106.8	103.9	101.1					
CSH8563-125(Y)	90	Q	1980	1625	1467	1322	1188	1064	847	665					
		P	88.6	82.8	80.2	78.0	76.0	74.2	71.2	68.9					
	110	Q	1743	1422	1280	1149	1028	918	723	559					
		P	107.7	102.3	100.0	97.9	96.0	94.3	91.3	88.7					
	130	Q	1476	1193	1068	953	848	751	581	440					
		P	134.9	129.8	127.6	125.5	123.6	121.8	118.4	115.3					
CSH8573-140(Y)	90	Q	2286	1875	1693	1525	1370	1228	977	767					
		P	101.2	94.5	91.6	89.1	86.8	84.8	81.3	78.6					
	110	Q	2013	1642	1478	1327	1187	1059	834	646					
		P	123.0	116.9	114.2	111.8	109.7	107.7	104.2	101.3					
	130	Q	1705	1379	1235	1102	980	868	672	509					
		P	154.0	148.2	145.7	143.3	141.1	139.0	135.2	131.6					
CSH8583-160(Y)	90	Q	2525	2063	1857	1668	1494	1334	1052	817					
		P	111.2	105.6	102.9	100.3	97.8	95.4	91.1	87.5					
	110	Q	2240	1820	1633	1462	1304	1159	904	692					
		P	136.4	131.2	128.6	126.2	123.8	121.4	117.2	113.4					
	130	Q	1933	1559	1393	1241	1101	973	748	561					
		P	172.0	167.1	164.6	162.2	159.8	157.5	153.1	149.1					

Performance data 60 Hz

based on 20°F suction superheat,
15°F liquid subcooling

Données de puissance 60 Hz

se référant à surchauffe du gaz aspiré
de 20°F, 15°F sous-refroidissement de
liquide

Datos de rendimiento 60 Hz

sobre la base de un sobrecalentamiento
del gas aspirado de 20°F, 15°F subenfria-
miento del líquido

Compressor type Compresseur type Tipo de compresor	Cond. temp. Temp. de Cond. Temp. de Cond. °F	↓	Cooling capacity Puissance frigorifique Potencia refrigeradora			Q _o	[kBTUH]	Power consumption Puissance absorbée Consumo de potencia			P _e	[kW]			
			Evaporation temperature °F					Température d'évaporation °F					Temperatura de evaporación °F		
			50	40	35			30	25	20			10	0	
CSH8593-180(Y)	90	Q	3014	2461	2215	1989	1781	1590	1254	973					
		P	125.4	119.2	116.2	113.4	110.6	108.0	103.3	99.2					
	110	Q	2684	2178	1954	1748	1559	1385	1080	826					
		P	153.0	147.3	144.5	141.8	139.1	136.6	131.9	127.8					
	130	Q	2325	1873	1673	1490	1321	1167	897	673					
		P	192.1	186.7	184.0	181.4	178.8	176.3	171.5	167.2					
CSH9553-180(Y)	90	Q	3035	2475	2227	1998	1787	1594	1253	969					
		P	116.5	114.8	113.5	111.9	110.1	108.2	104.1	100.3					
	110	Q	2662	2156	1932	1726	1537	1362	1057	802					
		P	146.4	144.8	143.4	141.7	139.7	137.6	133.1	128.5					
	130	Q	2249	1805	1609	1429	1263	1111	846	626					
		P	186.2	183.9	182.2	180.1	177.7	175.1	169.4	163.4					
CSH9563-210(Y)	90	Q	3412	2795	2521	2268	2034	1819	1440	1119					
		P	140.5	134.2	131.4	128.8	126.4	124.2	120.0	116.3					
	110	Q	3006	2448	2200	1972	1761	1567	1225	937					
		P	169.4	164.7	162.5	160.4	158.3	156.3	152.3	148.1					
	130	Q	2551	2062	1845	1645	1461	1293	996	748					
		P	209.6	205.8	203.9	202.0	200.0	197.9	193.3	188.1					
CSH9573-240(Y)	90	Q	4035	3286	2954	2648	2366	2108	1654	1275					
		P	169.5	159.6	155.2	151.2	147.5	144.0	137.9	132.4					
	110	Q	3565	2892	2594	2320	2067	1836	1430	1091					
		P	200.8	192.0	188.1	184.4	181.0	177.9	172.0	166.6					
	130	Q	3060	2470	2210	1970	1750	1548	1194	900					
		P	243.7	235.8	232.2	228.8	225.7	222.6	216.9	211.4					
CSH9583-280(Y)	90	Q	4450	3646	3289	2960	2657	2378	1887	1475					
		P	181.3	175.2	172.1	169.1	166.0	163.0	157.0	151.2					
	110	Q	3991	3250	2921	2618	2340	2084	1634	1258					
		P	225.0	218.5	215.2	211.8	208.4	205.0	198.0	191.0					
	130	Q	3475	2804	2507	2234	1983	1753	1349	1013					
		P	279.7	272.3	268.5	264.5	260.5	256.4	248.0	239.3					
CSH9593-300(Y)	90	Q	5057	4143	3738	3364	3019	2702	2144	1676					
		P	199.8	193.1	189.7	186.3	183.0	179.6	173.0	166.6					
	110	Q	4535	3693	3320	2977	2660	2369	1858	1430					
		P	248.0	240.9	237.2	233.5	229.7	225.9	218.3	210.5					
	130	Q	3949	3187	2851	2541	2256	1994	1535	1152					
		P	308.2	300.1	295.9	291.5	287.1	282.6	273.3	263.7					

Performance data for individual input data see BITZER Software.

Données de puissance pour des données d'entrée individuelles voir BITZER Software.

Datos de rendimiento para datos de entrada individuales ver BITZER Software.

! For operation with R407C polyol-ester oil BSE170 is required

! Pour le fonctionnement avec R407C il est nécessaire d'utiliser de l'huile polyolester BSE170

! Para el funcionamiento con R407C es necesario aceite poliéster BSE170

Additional cooling:
Liquid injection or external oil cooling

Refrroidissement additionnel:
Injection de liquide ou refroidissement d'huile externe

Refrigeración adicional:
Inyección de refrigerante o refrigeración externa del aceite



Performance data 60 Hz
based on 20°F suction superheat ①

Données de puissance 60 Hz
se référant à surchauffe du gaz aspiré
de 20°F ①

Datos de rendimiento 60 Hz
sobre la base de un sobrecalentamiento
del gas aspirado de 20°F ①

Compressor type Compresseur type Tipo de compresor	Cond. temp. Temp. de Cond. Temp. de Cond. °F	↓	Cooling capacity Puissance frigorifique Potencia refrigeradora			Q _o	Power consumption Puissance absorbée Consumo de potencia			P _e			
			Evaporation temperature °F				Température d'évaporation °F				Temperatura de evaporación °F		
			50	40	35		30	25	20		10	0	
CSH6553-50(Y)	85	Q	609	559	512	468	426	350	283				
		P	32.1	31.6	31.0	30.4	29.8	28.7	27.6				
	105	Q	678	571	522	476	433	392	318				
		P	43.0	41.6	40.9	40.2	39.4	38.7	37.2				
125	Q	616	513	466	421	380	341	271					
	P	55.3	53.5	52.6	51.7	50.8	49.8	48.0					
CSH6563-60(Y)	85	Q	750	689	631	576	524	430	347				
		P	38.9	38.3	37.6	37.0	36.3	34.9	33.6				
	105	Q	834	702	642	585	531	481	390				
		P	52.1	50.5	49.6	48.7	47.9	47.0	45.3				
125	Q	756	629	571	516	465	417	331					
	P	66.8	64.8	63.7	62.6	61.5	60.4	58.3					
CSH7553-70(Y)	85	Q	911	832	757	687	621	504	403				
		Q	46.9	46.0	45.2	44.3	43.4	41.7	40.0				
	105	P	1004	837	762	691	625	563	452				
		Q	61.4	59.7	58.8	57.8	56.9	55.9	53.9				
125	P	892	738	668	604	543	487	387					
	Q	77.9	76.1	75.1	74.1	73.0	71.9	69.7					
CSH7563-80(Y)	85	P	1033	944	860	781	707	574	459				
		Q	54.0	52.4	50.9	49.6	48.4	46.3	44.5				
	105	P	1126	940	856	777	703	634	510				
		Q	71.0	67.3	65.7	64.2	62.8	61.6	59.3				
125	P	989	820	744	672	606	544	433					
	Q	87.7	84.2	82.6	81.2	79.8	78.5	76.2					
CSH7573-90(Y)	85	P	1151	1056	965	878	798	651	524				
		Q	57.8	57.0	56.1	55.2	54.2	52.4	50.6				
	105	Q	1261	1061	969	883	802	726	589				
		P	76.3	74.2	73.2	72.1	71.0	69.9	67.6				
125	Q	1118	936	852	773	700	630	505					
	P	97.5	95.2	93.9	92.6	91.3	89.9	87.2					
CSH7583-100(Y)	85	Q	1347	1234	1128	1028	934	765	618				
		P	69.7	68.3	66.9	65.5	64.2	61.5	59.1				
	105	Q	1481	1247	1140	1040	946	858	697				
		P	90.6	87.8	86.3	84.9	83.5	82.0	79.0				
125	Q	1324	1110	1012	919	833	752	607					
	P	114.1	111.1	109.4	107.7	106.0	104.2	100.7					
CSH7593-110(Y)	85	Q	1510	1385	1266	1154	1048	857	691				
		P	78.6	76.6	74.7	73.0	71.4	68.7	66.3				
	105	Q	1657	1396	1276	1164	1058	959	780				
		Q	103.4	98.7	96.7	94.8	93.1	91.4	88.4				
125	P	1475	1238	1129	1027	931	840	678					
	Q	131.0	126.3	124.1	122.1	120.1	118.1	114.4					
CSH8553-110(Y)	85	P	1463	1343	1230	1124	1024	843	684				
		Q	74.5	73.1	71.8	70.5	69.2	66.8	64.6				
	105	P	1622	1370	1254	1146	1044	948	773				
		Q	99.5	96.2	94.6	93.0	91.4	89.9	86.8				
125	P	1478	1240	1131	1028	932	841	677					
	Q	129.5	125.5	123.4	121.4	119.4	117.3	113.3					
CSH8563-125(Y)	85	P	1640	1507	1380	1261	1149	946	768				
		Q	83.1	81.7	80.2	78.8	77.5	75.0	72.6				
	105	P	1817	1535	1406	1285	1170	1063	868				
		Q	110.9	107.4	105.7	104.0	102.4	100.7	97.5				
125	Q	1654	1389	1267	1152	1044	943	759					
	P	144.5	140.2	138.1	136.0	133.8	131.6	127.3					
CSH8573-140(Y)	85	Q	1856	1707	1565	1431	1304	1074	872				
		P	92.6	91.2	89.7	88.3	86.8	84.2	81.7				
	105	Q	2057	1739	1594	1456	1327	1206	985				
		P	123.7	120.0	118.2	116.4	114.7	113.0	109.6				
125	Q	1872	1573	1435	1306	1184	1069	861					
	P	161.2	156.8	154.6	152.3	150.1	147.8	143.2					
CSH8583-160(Y)	85	Q	2076	1899	1733	1576	1430	1165	934				
		P	105.7	104.3	102.7	101.0	99.1	95.4	91.8				
	105	Q	2316	1942	1772	1611	1461	1320	1064				
		P	139.7	136.7	134.9	132.9	130.7	128.5	123.8				
125	Q	2123	1770	1608	1456	1313	1179	940					
	P	182.2	178.1	175.7	173.0	170.3	167.5	161.9					

Performance data 60 Hz

based on 20°F suction superheat ①

Données de puissance 60 Hz

se référant à surchauffe du gaz aspiré de 20°F ①

Datos de rendimiento 60 Hz

sobre la base de un sobrecalentamiento del gas aspirado de 20°F ①

Compressor type Compresseur type Tipo de compresor	Cond. temp. Temp. de Cond. Temp. de Cond. °F	↓	Cooling capacity Puissance frigorifique Potencia refrigeradora			Q _o	Power consumption Puissance absorbée Consumo de potencia			P _e	[kW]			
			Evaporation temperature °F				Température d'évaporation °F					Temperatura de evaporación °F		
			50	40	35		30	25	20			10	0	
CSH8593-180(Y)	85	Q	2436	2230	2035	1851	1678	1366	1096					
		P	117.2	115.9	114.3	112.5	110.6	106.6	102.8					
	105	Q	2727	2285	2083	1894	1716	1550	1248	987				
		P	154.0	151.0	149.1	147.0	144.8	142.5	137.6	132.8				
	125	Q	2503	2083	1891	1711	1542	1384	1101	861				
		P	199.8	195.7	193.3	190.6	187.7	184.8	179.0	173.6				
CSH9553-180(Y)	85	Q	2526	2306	2099	1905	1724	1397	1113					
		P	116.8	116.6	116.0	114.9	113.4	109.7	105.6					
	105	Q	2791	2330	2119	1922	1737	1563	1250	981				
		P	152.3	152.7	151.9	150.6	148.8	146.6	141.5	136.1				
	125	Q	2503	2071	1874	1689	1517	1357	1073	830				
		P	200.3	198.6	196.7	194.3	191.5	188.4	181.7	174.8				
CSH9563-210(Y)	85	Q	2808	2571	2347	2136	1939	1581	1267					
		P	134.6	133.2	131.7	130.1	128.4	124.8	124.8	120.9				
	105	Q	3102	2603	2375	2160	1959	1769	1424	1125				
		P	174.0	171.7	170.2	168.6	166.7	164.7	160.0	155.0				
	125	Q	2791	2325	2111	1910	1722	1547	1233	964				
		P	222.9	219.8	217.8	215.5	213.0	210.3	204.5	198.2				
CSH9573-240(Y)	85	Q	3253	2971	2702	2450	2214	1789	1421					
		P	157.3	154.9	152.3	149.7	147.1	141.8	141.8	136.6				
	105	Q	3618	3022	2751	2496	2258	2034	1630	1282				
		P	202.9	197.2	194.3	191.4	188.4	185.4	179.2	172.9				
	125	Q	3276	2724	2471	2234	2012	1805	1437	1125				
		P	254.4	247.8	244.3	240.7	237.0	233.4	226.4	219.7				
CSH9583-280(Y)	85	Q	3639	3326	3032	2757	2500	2035	1631					
		P	173.6	172.4	170.7	168.8	166.5	161.3	161.3	155.4				
	105	Q	4065	3398	3095	2810	2543	2292	1842	1458				
		P	227.9	224.5	222.1	219.3	216.2	212.7	205.0	197.2				
	125	Q	3705	3065	2775	2503	2251	2018	1606	1254				
		P	291.8	285.2	281.2	276.9	272.4	267.8	258.5	248.9				
CSH9593-300(Y)	85	Q	4073	3728	3401	3093	2805	2285	1834					
		P	187.7	186.9	185.3	183.4	181.2	175.9	175.9	169.7				
	105	Q	4553	3808	3470	3152	2854	2575	2070	1638				
		P	246.9	243.7	241.4	238.7	235.5	232.0	224.0	215.6				
	125	Q	4151	3440	3115	2811	2528	2266	1800	1405				
		P	317.0	310.6	306.5	302.1	297.3	292.4	282.4	272.1				

Performance data for individual input data see BITZER Software.

① Economiser operation: Performance data with liquid subcooling ($t_{cu} = t_{ms} + 10^\circ\text{F}$)

! For operation with R407C polyol-ester oil BSE170 is required

Additional cooling:
Liquid injection or external oil cooling

Données de puissance pour des données d'entrée individuelles voir BITZER Software.

① Fonctionnement avec économiseur: données de puissance avec sous-refroidissement de liquide ($t_{cu} = t_{ms} + 10^\circ\text{F}$)

! Pour le fonctionnement avec R407C il est nécessaire d'utiliser de l'huile polyolester BSE170

Refrroidissement additionnel:
Injection de liquide ou refroidissement d'huile externe

Datos de rendimiento para datos de entrada individuales ver BITZER Software.

① Funcionamiento con economizador: datos de rendimiento con subenfriamiento del líquido ($t_{cu} = t_{ms} + 10^\circ\text{F}$)

! Para el funcionamiento con R407C es necesario aceite poliéster BSE170

Refrigeración adicional:
Inyección de refrigerante o refrigeración externa del aceite



Technical data

Caractéristiques techniques

Datos técnicos

Compressor type	Motor version	Displacement 60 Hz	Oil charge	Weight	Pipe connections		Capacity control	Motor connection	Max. operating current	Max. power consum.	Starting current (locked rotor)	
					Discharge line inch mm	Suction line inch mm						
Compresseur type	Version moteur	Volume balayé 60 Hz	Charge d'huile	Poids	Raccords		Régulation de puiss.	Raccordement de moteur	Courant de service max.	Puissance absorbée max.	Courant de démarrage (rotor bloqué)	
Compresor tipo	Versión motor	Volumen desplazado 60 Hz	Carga de aceite	Peso	Conexiones tubería		Regulación potencia	Conexión motor	Corriente servicio máxima	Consumo potencia máximo	Corriente arranque (rotor bloqueado)	
①	②	CFH ^③	fl. oz	lbs ^④	Conducto de presión pulgada mm	Conducto de aspiración pulgada mm	% ^⑤		A ^⑥	kW ^⑦	A Δ/ΔΔ ^⑧	
CSH6553-35Y CSH6553-50(Y)	2 1	5830	334	692 710	1 ⁵ / ₈ " 42	2 ¹ / ₈ " 54	100 ↕ 25	460V(±10%) Δ-3-60Hz 400V(±10%) Δ-3-50Hz Y/Δ ^⑨	58 86	41 63	153/305 218/411	
CSH6563-40Y CSH6563-60(Y)	2 1	7240	334	692 710	1 ⁵ / ₈ " 42	2 ¹ / ₈ " 54			66 108	50 79	182/338 269/508	
CSH6583-50Y	2	8334	352	805	2 ¹ / ₈ " 54	2 ⁵ / ₈ " 64			82	64	146/438	
CSH6593-60Y	2	9394	352	805	2 ¹ / ₈ " 54	2 ⁵ / ₈ " 64			105	71	180/540	
CSH7553-50Y CSH7553-70(Y)	2 1	8405	528	1103 1136	2 ¹ / ₈ " 54	3 ¹ / ₈ " 76			79 128	63 94	206/355 290/485	
CSH7563-60Y CSH7563-80(Y)	2 1	9676	528	1125 1147	2 ¹ / ₈ " 54	3 ¹ / ₈ " 76			98 144	79 106	267/449 350/585	
CSH7573-70Y CSH7573-90(Y)	2 1	10983	528	1136 1169	2 ¹ / ₈ " 54	3 ¹ / ₈ " 76			124 162	94 116	290/485 423/686	
CSH7583-80Y CSH7583-100(Y)	2 1	12572	528	1158 1158	2 ¹ / ₈ " 54	3 ¹ / ₈ " 76			144 170	106 122	350/585 479/790	
CSH7593-90Y CSH7593-110(Y)	2 1	14338	528	1169 1169	2 ¹ / ₈ " 54	3 ¹ / ₈ " 76			162 180	116 135	423/686 516/887	
CSH8553-80Y CSH8553-110(Y)	2 1	13420	774	1830 1852	3 ¹ / ₈ " 76	DN 100			or / ou / o	144 180	106 133	394/606 520/801
CSH8563-90Y CSH8563-125(Y)	2 1	15291	774	1830 1874	3 ¹ / ₈ " 76	DN 100			100 ^⑩	155 216	116 160	439/675 612/943
CSH8573-110Y CSH8573-140(Y)	2 1	17481	774	1852 1896	3 ¹ / ₈ " 76	DN 100			75	182 246	133 181	520/801 665/1023
CSH8583-125Y CSH8583-160(Y)	2 1	20024	669	1874 1874	3 ¹ / ₈ " 76	DN 100			50	196 260	145 193	612/943 729/1114
CSH8593-140Y CSH8593-180(Y)	2 1	22814	669	1896 1896	3 ¹ / ₈ " 76	DN 100			25	214 310	158 225	665/1023 602/1181
CSH9553-180(Y)	1	22814	1056	2822	3 ¹ / ₈ " 76	DN 100			460V(±10%) Δ/ΔΔ-3-60Hz 400V(±10%) Δ/ΔΔ-3-50Hz Part Winding	330	248	465/1442
CSH9563-160Y CSH9563-210(Y)	2 1	26204	1056	2800 2867	3 ¹ / ₈ " 76	DN 100				280 370	187 297	436/1364 586/1853
CSH9573-180Y CSH9573-240(Y)	2 1	29841	1056	2822 2889	3 ¹ / ₈ " 76	DN 100	310 420	211 308		465/1442 650/2029		
CSH9583-210Y CSH9583-280(Y)	2 1	34326	1056	2933 3000	DN 100	DN 125	320 450	246 338		586/1853 805/2520		
CSH9593-240Y CSH9593-300(Y)	2 1	38776	1056	2977 3043	DN 100	DN 125	360 450	268 338		650/2029 805/2520		
CSH95103-280Y	2	43261	1126	3197	DN 100	DN 125	413	307		805/2520		

Data for accessories and oil charge

- Oil heater 200 .. 230 V
CSH65: 200 W
CSH75: 200 W
CSH85: 300 W
CSH95: 300 W
- Capacity control
230V/50/60Hz
- Oil charge
Type BSE170 for R134a and R407C
Type B320SH for R22

Oil heater

ensures the lubricity of the oil even after long standstill periods. It prevents increased refrigerant solution in the oil and therefore a reduction of the viscosity.

The oil heater must be used during standstill in case of

- outdoor installation of the compressor
- long shut-off periods
- high refrigerant charge
- danger of refrigerant condensation into the compressor

- ① Supplement "Y" with ester oil charge BSE170 for R134a and R407C (R404A)
- ② See "Application limits"
- ③ 3500 min⁻¹ 60 Hz
- ④ Weight including suction flange, discharge flange and brazed bushings.
Discharge shut-off valve (optional):
Ø 1⁵/₈" (42 mm): 7 lbs
Ø 2¹/₈" (54 mm): 11 lbs
Ø 3¹/₈" (76 mm): 22 lbs
DN 100: 44 lbs
Suction shut-off valve (optional):
Ø 2¹/₈" (54 mm): 11 lbs
Ø 2⁵/₈" (64 mm): 22 lbs
Ø 3¹/₈" (76 mm): 22 lbs
DN 100: 44 lbs
DN 125: 110 lbs
- ⑤ Infinite or alternatively 4-step capacity control
- ⑥ For the selection of contactors, cables and fuses the max. operating current must be considered.
Contactors: operational category AC3.
PW: Select both motor contactors for approx. 60% of the maximum operating current.
Y/Δ: Select the contactors according to contactor manufacturers' instructions (consider the maximum operating current).
- ⑦ CSH65 .. CSH85: data for Δ/ΔΔ (part winding) – Y/Δ version upon request
CSH95: data for Y/Δ
- ⑧ Effective capacity steps are depending upon the operating conditions

Données pour accessoires et charge d'huile

- Chauffage d'huile 200 .. 230 V
CSH65: 200 W
CSH75: 200 W
CSH85: 300 W
CSH95: 300 W
- Régulation de puissance
230V/50/60Hz
- Charge d'huile
Type BSE170 pour R134a et R407C
Type B320SH pour R22

Chauffage d'huile

garantit le pouvoir lubrifiant de l'huile, même après des longues périodes stationnaires. Elle permet d'éviter un enrichissement de l'huile en fluide frigorigène et par conséquent, une baisse de la viscosité.

Le chauffage d'huile doit être utilisé durant des périodes stationnaires

- en cas d'installation extérieure du compresseur
- en cas de longues périodes d'immobilisation
- en cas de haute charge de fluide frigorigène
- en cas de risque de condensation de fluide frigorigène dans le compresseur

- ① Indice "Y" pour charge d'huile ester BSE170 pour R134a et R407C (R404A)
- ② Voir "Limites d'application"
- ③ 3500 min⁻¹ 60 Hz
- ④ Poids y compris bride d'aspiration, bride de pression et manchons à braser.
Vanne d'arrêt au refoulement (option):
Ø 1⁵/₈" (42 mm): 7 lbs
Ø 2¹/₈" (54 mm): 11 lbs
Ø 3¹/₈" (76 mm): 22 lbs
DN 100: 44 lbs
Vanne d'arrêt à l'aspiration (option):
Ø 2¹/₈" (54 mm): 11 lbs
Ø 2⁵/₈" (64 mm): 22 lbs
Ø 3¹/₈" (76 mm): 22 lbs
DN 100: 44 lbs
DN 125: 110 lbs
- ⑤ Régulation de puissance en continu ou alternatif à 4 étages
- ⑥ Pour la sélection des contacteurs, des câbles d'alimentation et des fusibles tenir compte du courant de service max.
Contacteurs: catégorie d'utilisation AC3.
PW: Sélectionner les deux contacteurs du moteur à environ 60% du courant de service maximal.
Y/Δ: Sélectionner les contacteurs en respectant les instructions du fabricant (tenir compte du courant de service maximal).
- ⑦ CSH65 .. CSH85: données pour Δ/ΔΔ (bobinage partiel) – version Y/Δ sur demande
CSH95: données pour Y/Δ
- ⑧ Les étages de puissance effectifs dépendent des conditions de fonctionnement

Datos de los accesorios y la carga de aceite

- Calefacción de aceite 200 .. 230 V
CSH65: 200 W
CSH75: 200 W
CSH85: 300 W
CSH95: 300 W
- Regulador de potencia
230V/50/60Hz
- Carga de aceite
Type BSE170 para R134a y R407C
Tipo B320SH para R22

Calefacción de aceite

garantiza la adecuada lubricación del aceite incluso después de paradas prolongadas. Impide que una acumulación de refrigerante en el aceite y con ello una reducción de la viscosidad.

La calefacción de aceite debe ser usada cuando el compresor no está funcionando

- en caso de que el compresor esté instalado al aire libre
- en caso de una parada prolongada
- si hay mucha carga de refrigerante
- si hay riesgo de que el refrigerante se condense en el compresor

- ① Aditivo "Y" para aceite poliolester BSE170 para R134a y R407C (R404A)
- ② Ver los "Límites de aplicación"
- ③ 3500 min⁻¹ 60 Hz
- ④ Peso con brida de aspiración, brida de presión y manguitos para soldar.
Válvula de cierre de presión (opción):
Ø 1⁵/₈" (42 mm): 7 lbs
Ø 2¹/₈" (54 mm): 11 lbs
Ø 3¹/₈" (76 mm): 22 lbs
DN 100: 44 lbs
Válvula de cierre de aspiración (opción):
Ø 2¹/₈" (54 mm): 11 lbs
Ø 2⁵/₈" (64 mm): 22 lbs
Ø 3¹/₈" (76 mm): 22 lbs
DN 100: 44 lbs
DN 125: 110 lbs
- ⑤ Regulación de potencia continua o en 4 fases
- ⑥ Para seleccionar los contactores, cables de alimentación y fusibles hay que considerar la corriente de servicio máxima
Contactores: categoría de utilización AC3.
PW: seleccionar ambos contactores del motor para aproximadamente 60% de la corriente de servicio máxima
Y/Δ: Seleccionar los contactores siguiendo las indicaciones del fabricante (considerar la corriente de servicio máxima).
- ⑦ CSH65 .. CSH85: datos para Δ/ΔΔ (bobinado parcial) – versión Y/Δ por encargo
CSH95: Datos para Y/Δ
- ⑧ Las etapas de potencia efectivas dependen de las condiciones de servicio

Dimensional drawings

Croquis cotés

Dibujos acotados

CSH65

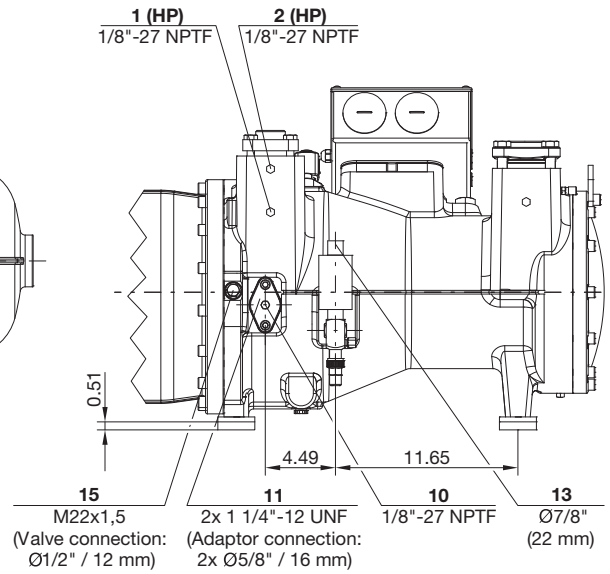
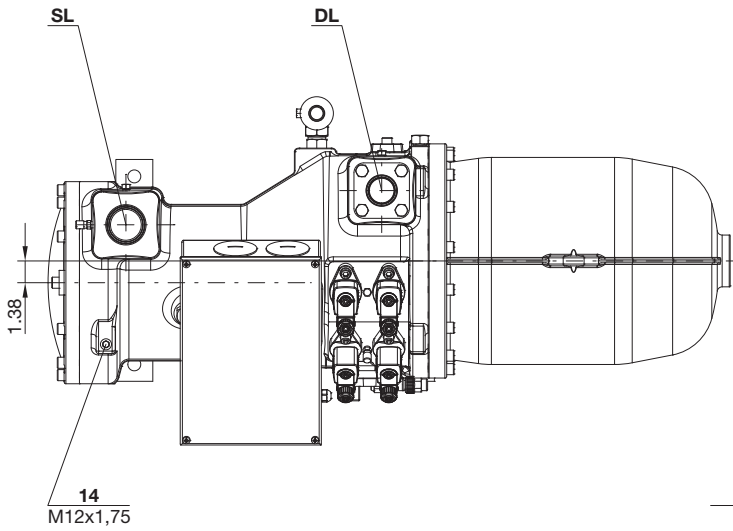
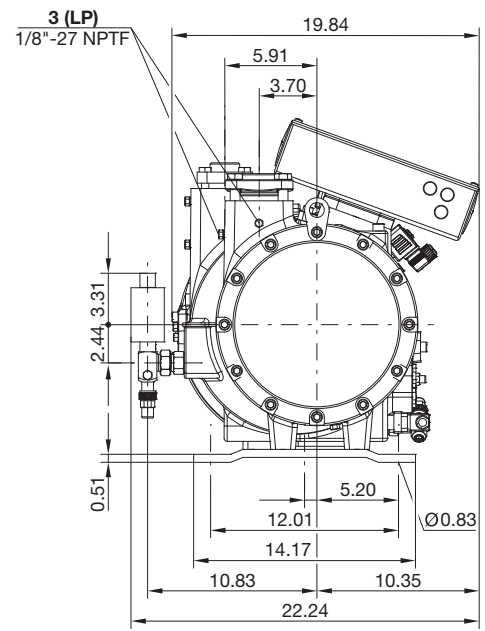
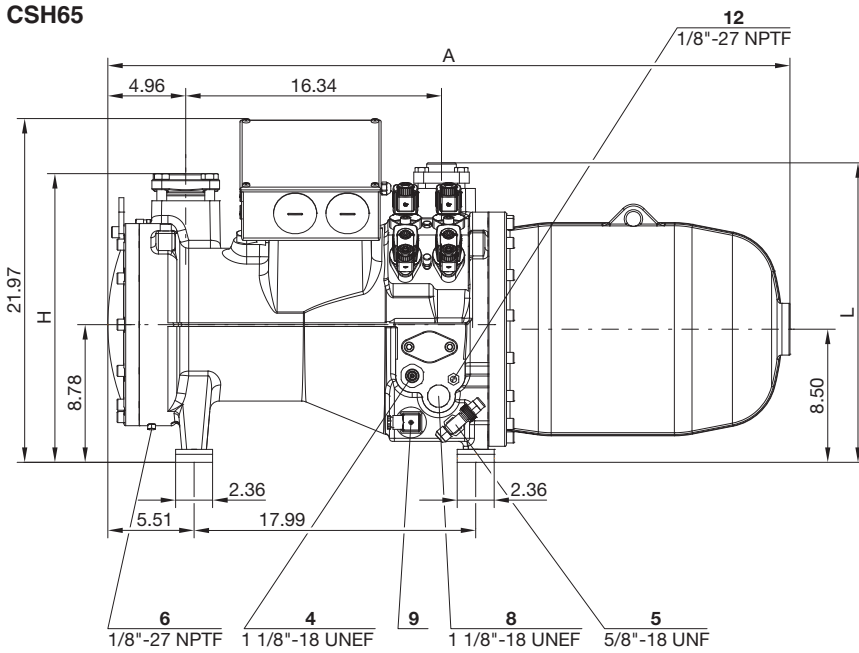

	A	H	L
	inch	inch	inch
CSH6553 CSH6563	43.58	18.42	19.13
CSH6583 CSH6593	47.52	18.82	18.99

M12 and M22: metric screws

M12 et M22: vis métriques

M12 y M22: tornillos métricos

Drawing with optional ECO shut-off valve (position 13)

Représentation avec vanne d'arrêt d'ECO optionale (position 13)

Representación con válvula de cierre ECO opcional (posición 13)

Connection positions see page 28

Position des raccords voir page 28

Posiciones de conexión ver en página 28

Dimensional drawings

Croquis cotés

Dibujos acotados

CSH75

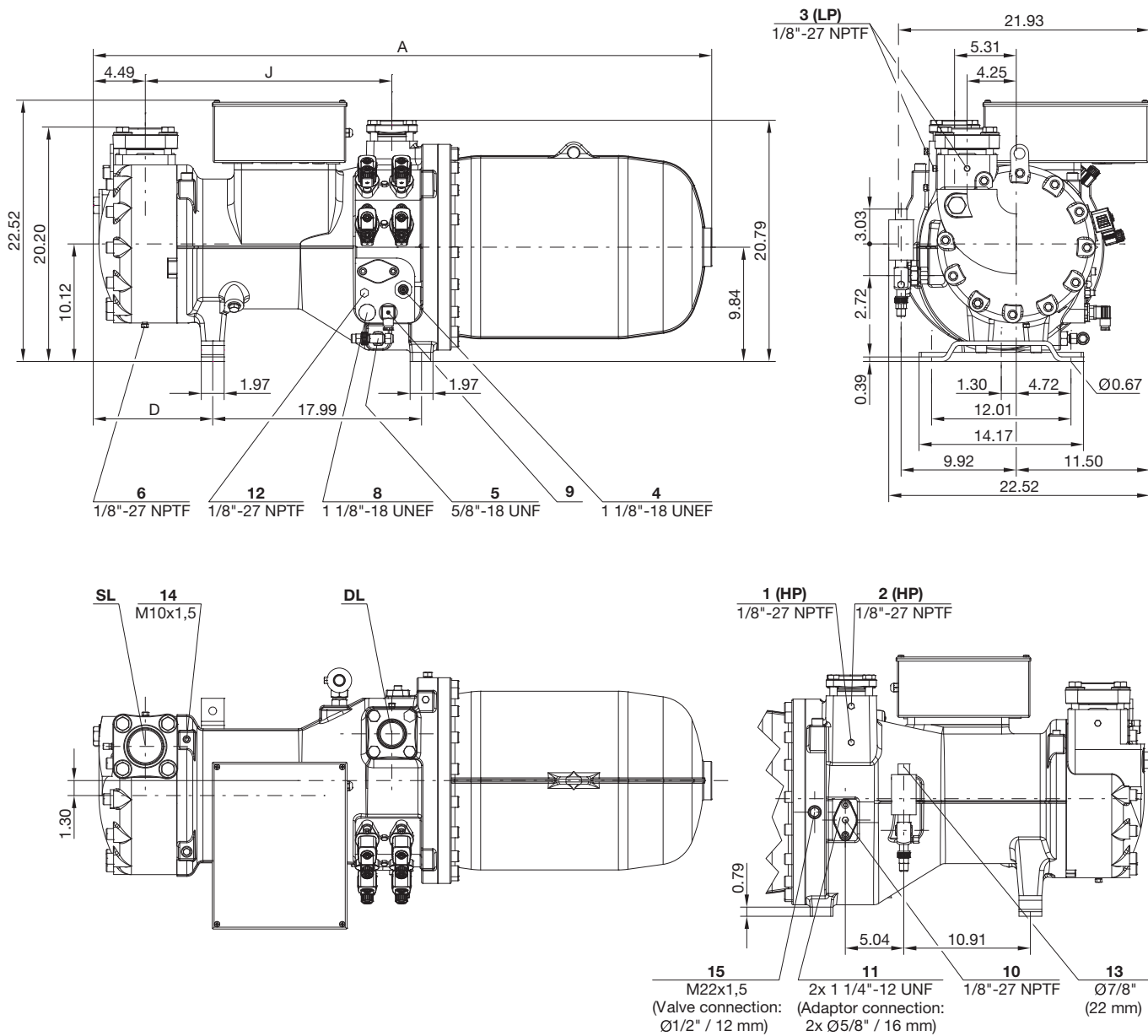

	A	D	J
	inch	inch	inch
CSH7553 / CSH7563 / CSH7573 / CSH7583-80Y / CSH7593-90Y	53.26	10.27	21.25
CSH7583-100(Y) / CSH7593-110(Y)	54.44	11.45	22.44

M10 and M22: metric screws

M10 et M22: vis métriques

M10 y M22: tornillos métricos

Drawing with optional ECO shut-off valve (position 13)

Représentation avec vanne d'arrêt d'ECO optionale (position 13)

Representación con válvula de cierre ECO opcional (posición 13)

Connection positions see page 28

Position des raccords voir page 28

Posiciones de conexión ver en página 28

Dimensional drawings

Croquis cotés

Dibujos acotados

CSH85

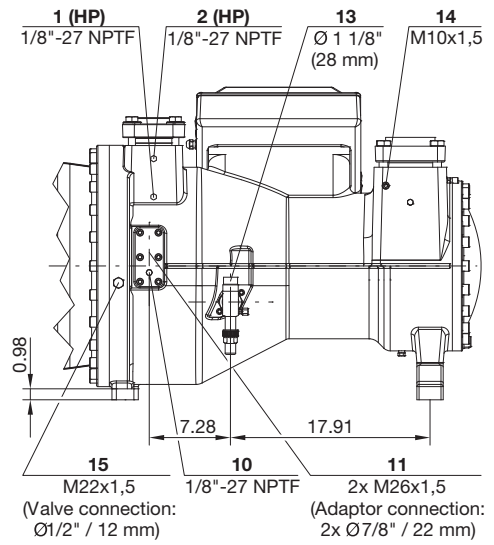
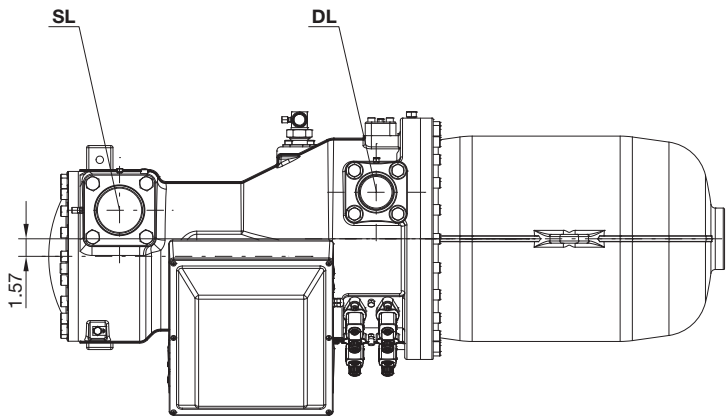
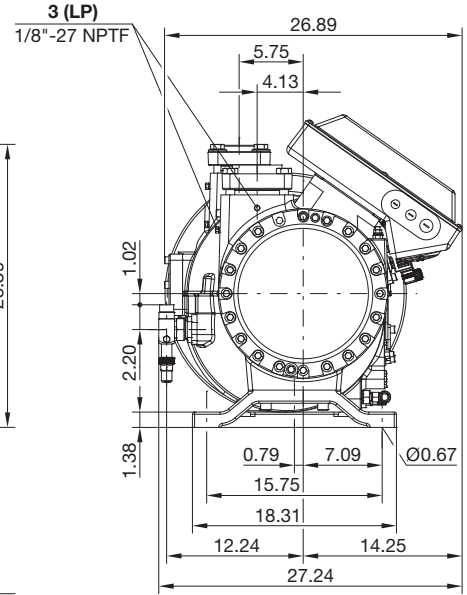
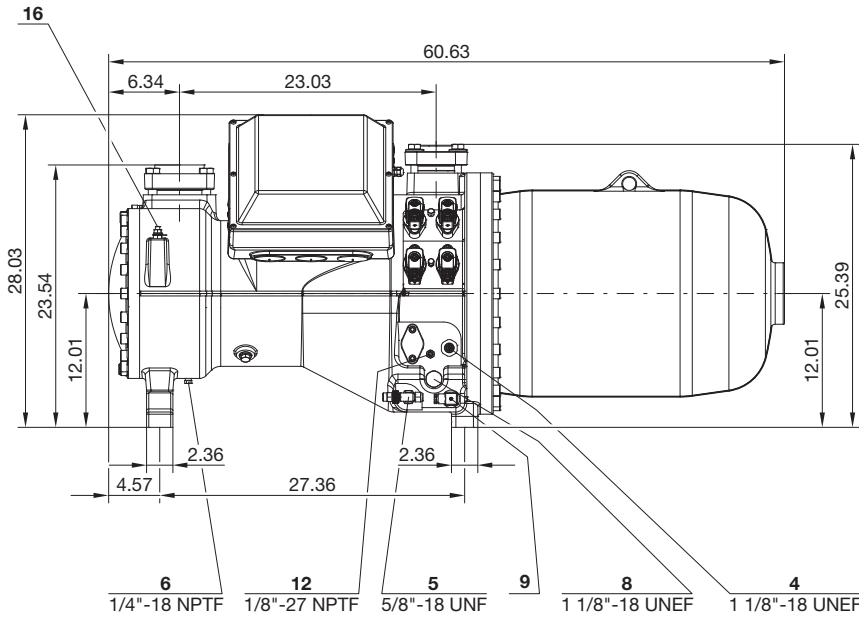

M10, M22 and M26: metric screws

M10, M22 et M26: vis métriques

M10, M22 y M26: tornillos métricos

Drawing with optional ECO shut-off valve (position 13)

Représentation avec vanne d'arrêt d'ECO optionale (position 13)

Representación con válvula de cierre ECO opcional (posición 13)

Connection positions see page 28

Position des raccords voir page 28

Posiciones de conexión ver en página 28

Dimensional drawings

Croquis cotés

Dibujos acotados

CSH95

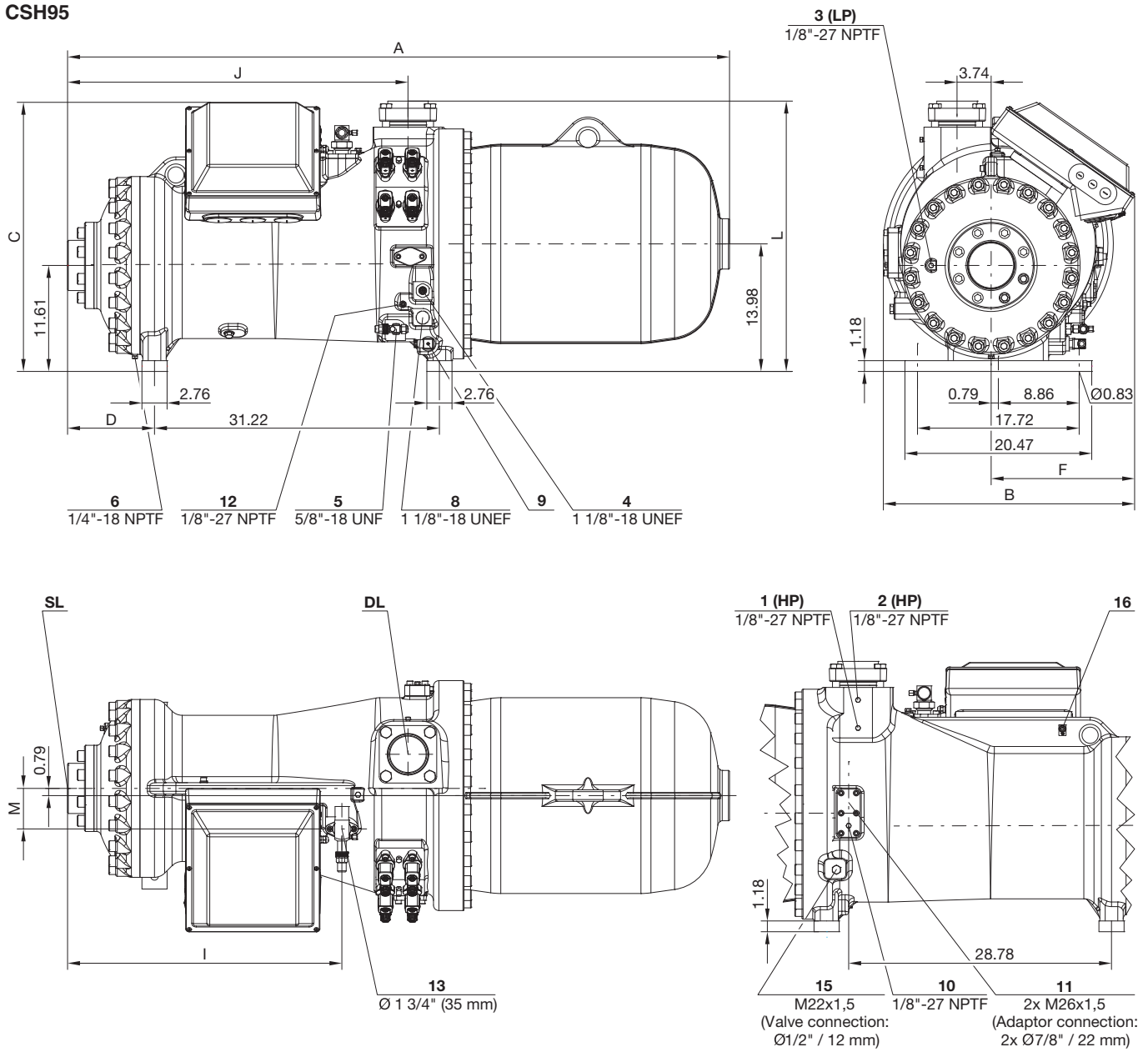

	A inch	B inch	C inch	D inch	F inch	I inch	J inch	L inch	M inch
CSH9553 / CSH9563 / CSH9573	71.81	27.52	29.49	8.82	15.71	29.33	36.57	29.21	4.17
CSH9583-210Y / CSH9593-240Y	72.52	27.52	29.49	9.52	15.71	30.38	37.32	29.60	4.45
CSH9583-280(Y) / CSH9593-300(Y)	73.58	27.52	29.49	10.60	15.71	31.14	38.38	29.60	4.45
CSH95103-280Y	76.97	29.76	32.32	10.60	17.95	31.14	38.38	29.84	4.45
CSH95103-320(Y)	77.75	29.76	32.32	11.38	17.95	31.89	39.17	29.84	4.45

M22 and M26: metric screws

M22 et M26: vis métriques

M22 y M26: tornillos métricos

Drawing with optional ECO shut-off valve (position 13)

Représentation avec vanne d'arrêt d'ECO optionale (position 13)

Representación con válvula de cierre ECO opcional (posición 13)

Connection positions see page 28

Position des raccords voir page 28

Posiciones de conexión ver en página 28

2D drawings in DXF format,
3D drawings in STP format

- are part of the BITZER Software CD-ROM
- can be downloaded from the web site:
 - www.bitzer.de
 - www.bitzer-corp.com
 - web sites of local BITZER subsidiaries

2D dessins en forme DXF,
3D dessins en forme STP

- sont contenus dans le CD-ROM du BITZER Software
- peuvent être téléchargés du page web:
 - www.bitzer.fr
 - www.bitzer-corp.com
 - pages web des BITZER filiales dans locations différentes

Diseños 2D en formato DXF,
diseños 3D en formato STP

- se encuentran en el CD-ROM del BITZER Software
- pueden descargarse de la página web:
 - www.bitzer.de
 - www.bitzer-corp.com
 - páginas web de las empresas filiales de BITZER

Connection positions

- 1 High pressure connection (HP)
- 2 Additional high pressure connection
- 3 Low pressure connection (LP)
- 4 Oil sight glass
- 5 Oil service valve (standard) / connection for oil equalisation (parallel operation)
- 6 Oil drain plug (motor housing)
- 8 Connection for opto-electronical oil level switch OLC-D1-S (optional)
- 9 Oil heater with sleeve (standard)
- 10 Oil pressure connection
- 11 External oil cooler connections (adaptor with control valve optional)
- 12 Oil temperature sensor (PTC)
- 13 Economiser connection (ECO) (shut-off valve with pulsation muffler optional)
- 14 Threaded hole for pipe support (ECO or LI line)
- 15 Liquid injection connection (LI) (shut-off valve optional)
- 16 Grounding screw for housing

SL Suction gas line
DL Discharge gas line

Position des raccords

- 1 Raccord de haute pression (HP)
- 2 Raccord additionnel de haute pression
- 3 Raccord de basse pression (LP)
- 4 Voyant d'huile
- 5 Vanne de service d'huile (standard) / raccord pour égalisation d'huile (fonctionnement en parallèle)
- 6 Bouchon de vidange d'huile (carter moteur)
- 8 Raccord pour contrôleur de niveau d'huile opto-électronique OLC-D1-S (facultatif)
- 9 Chauffage d'huile avec doigt de gant (standard)
- 10 Raccord pression d'huile
- 11 Raccords pour refroidisseur d'huile externe (adaptateur ou vanne de commande facultatif)
- 12 Sonde de température d'huile (CTP)
- 13 Raccord pour économiseur (ECO) (vanne d'arrêt avec amortisseur de pulsations facultative)
- 14 Filetage pour support de tuyauterie (tuyauterie ECO ou LI)
- 15 Raccord pour injection de liquide (LI) (vanne d'arrêt facultative)
- 16 Vis de mise à la terre pour carter

SL Conduite du gaz aspiré
DL Conduite du gaz de refoulement

Posiciones de conexión

- 1 Conexión de alta presión (HP)
- 2 Conexión de alta presión adicional
- 3 Conexión de baja presión (LP)
- 4 Visor del aceite
- 5 Válvula de servicio de aceite (estándar) / conexión para equilibrado de aceite (funcionamiento en paralelo)
- 6 Tapón de drenaje de aceite (cárter del motor)
- 8 Controlador de nivel de aceite (opción)
- 9 Calefacción de aceite con manguito de inmersión (estándar)
- 10 Conexión de presión de aceite
- 11 Conexiones para refrigerador externo del aceite (adaptador con válvula de mando opcional)
- 12 Sensor de temperatura de aceite (CPT)
- 13 Conexión para economizador (válvula de cierre con amortiguador de pulsaciones opcional)
- 14 Rosca para el soporte de la tubería (tubería ECO y LI)
- 15 Conexión para inyección integrada (adaptador opcional)
- 16 Tornillo de puesta a tierra por cárter

SL Conducto de gas aspirado
DL Conducto de gas comprimido

Notes

A large grid of small green dots arranged in a regular pattern, intended for taking notes.



Notes

Grid of dots for notes

Notes

A large grid of green dots for taking notes, consisting of 20 columns and 30 rows.

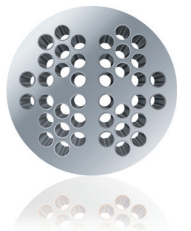



BITZER Kühlmaschinenbau GmbH
Eschenbrünnelestraße 15 // 71065 Sindelfingen // Germany
Tel +49 [0]70 31 932-0 // Fax +49 [0]70 31 932-147
bitzer@bitzer.de // www.bitzer.de