

Serie doble aspiración con motor incorporado

Double inlet series with direct drive motor

Série double aspiration avec moteur incorporé

TMD

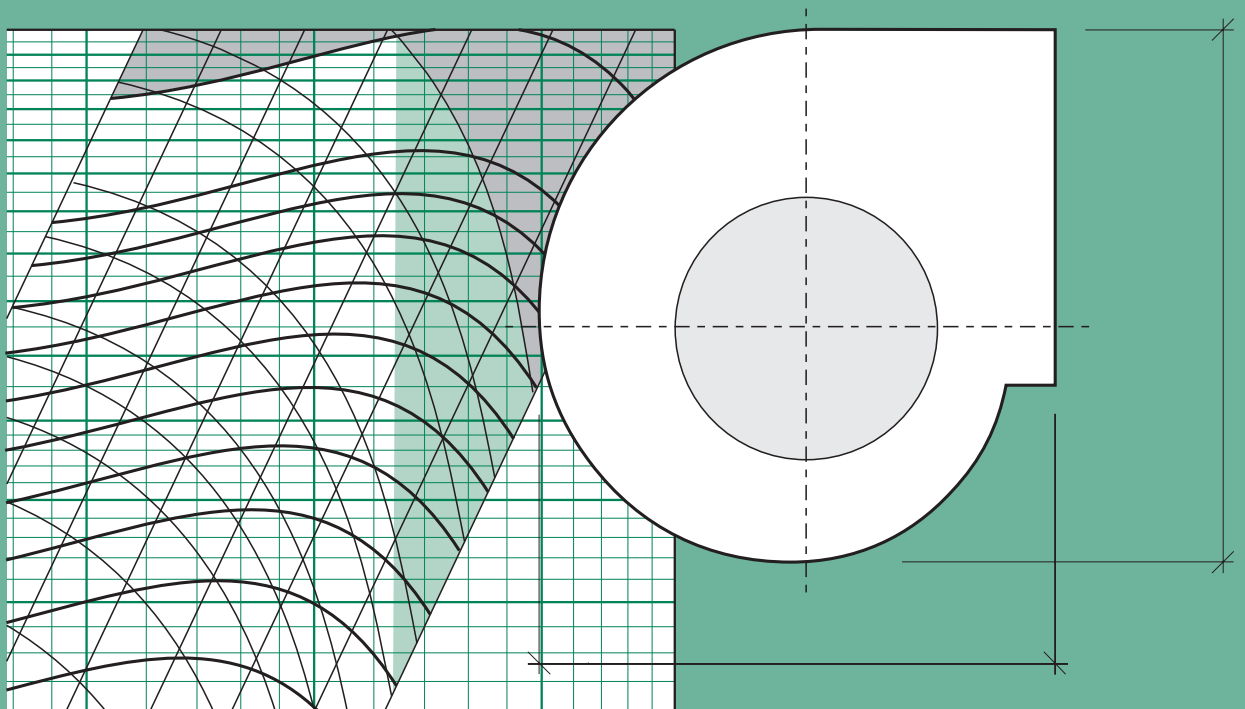

Dimensiones y curvas características

Dimensions and characteristics curves

Dimensions et courbes caractéristiques

Gama de Fabricación

Se compone de una sola familia, de simple rodete, denominada TMD. Se fabrica en nueve tamaños, del 5/8 al 15/15.

Características constructivas

Siendo esta familia perteneciente a la serie ligera descrita anteriormente, destacaremos únicamente los aspectos inherentes a esta

Montaje del motor

La forma de acoplamiento del motor es la siguiente.

Por un lado, el eje del motor está directamente fijado al rodete mediante el moyú de fijación

Por otra parte, el motor está fijado por unos soportes de diseño especial al lateral de la carcasa mediante tornillos, intercalando entre motor y soporte amortiguadores de caucho natural.

Motor eléctrico

Es del tipo abierto (IP20) ó cerrado (IP54), monofásico 220 V, 50 Hz, con condensador, de cuatro o seis polos, de una velocidad con termostato de protección interna, clase de aislamiento F.

En los modelos 10/10, 12/9, 12/12 y 15/15 se monta también con motor trifásico 220/380 V, 50 Hz, de seis polos y una velocidad.

Condensador

Es del tipo de polipropileno, con carcasa de protección en material plástico autoextinguible. Responde a las normas VDE.

Una caperuza asegura la protección de los terminales del condensador

Va sujeto al lateral del ventilador mediante abrazadera.

Conexión eléctrico

El conexionado se efectúa a partir de unas clemas previstas a tal efecto, protegidas por una tapa de plástico.

Recomendaciones para su correcta utilización

Asegurar una buena entrada de aire por el oído que lleva el motor, de manera a evitar un posible calentamiento de este último

Respetar las intensidades límite indicadas por el fabricante del motor y que figuran en la placa de características del mismo

No utilizar el ventilador con descarga libre ya que entonces se produciría un importante aumento del consumo del motor.

El ventilador no debe trabajar con aire o en ambiente cuya temperatura sobrepase los 45° C.

Variantes constructivas

Bajo pedido se pueden estudiar series de ventiladores con las siguientes opciones.

- Motor de 3 velocidades.
- Variador de velocidad.



Production Range

Comprises only one family, simple impeller, called TMD. Available in nine sizes, from 5/8 to 15/15.

Construction features

As this family belongs to the light series, described above, we shall only stress its individual aspects.

Motor assembly

The motor is coupled as follows:

On one side, the motor shaft is coupled direct to the middle plate of the impeller through the hub.

On the other hand, the motor is secured with a specially designed bracket, to the suction inlet. This bracket is fixed to it through screws, enabling the motor to be dismantled.

A rubber shock absorber is inserted between the motor and the bracket.

Motor

It is the open, single phase (IP20) or closed (IP54) class F, 220 V, 50 Hz, type, with capacitor, 4 or 6 poles, one speed and internal protection by thermostat.

In models 10/10, 12/9, 12/12 y 15/15 a three-phase 220/380 V, 50 Hz, motor can be coupled with 6 poles and 1 speed, class F.

Capacitor

It is polypropylene type, with plastic protection housing, and meets standard VDE.

A rubber cap ensures protection of the capacitor terminals. This is fitted to the side of the fan through a screw.

Electric connection

It is connected through some wire clamps provided for this purpose, and with a plastic protection.

For three-phase motors, the respective wiring diagram is given on the fan.

Recommendations for using it correctly

Ensure good flow air through the inlet which the motor has, to avoid the latter heating.

Respect the limit speeds indicated by the motor manufacturer and which are given in its name plate.

Do not use the fan with free discharge, as otherwise there would be a considerable increase in consumption of the motor.

The fan must not work with air or in an atmosphere with a temperature over 45° C.

Construction variations

On order, series of fans can be studied with the following options:

- 3 speed motor.
- Speed variator.

Gamme de Fabrication

Elle se compose d'un seul groupe, d'une seule turbine, appelée TMD. Il existe 9 modèles, du 5/8 au 15/15.

Caractéristiques de fabrication

Ce groupe de ventilateurs appartenant à la série légère, décrite antérieurement, nous signalerons uniquement ce qui les différencie

Montage du moteur

Le moteur est accouplé de la façon suivante.

D'un côté, l'arbre du moteur est uni directement au disque central grâce au moyeu.

De l'autre côté, le moteur est fixé, à l'aide d'un support spécial, à l'ouïe d'aspiration de façon à obtenir un démontage facile.

Il est prévu un amortisseur en caoutchouc entre moteur et support.

Moteur électrique

Le moteur employé est du type ouvert (IP20) ou fermé (IP54) classe F, monophasé, 220 V, 50 Hz, de 4 ou 6 pôles, une vitesse, avec condensateur, et protection interne par thermostat.

Dans les modèles 10/10, 12/9, 12/12 y 15/15 il est possible de monter un moteur triphasé, 220/380 V, 50 Hz, de 6 pôles, 1 vitesse, classe F.

Condensateur

Répondant à la NORME VDE, le condensateur est de polypropylène, avec carcase de protection en matière plastique, les bornes sont protégées par un capuchon en caoutchouc.

Il est fixé au ventilateur par un clip en acier.

Raccordement électrique

Il s'effectue à l'aide des bornes montées à cet effet.

Celles-ci sont protégées par un capuchon en plastique.

Recommandations d'emploi

Assurer une bonne entrée d'air par l'ouïe où est fixé le moteur, de façon à éviter un possible échauffement de celui-ci.

Respecter les vitesses limites indiquées par le fabricant du moteur et qui figurent sur la plaque de caractéristiques de celui-ci.

Ne pas utiliser le ventilateur avec refoulement libre, car dans ce cas il se produirait une augmentation importante de l'intensité absorbée.

Le ventilateur ne doit jamais travailler avec de l'air ou dans une ambiance supérieure à 45° C.

Variantes de fabrication

Sur commande, il est possible d'étudier des ventilateurs avec les changements suivants:

- Moteur à 3 vitesses.
- Régulateur de vitesses.

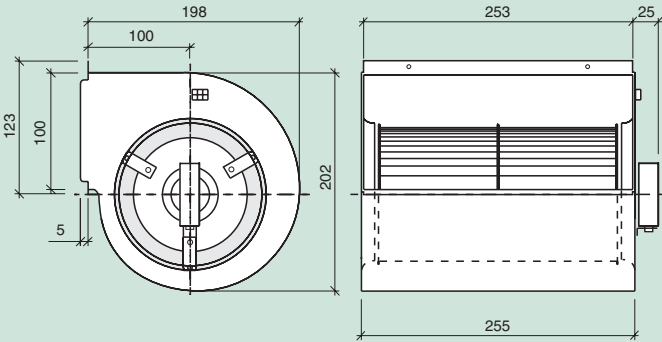

Motor Clase B					Cond.	Tens.	Peso
P_{NOM} CV	P_{NOM} W	N Polos	N (min^{-1})	I_{NOM} A	μF	V.50Hz	Kg
1/20	27	4	1200	0.32	2	230	2.5

1/20 C.V.

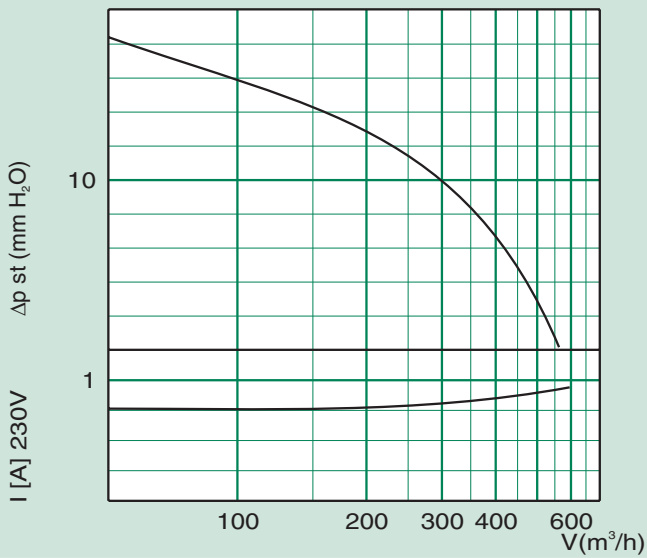

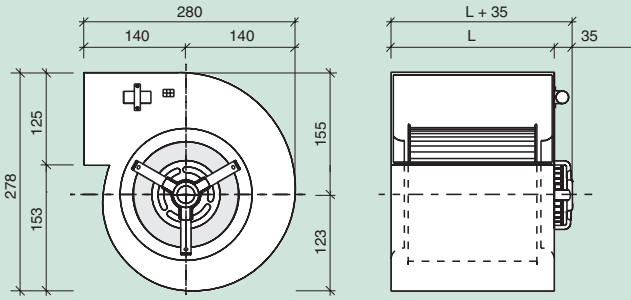

Motor Clase F					Cond.	Tens.
P _{NOM} CV	P _{NOM} W	N Polos	N (min ⁻¹)	I _{NOM} A	μF	V.50Hz
1/5	150	4	1184	1.84	6	230

TAMAÑO	Denominación Métrica	L	Peso Kg
6/5	180 x 150	216	6.5
6/6 *	180 x 185	250	7
6/7	180 x 215	278	7.5

* Bajo pedido

6/5 - 1/5 C.V.

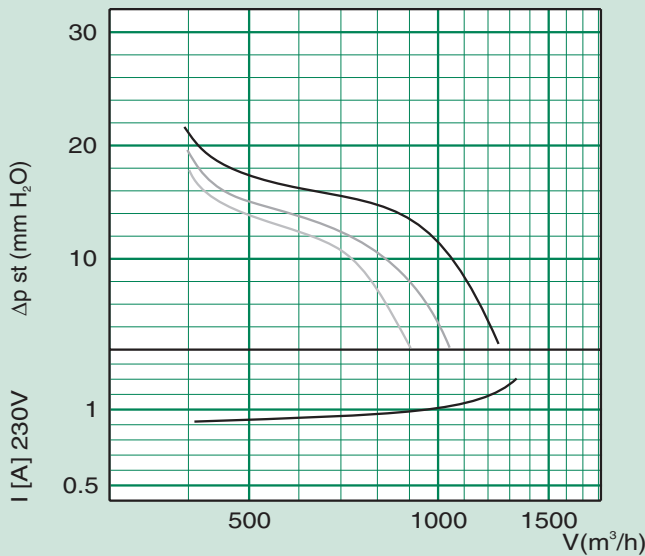

6/6 - 1/5 C.V.

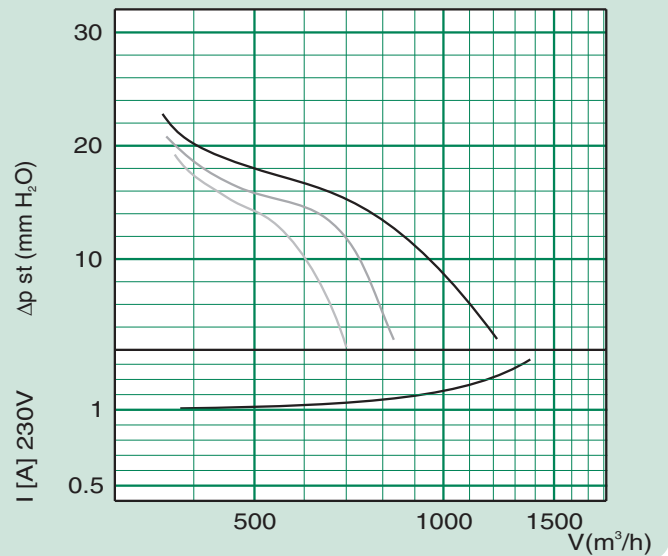

6/7 - 1/5 C.V.

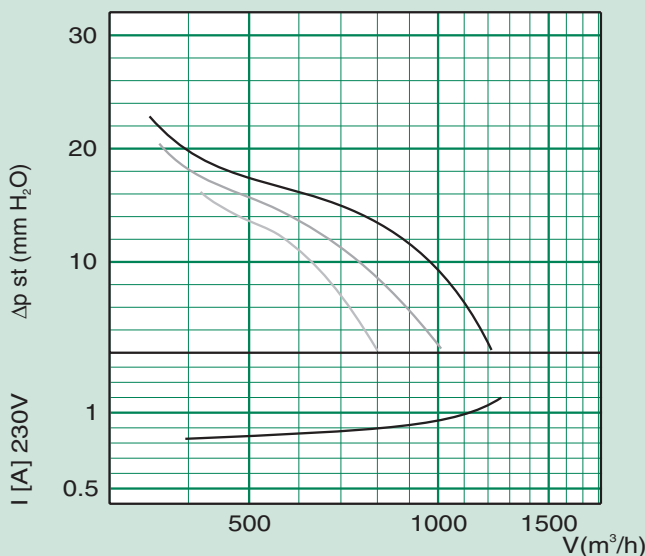

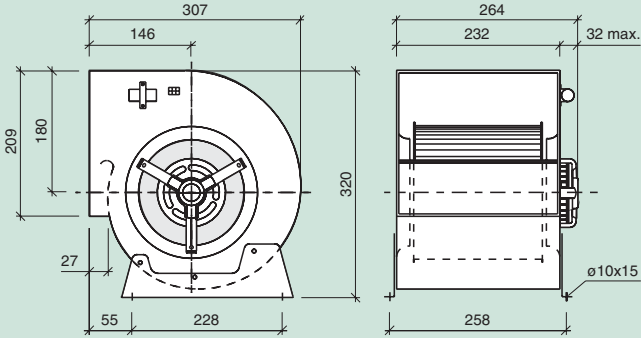

Motor Clase F					Cond.	Tens.	Peso
P_{NOM} CV	P_{NOM} W	N Polos	N (min^{-1})	I_{NOM} A	μF	V.50Hz	Kg
1/10	52	6	820	0.78	4	230	7
1/5	150	4	1184	1.84	6	230	7

1/10 C.V.

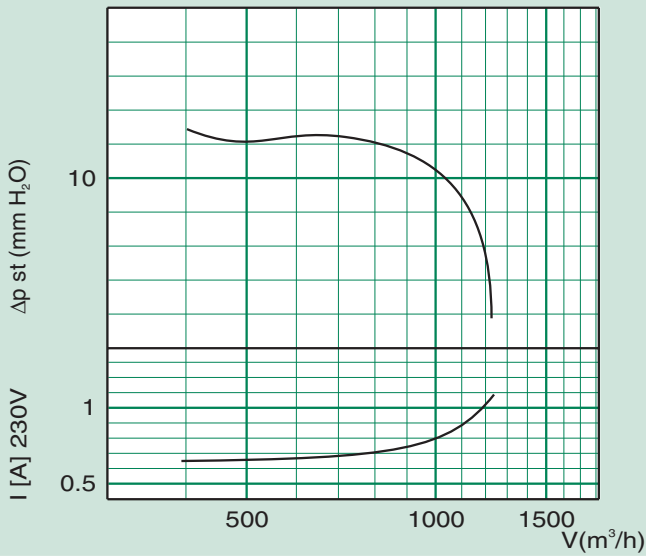

1/5 C.V.

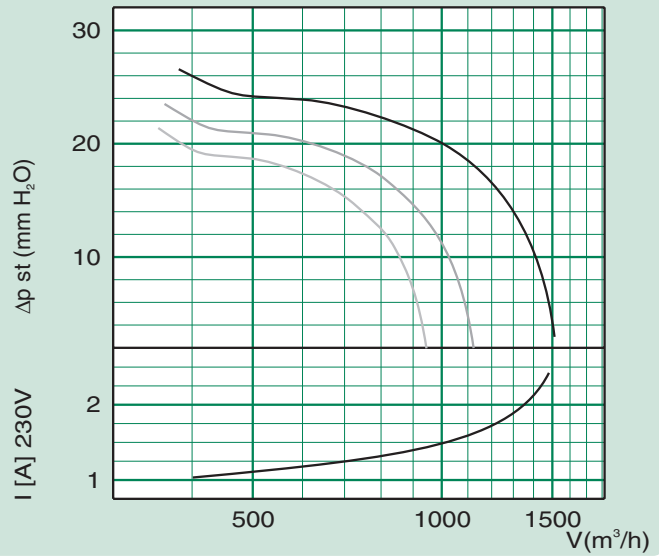

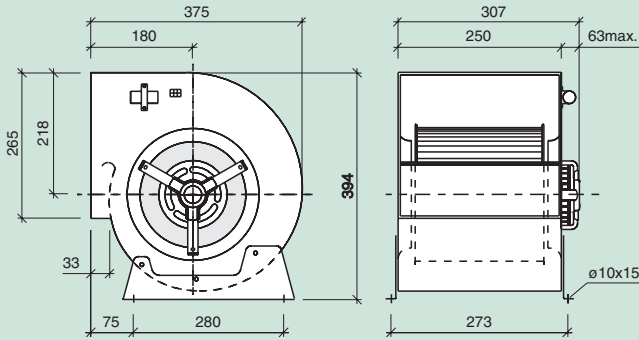

Motor Clase F					Cond.	Tens.	Peso
P_{NOM} CV	P_{NOM} W	N Polos	N (min^{-1})	I_{NOM} A	μF	V.50Hz	Kg
1/5	140	6	850	1.50	5	230	11.2
1/3	237	6	830	2.40	8	230	12.4
1/2	480	4	1250	4.90	10	230	12.9
3/4	600	4	1250	4.70	16	230	13.7

1/5 C.V.

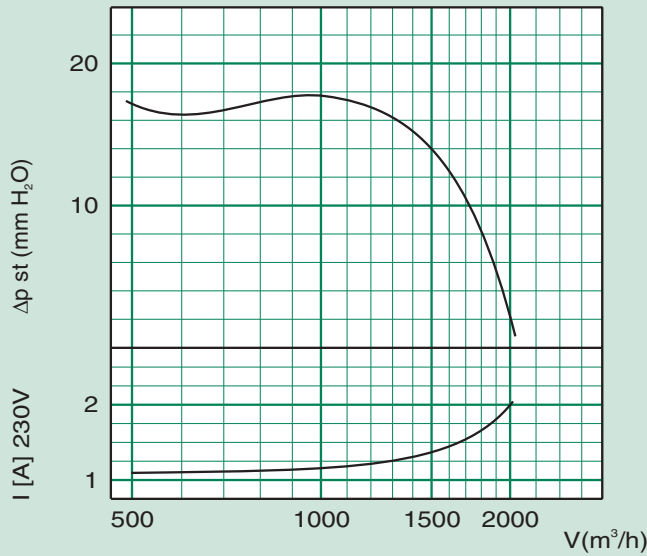

1/3 C.V.

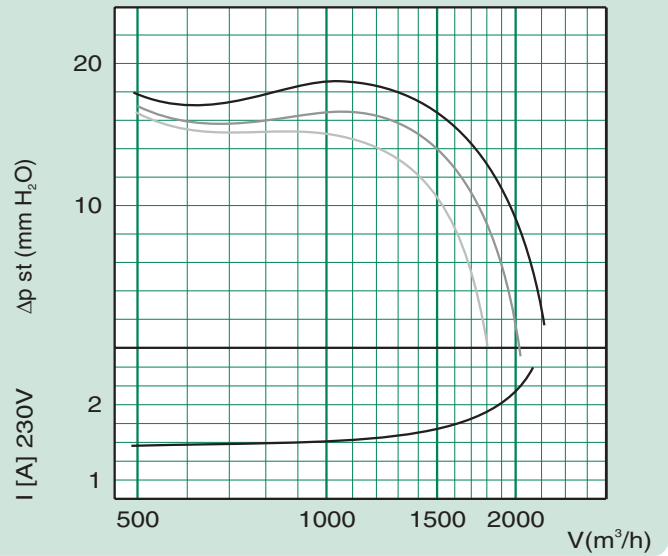

1/2 C.V.

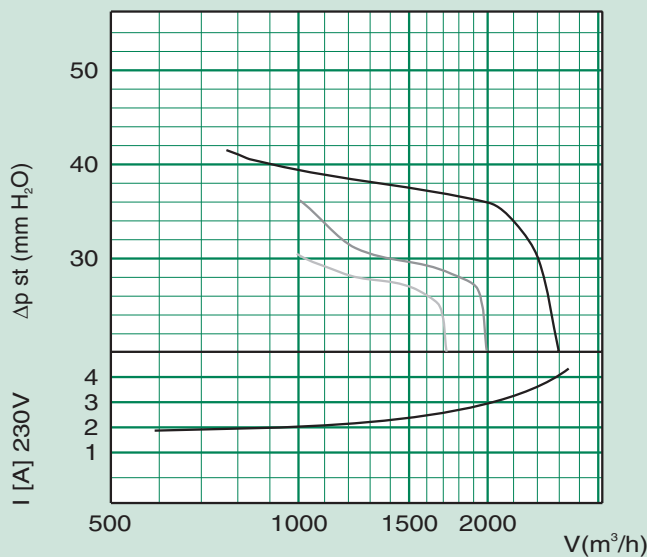

3/4 C.V.

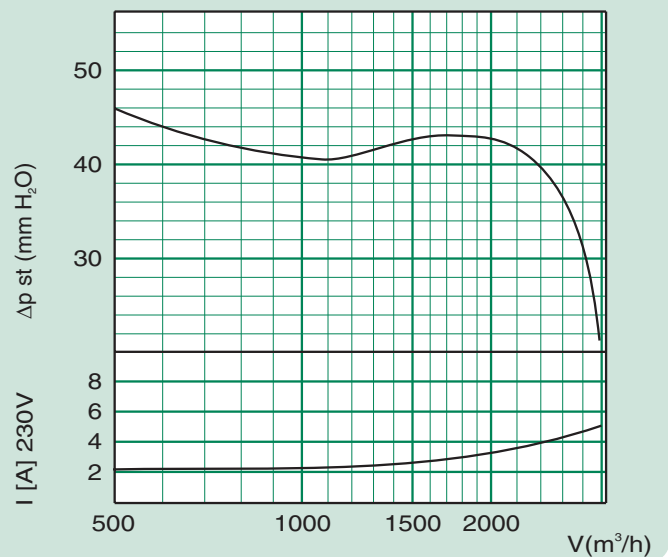

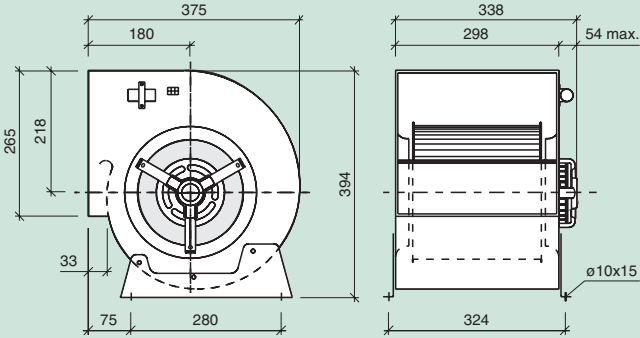

Motor Clase F					Cond.	Tens.	Peso
P_{NOM} CV	P_{NOM} W	N Polos	N (min^{-1})	I_{NOM} A	μF	V.50Hz	Kg
1/5	140	6	850	1.50	5	230	11.5
1/3	237	6	830	2.40	8	230	12.7
1/2	480	4	1250	4.90	10	230	13.2
3/4	600	4	1250	4.70	16	230	14

1/5 C.V.

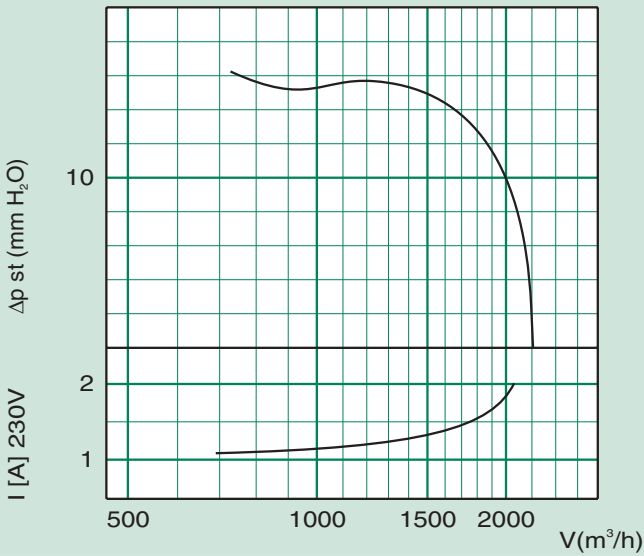

1/3 C.V.

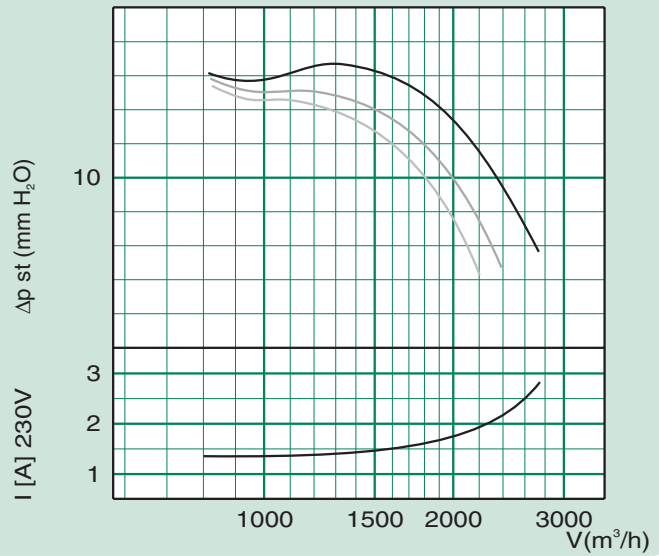

1/2 C.V.

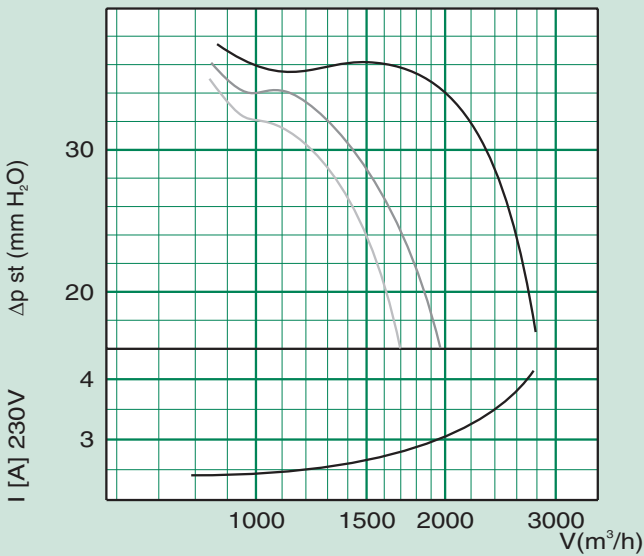

3/4 C.V.

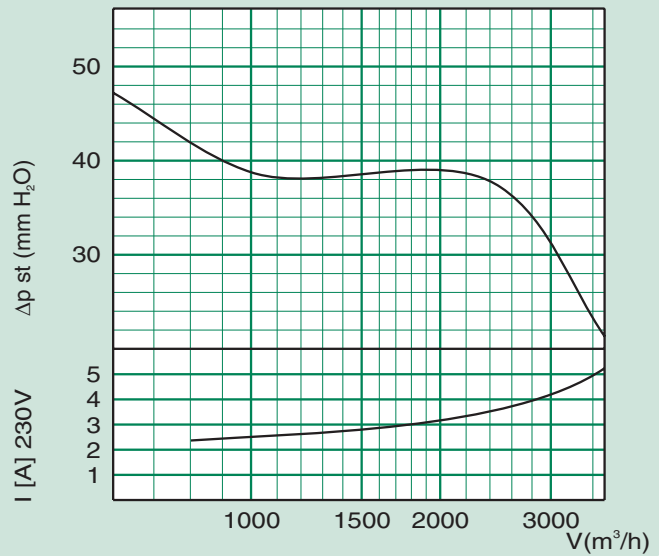

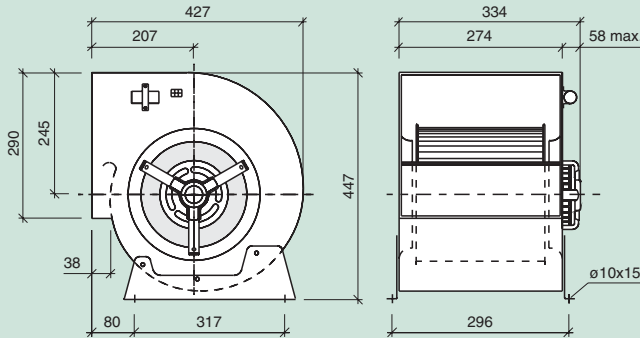

Motor Clase F					Cond.	Tens.	Peso
P_{NOM} CV	P_{NOM} W	N Polos	N (min^{-1})	I_{NOM} A	μF	V.50Hz	Kg
1/3	237	6	830	2.40	8	230	14
1/2	480	4	1250	4.90	10	230	14.5
3/4	600	4	1250	4.70	16	230	15.3

1/3 C.V.

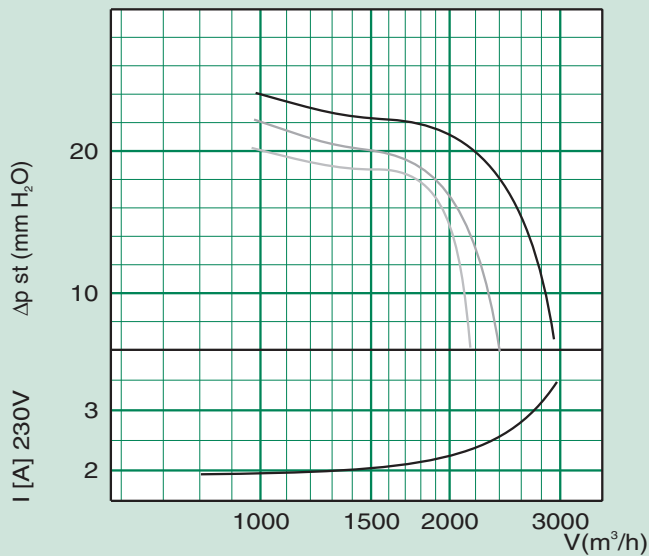

1/2 C.V.

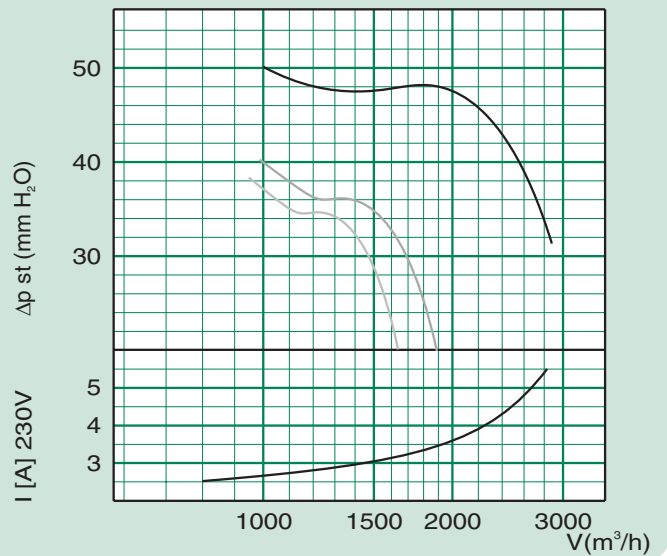

3/4 C.V.

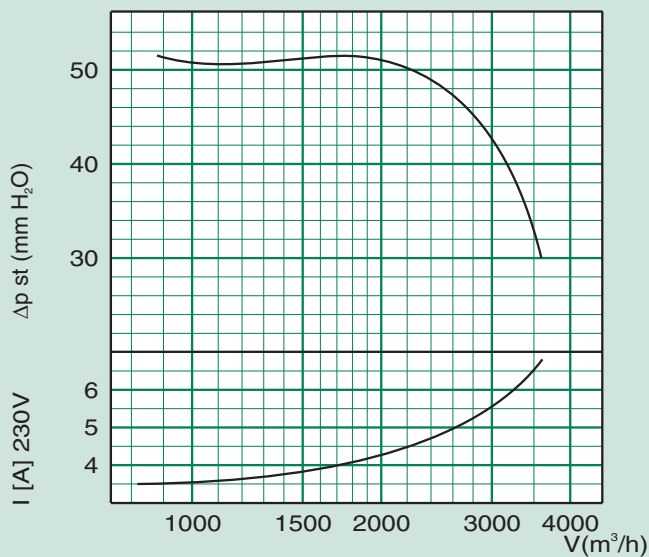

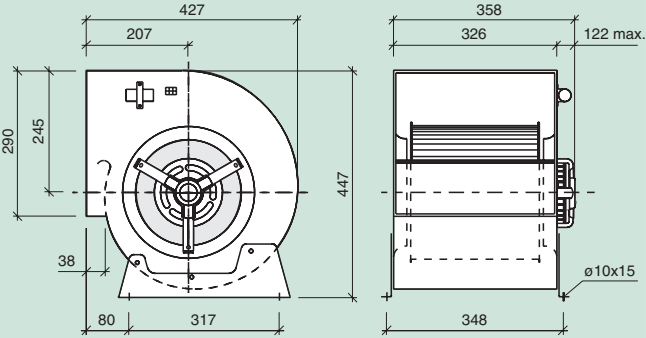

Motor Clase F					Cond.	Tens.	Peso
P _{NOM} CV	P _{NOM} W	N Polos	N (min ⁻¹)	I _{NOM} A	μ F	V.50Hz	Kg
1/3	237	6	830	2.40	8	230	15.2
1/2	480	4	1250	4.90	10	230	15.7
3/4	600	4	1250	4.70	16	230	16.5
3/4	600	6	900	4.30	16	230	21.1
1	765	6	900	5.35	16	230	22.1
1	736	6	900	4.33 2.5	-	230 400	22.1

1/3 C.V.

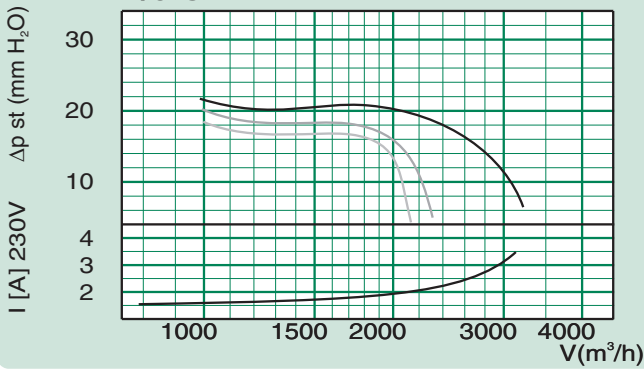

1/2 C.V.

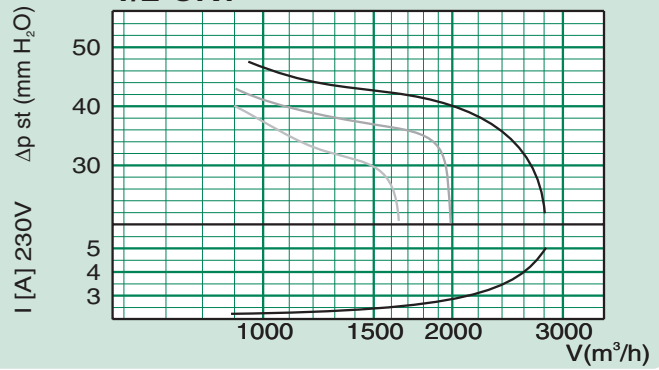

3/4 C.V. 4p

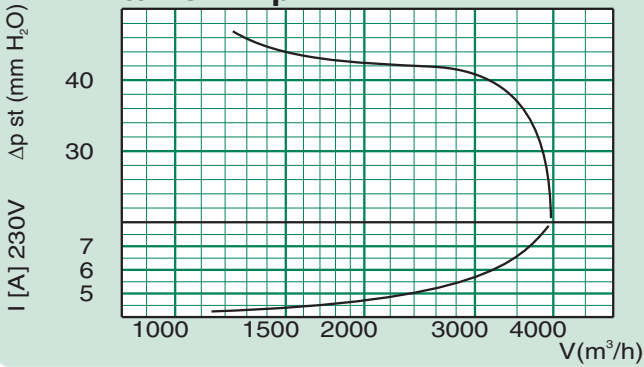

3/4 C.V. 6p

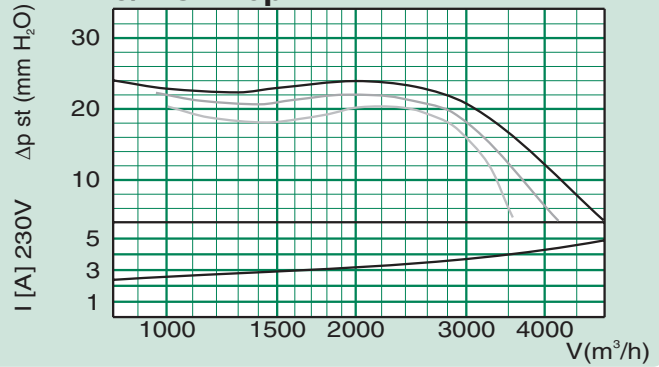

1 C.V.

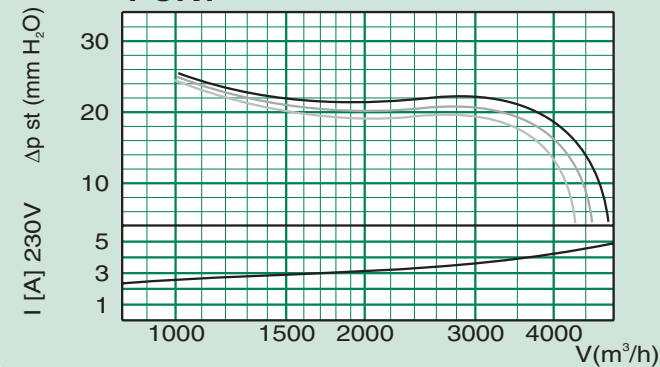

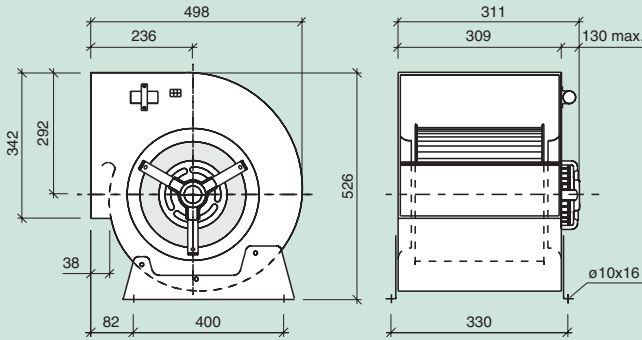

Motor Clase F					Cond.	Tens.	Peso
P _{NOM} CV	P _{NOM} W	N Polos	N (min ⁻¹)	I _{NOM} A	μ F	V.50Hz	Kg
3/4	600	6	900	4.30	16	230	22
1	765	6	900	5.35	16	230	23
1	736	6	900	4.33 2.5	-	230 400	23
1.5	1380	6	900	10.40 6	-	230 400	23.5
1.5	1380	6	900	6.5	20	230	25

3/4 C.V.

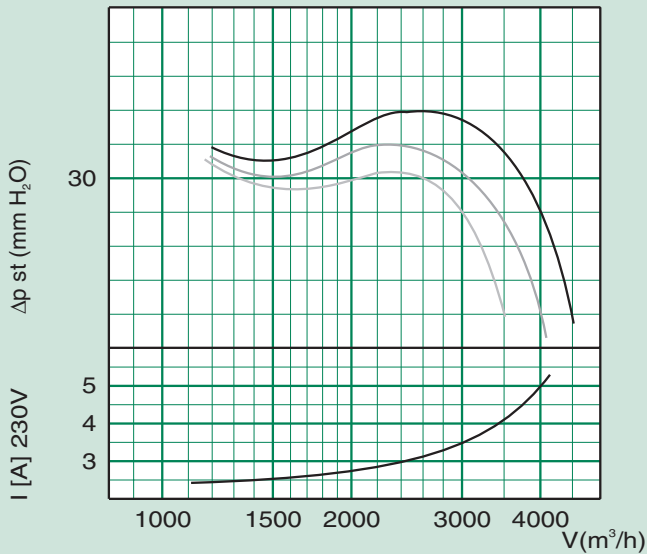

1 C.V.

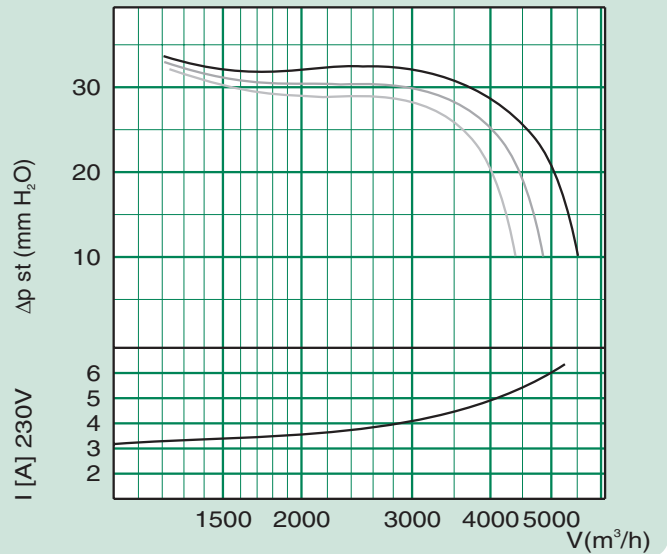

1.5 C.V.

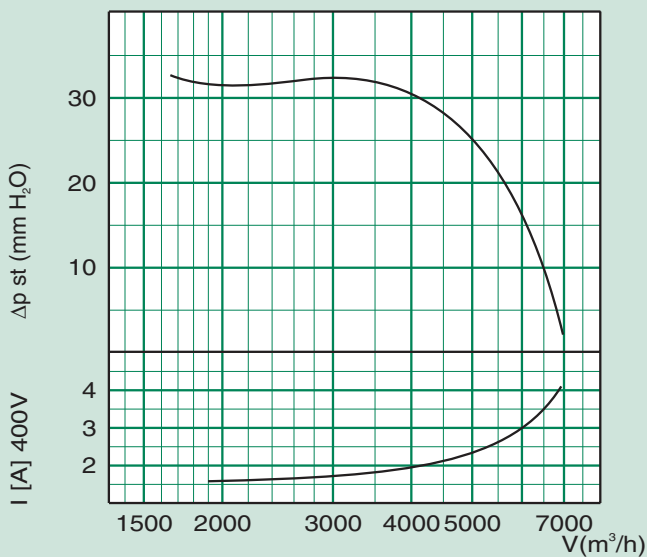

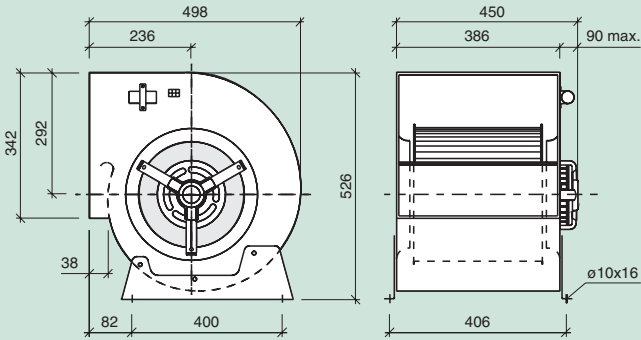

Motor Clase F					Cond.	Tens.	Peso
P_{NOM} CV	P_{NOM} W	N Polos	N (min^{-1})	I_{NOM} A	μF	V.50Hz	Kg
3/4	600	6	900	4.50	14	230	23
1	765	6	900	5.30	16	230	24
1	736	6	900	4.33 2.5	-	230 400	24
1.5	1380	6	900	10.40 6	-	230 400	24.5
1.5	1380	6	900	6.5	20	230	26

3/4 C.V.

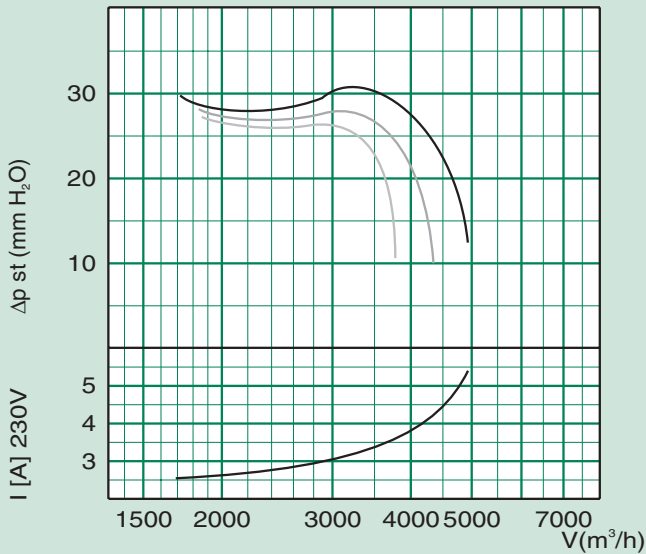

1 C.V.

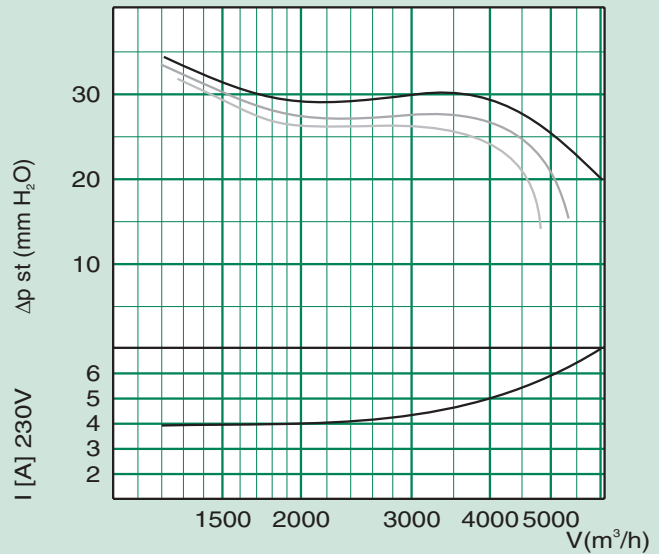

1.5 C.V.

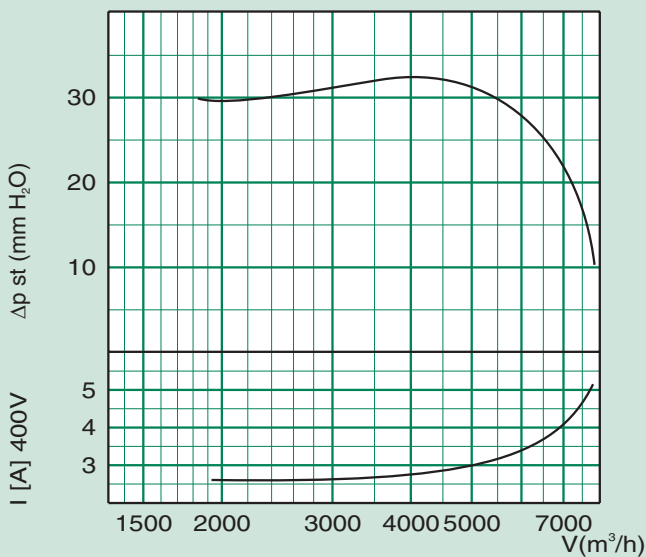

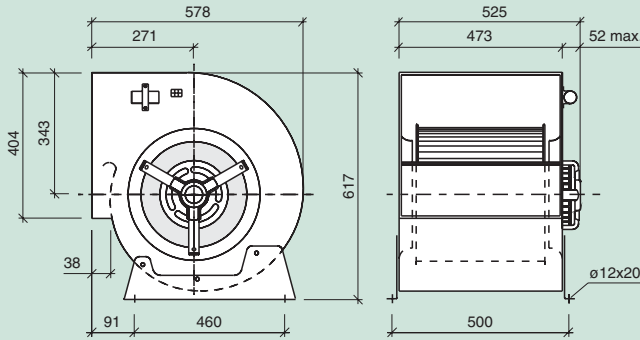

Motor Clase F					Cond.	Tens.	Peso
P _{NOM} CV	P _{NOM} W	N Polos	N (min ⁻¹)	I _{NOM} A	μ F	V.50Hz	Kg
3	2200	6	925	12 7	-	230 400	39

3 C.V.

