



Axial fan condenser



WA range

- Painted casing and corrosion-resistant, stainless steel screws.
- Very low noise 12 and 16 pole models.
- 2-speed, axial fans.
- 2 blowing directions: horizontal or vertical installation as standard.
- Modular product comprising 34 models: 13 types of coils and 4 types of fans.

Heatcraft reserves itself the right to make changes at any time without preliminary notice - Photos non-contractual



Low noise level



7.5  99 kW

FRIGA-BOHN 

HK[®] REFRIGERATION

Market segments



- Bars - Restaurants - Corner shops - Mini-markets

Description

Casing

- Made of galvanized sheet steel, the condensers of the WA range are extremely well protected against corrosion thanks to the UV-resistant, polyester paint coating, as well as the use of white pre-painted, galvanized sheet steel.
- Components (fans, heat-exchanger coil) are fitted with stainless steel screws offering excellent corrosion resistance.

Ventilation

- The condensers of the WA range are equipped with axial fans:
 - Ø 500 mm, 2 speeds:**
 - 04/06P = 1,500/1,000 rpm.
 - 08/12P = 750/500 rpm.
 - Ø 630 mm, 2 speeds:**
 - 04/06P = 1,500/1,000 rpm.
 - 06/08P = 1,000/750 rpm.
 - 08/12P = 750/500 rpm.
 - 16P = 375 rpm.
- 400 V, 3-phase, 50 Hz (50-60 Hz for 08/12P and 12/16P motors), monoblock, external rotor, with incorporated thermal overload protection, IP 54, class F.
- The high-efficiency, profiled fan blades turn at a very low noise level.
- The protection guards are compliant with safety standards.
- 2-speed motor connection: Δ = high speed, Y = low speed.

Coil

- The condensers of the WA range are equipped with a compact, high-efficiency, finned coil composed of staggered, grooved tubes placed in the air flow and with profiled aluminium fins, spacing 2.12 mm, optimizing the heat exchange coefficient.

Designation

WA 39⁽¹⁾ 04/06P⁽²⁾

- (1) Model
 (2) 04/06P = 1,500/1,000 rpm - 06/08P = 1,000/750 rpm
 08/12P = 750/500 rpm - 16P = 375 rpm

Certifications



Advantages

Installation

The unit may be installed in horizontal or vertical position with standard legs.

The coil and fan units may be delivered separately.

Servicing / Maintenance

Fans of the "plug" type for easy maintenance.

External-rotor, axial fans require no specific maintenance.

Kit	Factory
	IRP
	M60
	MM5
	M23*
	M24*
	BXT

Options

Ventilation

- Rotary proximity switch(es).
- Fan 400 V/3/60 Hz.
- Fan 230 V/1/50 Hz - 04/06P - 06/08P - 08/12P.
- Fan 230 V/3/50 Hz - 04/06P.
- Fan 230 V/3/50-60 Hz - 08/12P.

Coil

Blygold Polual XT coil protection.

* Fans not kept on stock.

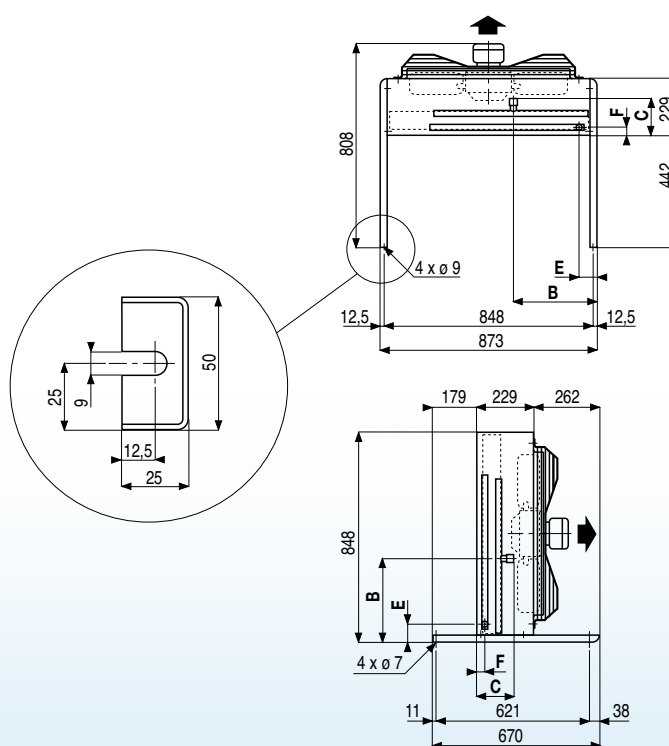
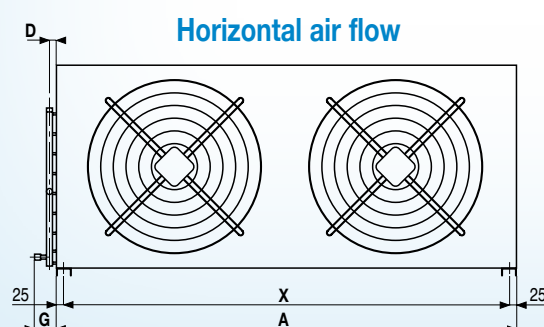
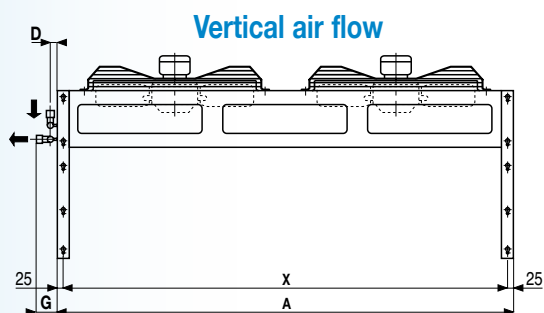

WA ..
04P/06P (1,500/1,000 rpm.)

		WA ..	15	19	22	30	39	44	48	58	67	54	59	81	95	
Capacity	DT1 = 15K	04P (Δ)	kW	12,7	16,5	18,8	25,3	33,0	37,5	38,0	49,6	56,3	62,6	85,2	98,7	
		R404A 06P (Y)	kW	11,6	14,7	16,1	23,1	29,3	32,2	34,7	44,0	48,3	47,1	51,4	70,6	79,1
Surface			m ²	17,5	26,2	34,9	34,9	52,4	69,9	52,4	78,6	104,8	71,5	95,3	107,2	142,9
Circuit volume			dm ³	3	5	6	6	9	12	9	13	18	12	16	18	24
Fan *	Air flow	04P (Δ)	m ³ /h	5970	5630	5320	11950	11270	10630	17920	16900	15940	23200	21300	34800	31950
		06P (Y)	m ³ /h	5040	4650	4280	10070	9310	8550	15110	13960	12820	16600	15100	24900	22650
			Nb x mm	1 x Ø 500	1 x Ø 500	1 x Ø 500	2 x Ø 500	2 x Ø 500	2 x Ø 500	3 x Ø 500	3 x Ø 500	3 x Ø 500	2 x Ø 630	2 x Ø 630	3 x Ø 630	3 x Ø 630
Energy efficiency class		04P (Δ)		E	E	E	E	E	E	E	E	E	E	E	E	E
		06P (Y)		E	E	D	E	E	D	E	E	D	E	E	E	E
Acoustic	Lw (1)	04P (Δ)	dB(A)	83	83	83	86	86	86	88	88	88	93	93	95	95
		06P (Y)	dB(A)	78	78	78	81	81	81	83	83	83	85	85	87	87
	Lp (2)	04P (Δ)	dB(A)	51	51	51	54	54	54	56	56	56	61	61	63	63
		06P (Y)	dB(A)	46	46	46	49	49	49	51	51	51	53	53	55	55
Net weight			kg	36	40	44	63	72	80	92	104	116	93	103	137	152
Circuits			Nb	2	4	4	4	6	8	8	8	8	8	8	12	16
Dimensions	A		mm	730	730	730	1390	1390	1390	2050	2050	2050	1870	1870	2770	2770
	B		mm	240	520	340	340	495	390	390	470	390	470	390	455	455
	C		mm	150	150	150	150	155	155	155	155	155	150	150	160	160
	D		mm	20	25	25	25	30	30	30	30	30	25	25	50	50
	E		mm	55	40	55	55	45	55	55	45	55	45	55	45	60
	F		mm	73	53	34	73	53	34	73	53	34	53	34	53	34
	G		mm	78	81	81	81	88	88	92	88	88	85	85	115	115
	X		mm	680	680	680	1340	1340	1340	2000	2000	2000	1820	1820	2720	2720
Inlet		ODF (4)	1/2"	5/8"	5/8"	3/4"	7/8"	7/8"	7/8"	7/8"	1 1/8"	1 1/8"	1 1/8"	1 1/8"	1 3/8"	1 3/8"
Outlet		ODF (4)	1/2"	5/8"	5/8"	5/8"	7/8"	7/8"	7/8"	7/8"	7/8"	7/8"	1 1/8"	1 1/8"	1 1/8"	1 1/8"

* Ø 500 mm - 400 V/3/50 Hz - Δ : 580 W max - 1,05 A max (3) - Y : 440 W max - 0,71 A max (3) / Ø 630 mm - 400 V/3/50 Hz - Δ : 1950 W max - 3,4 A max (3) - Y : 1400 W max - 2,3 A max (3)

WA ..
06P/08P (1,000/750 rpm.)

		WA ..	41	42	57	65	
Capacity	DT1 = 15K	06P (Δ)	kW	42,6	45,9	68,1	68,9
		R404A 08P (Y)	kW	35,1	37,3	52,6	56,0
Surface			m ²	71,5	95,3	107,2	142,9
Circuit volume			dm ³	12,1	16,2	18,2	24,3
Fan *	Air flow	06P (Δ)	m ³ /h	14190	12690	21280	19030
		08P (Y)	m ³ /h	10460	9410	15690	14110
			Nb x mm	2 x Ø 630	2 x Ø 630	3 x Ø 630	3 x Ø 630
Energy efficiency class		06P (Δ)		D	D	D	D
		08P (Y)		D	D	D	D
Acoustic	Lw (1)	06P (Δ)	dB(A)	83	83	85	85
		08P (Y)	dB(A)	76	76	78	78
	Lp (2)	06P (Δ)	dB(A)	51	51	53	53
		08P (Y)	dB(A)	44	44	46	46
Net weight			kg	89	99	131	146
Circuits			Nb	8	8	12	16
Dimensions	A		mm	1870	1870	2770	2770
	B		mm	470	390	455	455
	C		mm	150	150	160	160
	D		mm	25	25	50	50
	E		mm	45	55	45	60
	F		mm	53	34	53	34
	G		mm	85	85	115	115
	X		mm	1820	1820	2720	2720
Inlet		ODF (4)	1 1/8"	1 1/8"	1 3/8"	1 3/8"	
Outlet		ODF (4)	7/8"	1 1/8"	1 1/8"	1 1/8"	

* Ø 630 mm - 400 V/3/50 Hz - Δ : 450 W max - 1,1 A max (3) - Y : 280 W max - 0,6 A max (3)

- (1) Sound pressure level in dB(A), obtained in compliance with standard NF EN 13487 (parallelepiped reference surface).
- (2) Sound pressure level in dB(A) measured at 10 m, line of sight, on a reflective parallelepiped measurement surface, given for information only. Values measured under nominal operating conditions with clean coils and rated voltage.
- (3) Setting of overload protection levels.
- (4) ODF = Female to receive a tube of the same diameter.

IRP	M60	MM5	M23	M24	BXT
0	0	0	0	-	0

WA ..
08P/12P (750/500 rpm.)

		WA ..	10	13	14	21	26	27	32	37	40	34	36	47	51	
Capacity	DT1 = 15K	08P (Δ)	kW	8,8	10,6	11,3	17,7	21,2	22,6	26,5	31,8	33,8	34,5	36,2	51,8	54,2
		12P (Y)	kW	7,5	8,8	9,1	15,0	17,5	18,3	22,5	26,3	27,4	25,9	26,6	38,8	39,9
Surface			m ²	17,5	26,2	34,9	34,9	52,4	69,9	52,4	78,6	104,8	71,5	95,3	107,2	142,9
Circuit volume			dm ³	3,0	4,5	5,9	5,9	8,9	11,9	8,9	13,4	17,8	12,1	16,2	18,2	24,3
Fan *	Air flow	08P (Δ)	m ³ /h	3160	2880	2660	6330	5760	5310	9500	8640	7960	10200	9060	15300	13590
		12P (Y)	m ³ /h	2450	2230	2030	4890	4450	4070	7340	6680	6100	6780	6060	10170	9090
			Nb x mm	1 x Ø 500	1 x Ø 500	1 x Ø 500	2 x Ø 500	2 x Ø 500	2 x Ø 500	3 x Ø 500	3 x Ø 500	3 x Ø 500	2 x Ø 630	2 x Ø 630	3 x Ø 630	3 x Ø 630
Energy efficiency class		08P (Δ)		C	C	C	C	C	C	C	C	C	C	C	C	C
		12P (Y)		C	B	B	C	B	B	C	B	B	B	B	B	B
Acoustic	Lw (1)	08P (Δ)	dB(A)	64	64	64	67	67	67	69	69	69	75	75	77	77
		12P (Y)	dB(A)	58	58	58	61	61	61	63	63	63	67	67	69	69
	Lp (2)	08P (Δ)	dB(A)	32	32	32	35	35	35	37	37	37	43	43	45	45
		12P (Y)	dB(A)	26	26	26	29	29	29	31	31	31	35	35	37	37
Net weight		kg	36	40	44	63	72	80	92	104	116	89	99	131	146	
Circuits			Nb	2	4	4	4	6	8	8	8	8	8	12	16	
	Dimensions	A	mm	730	730	730	1390	1390	1390	2050	2050	2050	1870	1870	2770	2770
		B	mm	240	520	340	340	495	390	390	470	390	470	390	455	455
		C	mm	150	150	150	150	155	155	155	155	155	150	150	160	160
		D	mm	20	25	25	25	30	30	30	30	30	25	25	50	50
		E	mm	55	40	55	55	45	55	55	45	55	45	55	45	60
		F	mm	73	53	34	73	53	34	73	53	34	53	34	53	34
		G	mm	78	81	81	81	88	88	92	88	88	85	85	115	115
		X	mm	680	680	680	1340	1340	1340	2000	2000	2000	1820	1820	2720	2720
Inlet		ODF (4)	1/2"	5/8"	5/8"	3/4"	7/8"	7/8"	7/8"	1 1/8"	1 1/8"	1 1/8"	1 1/8"	1 3/8"	1 3/8"	
Outlet		ODF (4)	1/2"	5/8"	5/8"	5/8"	7/8"	7/8"	7/8"	7/8"	7/8"	7/8"	1 1/8"	1 1/8"	1 1/8"	

* Ø 500 mm - 400 V/3/50-60 Hz - Δ : 115 W max - 0,3 A max (3) - Y : 75 W max - 0,15 A max (3) / Ø 630 mm - 400 V/3/50-60 Hz - Δ : 260 W max - 0,68 A max (3) - Y : 160 W max - 0,32 A max (3)

WA ..
16P (375 rpm.)

		WA ..	23	24	28	29	
Capacity	R404A DT1 = 15K	16P (Y)	kW	16,6	16,8	24,9	25,1
Surface			m ²	71,5	95,3	107,2	142,9
Circuit volume			dm ³	12,1	16,2	18,2	24,3
Fan *	Air flow	16P (Y)	m ³ /h	3790	3480	5680	5230
			Nb x mm	2 x Ø 630	2 x Ø 630	3 x Ø 630	3 x Ø 630
Energy efficiency class		16P (Y)		B	B	B	B
Acoustic	Lw (1)	16P (Y)	dB(A)	57	57	59	59
	Lp (2)	16P (Y)	dB(A)	25	25	27	27
Net weight			kg	89	99	131	146
Circuits			Nb	8	8	12	16
	Dimensions	A	mm	1870	1870	2770	2770
		B	mm	470	390	455	455
		C	mm	150	150	160	160
		D	mm	25	25	50	50
		E	mm	45	55	45	60
		F	mm	53	34	53	34
		G	mm	85	85	115	115
		X	mm	1820	1820	2720	2720
Inlet		ODF (4)	1 1/8"	1 1/8"	1 3/8"	1 3/8"	
Outlet		ODF (4)	7/8"	1 1/8"	1 1/8"	1 1/8"	

* Ø 630 mm - 400 V/3/50-60 Hz - Y : 90 W max - 0,2 A max (3)

(1) Sound pressure level in dB(A), obtained in compliance with standard NF EN 13487 (parallelepiped reference surface).

(2) Sound pressure level in dB(A) measured at 10 m, line of sight, on a reflective parallelepiped measurement surface, given for information only.

Values measured under nominal operating conditions with clean coils and rated voltage.

(3) Setting of overload protection levels.

(4) ODF = Female to receive a tube of the same diameter.

IRP	M60	MM5*	M23	M24	BXT
0	0	0	-	0	0

* Except for WA .. 12P - 16P