



## Electromotoric Actuators

for valves with 20 mm stroke

**SQX32..**  
**SQX82..**  
**SQX62**

- **SQX32..** operating voltage AC 230 V, 3-position positioning signal
- **SQX82..** operating voltage AC 24 V, 3-position positioning signal
- **SQX62** operating voltage AC 24 V, DC 0...10 V, 4...20 mA, 0...1000 Ω,  
See selection of positioning signals for more details
- **Positioning force 700 N**
- **Direct mounting on valve, no adjustments required**
- **Optional auxiliary switch or potentiometer**
- **Manual adjustment and position indication**
- **SQX82..U and SQX62U are UL approved**

### Use

For operation of Siemens 2-port and 3-port valves of type series VVF.., VVG41.., VXF.. and VXG41.. with 20 mm stroke for water-side control of chilled water, low-temperature hot water and high-temperature hot water in heating, ventilation and air conditioning systems.

## Type summary

Type reference	Operating voltage	Positioning signal	Positioning time (opening and closing)
SQX32.00	AC 230 V	3-position	150 s
SQX32.03			35 s
SQX82.00	AC 24 V		150 s
SQX82.03			35 s
SQX62		DC 0...10 V and / or 0...1000 $\Omega$ , DC 4...20 mA	35 s

Special UL approved versions of SQX82.. and SQX62 available, type suffix U (e.g. SQX62U)

## Accessories

Type reference	Description	For actuators	Mounting location <sup>1)</sup>
ASC9.5	Auxiliary switch	SQX32.., SQX82..	1 x ASC9.5 or 1 x ASZ7.4 or 1 x ASC9.4
ASC9.4	Auxiliary switch pair		
ASZ7.4	Auxiliary switch and potentiometer 1000 $\Omega$		
ASZ6.5	Stem heating AC 24 V	SQX32.., SQX82.., SQX62	1 x ASZ6.5

<sup>1)</sup> Only 1 accessory can be built into the actuator at a time.  
Exception: ASZ6.5 stem heating which is integrated between the actuator and the valve.

## Order

When ordering, please give the quantity, product name, type reference, and any accessories required.

Example: 20 actuators SQX32.00 and  
20 auxiliary switches ASC9.5

## Delivery

Actuators, valves and accessories are supplied in separate packages.

## Spare parts

See overview, section "Replacement parts", page 11.

## Equipment combinations

The actuators are suitable for operation of the following Siemens two-port and three-port valves:

Type reference		DN	PN class	$K_{vs}$ [m <sup>3</sup> /h]	Data sheet
<b>2-port valves VV.. (control or safety shutoff valves)</b>					
VVF21..	flange	25...80	6	1.9...100	N4310
VVF31..	flange	15...80	10	2.5...100	N4320
VVF40..	flange	15...80	16	1.9...100	N4330
VVF41..	flange	50		19 / 31	N4340
VVG41..	thread	15...50		0.63...40	N4363
VVF52..	flange	15...40	25	0.16...25	N4373
<b>3-port valves VX.. (control valves for "mixing" and "diverting" functions)</b>					
VXF21..	flange	25...80	6	1.9...100	N4410
VXF31..	flange	15...80	10	2.5...100	N4420
VXF40..	flange	15...80	16	1.9...100	N4430
VXF41..	flange	15...50		1.9...31	N4440
VXG41..	thread			1.6...40	N4463

See the associated valve data sheets for permissible differential and close-off pressures  $\Delta p_{max}$  and  $\Delta p_s$  of the complete valve-actuator-unit.

Design

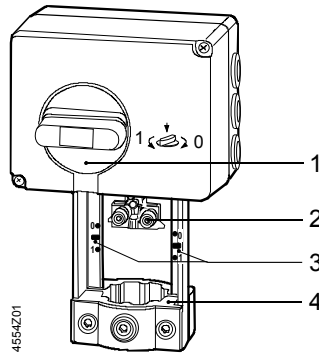

**SQX32..., SQX82..., SQX62:**

- 1 Manual adjuster
- 2 Coupling to valve stem
- 3 Position indication (from 0 to 1)
- 4 Console

**SQX32..., SQX82...:**

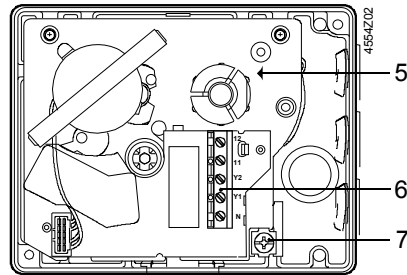

- 5 Mounting position for auxiliary switch or auxiliary switch pair or auxiliary switch and potentiometer
- 6 Terminal strip
- 7 Bonding screw (for SQX32...)

**SQX62:**

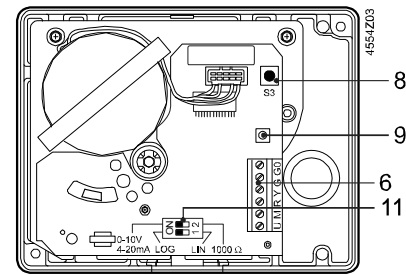

- 8 Button S3 (calibration)
- 9 LED, red / green (operating status indication)
- 11 DIL switches  
switch S1: change-over flow characteristic "**LOG**" / "**LIN**" \*)  
switch S2: change-over signal R "**0-10 V**, **4-20 mA**" / "**1000 Ω**" \*)  
\*) bold print = factory setting

**SQX32..., SQX82..**

3-position positioning signal

The reversible synchronous motor is controlled by a 3-position signal either via terminals Y1 or Y2 and generates the desired stroke by means of a blocking-proof gear train and a gear rack.

- Voltage on Y1: actuator stem extends, valve opens
- Voltage on Y2: actuator stem retracts, valve closes
- No voltage on Y1 and Y2: actuator stem remains in the respective position

**SQX62**

Y, R signals:  
DC 0...10 V and/or  
0...1000 Ω, DC 4...20 mA

The SQX62 is either controlled via terminals Y and/or R. The recorded positioning signals control the synchronous motor by means of microprocessor electronics. This motor generates the desired stroke via a blocking-proof gear train and gear rack.

- Signal Y, R increasing: actuator stem extends, valve opens
- Signal Y, R decreasing: actuator stem retracts, valve closes
- Signal Y, R constant: actuator stem remains in the respective position

For operation with frost protection, see page 4



Motor protective function

The motor protective function effectively prevents a thermal overload of the Synchron motors in swinging control circuits or highly dynamic control. The function is enabled when the cumulative switch-on period for the Synchron motor exceeds a value of 200 seconds (=33%) over the last 10 minutes. The enabled motor protective function limits further switch-on period to S3 33% per EN60034-1 (2 sec. pause / 1 sec. drive). The actuator automatically returns to standard operation, when the conditions for the protective function is no longer pending.

Selection of flow characteristic (S1)



Via DIL switch S1 the flow characteristics can be changed from "equal percentage" (factory setting, S1 = ON) to "linear".

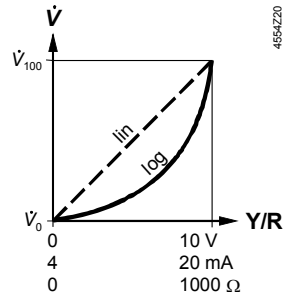

<b>DIL switch S1</b>	factory setting ON	 4554Z21	 4554Z22
<b>Flow characteristics</b>	"equal percentage"	log	"linear" lin

Relationship between the Y, R signals and the volumetric flow:



Selection of positioning signals (S2)



<b>DIL switch S2</b>	factory setting ON	 4554Z11	 4554Z12
<b>Positioning signal Y</b>	DC 0...10 V		DC 0...10 V
<b>Signal R</b>		DC 4...20 mA	0...1000 Ω <sup>1)</sup>
<b>Position / stroke</b>	The Y positioning signal is valued.	The R signal is valued.	Maximum selection of signals Y and R, i.e. the higher signal is valued.
<b>Position feedback U</b>	DC 0...10 V	DC 4...20 mA	DC 0...10 V

<sup>1)</sup> Use with 0...1000 Ω frost protection monitor, e.g. QAF21..., QAF61..., QAF81.. or frost protection thermostat, see connection diagrams for details

Calibration SQX62

In order to determine the stroke positions 0 % and 100 % in the valve, calibration is recommended on initial commissioning. The minimum stroke of the valve is 15 mm. The LED does not indicate a calibration error when the stroke is < 15 mm. The stem extends to the maximum position with the maximum positioning signal DC 10 V.

**Prerequisites**

- Mechanical coupling of the actuator SQX62 with valve
- AC 24 V supply
- Housing cover removed

**Calibration**

<ol style="list-style-type: none"> <li>1. Pressing button S3 starts calibration</li> <li>2. Actuator moves to "0 %" stroke position (valve closed)</li> <li>3. Actuator moves to "100 %" stroke position (valve open)</li> <li>4. Measured values saved in microprocessor</li> </ol>	green LED flashes position feedback U inactive
--	---





**Normal operation**

5. Actuator moves to the position as indicated by signals Y or R	green LED is lit permanently, position feedback U active, the values correspond to the actual positions
--	--

A flashing red LED indicates a calibration error.  
The calibration can be repeated any number of times.

Indication of operating state SQX62

The two-color LED display indicating operating status can be viewed by opening the cover of the electronics module.

LED	Indication	Function	Remarks, troubleshooting
Green	Lit 	Control mode	Automatic operation; everything o.k.
	Flashing 	Calibration	Wait until calibration is finished (green or red LED will be lit)
Red	Lit 	Internal error	Troubleshooting, eventually replace actuator
	Flashing 	Calibration error	Troubleshooting, recalibrate (operate button S3 1x)
Both	Dark 	No power supply Electronics faulty	Check mains network, check wiring Replace actuator

As a general rule, the LED can assume only the states shown above (continuously red or green, flashing red or green, or off).

### Features and advantages SQX..

- Maintenance-free, electromotoric actuator
- Reversible synchronous motor
- Blocking-proof gear train with self-lubricating porous bearings
- Load-dependent switch-off in stroke limit positions
- Manual adjustment with automatic reset to control mode

### Accessories

Auxiliary switch **ASC9.5:**

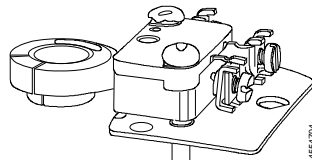

Adjustable switching point

Auxiliary switch with potentiometer **ASZ7.4:**

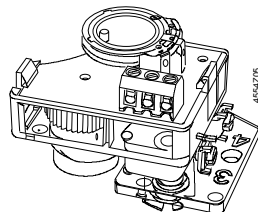

Adjustable switching point

Auxiliary switch pair **ASC9.4:**

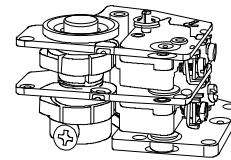

Adjustable switching point

Stem heating **ASZ6.5:**

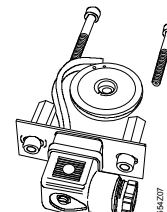

For media below 0 °C.  
Mounting between valve and actuator

See section "Technical data" (page 7) for more information.

### Engineering notes

Conduct the electric connections in accordance with local regulations on electric installations as well as the internal or connecting diagrams.

Caution 

**Safety regulations and restrictions designed to ensure the safety of people and property must be observed at all times!**

Caution 

**For media below 0 °C the ASZ6.5 stem heating is required to keep the valve from freezing. For safety reasons the stem heating is designed for an operating voltage of AC 24 V / 30 W.**

**For this case, do not insulate the actuator console and the valve stem, as air circulation must be ensured. Do not touch the hot parts without prior protective measures to avoid burns.**

**Non-observance of the above may result in accidents and fires!**

Admissible temperatures refer to "Technical data", page 7

If an auxiliary switch is required, its switching point should be indicated on the plant schematic.

3-position control

Every actuator must be driven by a dedicated controller (refer to "Connection diagrams", page 9).

## Mounting notes

The mounting/operating instructions are printed on the rear of the actuator housing. Accessory instructions are located in the respective accessory's packaging.

Accessories	Installation instructions	Accessory	Mounting instructions
<b>ASC9.5</b>	G4506.7   4 319 5557 0	<b>ASZ6.5</b>	M4563.7   4 319 5564 0
<b>ASC9.4</b>	G4506.5   4 319 5537 0		
<b>ASZ7.4</b>	G4506.6   4 319 5538 0		

Orientation

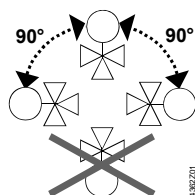

## Commissioning notes

During commissioning, check the wiring, conduct a functional check and calibration (SQX62, refer to page 4). Additionally, check or make the required settings at the auxiliary switch or the auxiliary switch pair.

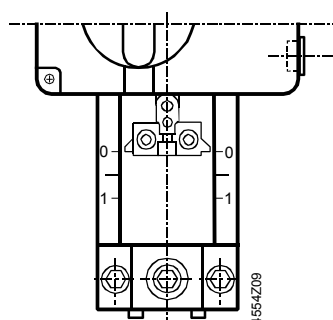

Coupling fully retracted

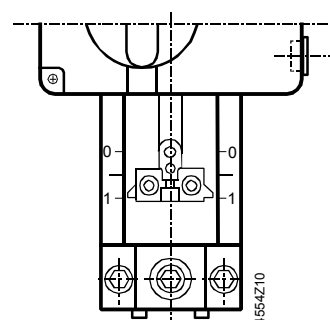

Coupling fully extended

Manual adjustment

Switch off positioning signal. If the manual adjuster is turned clockwise to the end position, the valve is closed (stroke = 0 %).

On pending controller signals, the actuator always moves to the preselected position as soon as the manual adjustment button is released.

## Maintenance notes

The SQX.. actuators are maintenance-free.

When servicing the actuator:

- Switch off pump and power supply
- Close the main shutoff valve in the pipework
- Release pressure in the pipes and allow them to cool down completely
- If necessary, disconnect electrical connections from the terminals

The actuator must be correctly fitted to the valve before recommissioning.

Recommendation: trigger calibration (SQX62, refer to page 4).

## Repair

Cover, control unit and the electromotor can be replaced. Please contact your local Siemens branch office for details.

## Disposal



The device contains electrical and electronic components and must not be disposed of together with domestic waste. This applies in particular to the PCB.

Legislation may demand special handling of certain components, or it may be sensible from an ecological point of view.

**Current local legislation must be observed.**

## Warranty

The technical data relating to specific applications are valid only in conjunction with the valves listed in this Data Sheet under "Equipment combinations", page 2.

**The use of the actuators in conjunction with third-party valves invalidates all claims under Siemens Switzerland Ltd / HVAC Products warranty.**

## Technical data

		SQX32.00 SQX32.03	SQX82.00 SQX82.03	SQX62
Power supply	Operating voltage	AC 230 V ± 15 %	AC 24 V ± 20 %	
	Frequency	50 / 60 Hz		
	Power consumption at 50 Hz	SQX32.00: 3.5 VA SQX32.03: 6.5 VA	6.5 VA	8 VA
	End switches switching capacity, terminals 11 or 12	AC 250 V, 5 A resistive, 1 A inductive	AC 24 V, 5 A resistive, 1 A inductive	
Signal inputs	Terminals Y1, Y2	3-position		
	Terminal Y <sup>1)</sup>		Voltage Current	DC 0...10 V max. 0.1 mA / 5 nF
	Terminal R <sup>1)</sup>		Current Max. impedance Resistance	DC 4...20 mA 250 Ω / 5 nF 0...1000 Ω
Position feedback	Terminal U <sup>2)</sup>		Voltage Current	DC 0...10 V, max. 9.7 V ± 0,2 V DC 4...20 mA, max. 20 mA
	Parallel operation of actuators			max. 10
Operating data	Positioning time at 50 Hz	SQX32.00: 150 s SQX32.03: 35 s	SQX82.00: 150 s SQX82.03: 35 s	35 s
	Positioning force	700 N		
	Nominal stroke	20 mm		
	Admissible medium temperature	in assembled valve -25...150 °C		
Electrical connections	Cable entry	3 openings Ø20.5 mm (for M20)		
Norms and Standards	CE-conformity to EMC directive	2004/108/EC		
	Immunity	EN 61000-6-2 Industrial <sup>3)</sup>		
	Emissions	EN 61000-6-3 Residential		
	Low Voltage Directive	2006/95/EC		
	Electrical safety	EN 60730-1		
	Protection class to EN 60730	Class I	Class II	
	Pollution degree	to EN 60730, 2		

	SQX32.00 SQX32.03	SQX82.00 SQX82.03	SQX62
Housing protection Upright to horizontal	IP54 to EN 60529		
Conform with UL standards		UL 873 <sup>4)</sup>	
Environmental compatibility	ISO 14001 (Environment) ISO 9001 (Quality) SN 36350 (Environmentally compatible products) RL 2002/95/EG (RoHS)		
Dimensions / Weight	Dimensions	refer to "Dimensions"	
	Weight	1.7 kg (with packaging)	
Materials	Actuator housing and console	Die-cast aluminium	
	Housing box and manual adjuster	Plastic	

Caution 

- <sup>1)</sup> If a DC 4...20 mA positioning signal is connected to terminal R, terminal Y cannot be used simultaneously! SQX62.. has a built in motor protection, see page 3 for details
- <sup>2)</sup> The position feedback U corresponds to the stroke position.
- <sup>3)</sup> Transformer 160 VA (e.g. Siemens 4AM 3842-4TN00-0EAO) for AC 24 V actuators
- <sup>4)</sup> Type suffix U, e.g. SQX62U or SQX82.00

### Accessories

ASC9.5 auxiliary switch	Switching capacity	AC 250 V, 10 A resistive, 3 A inductive	
ASC9.4 auxiliary switch pair	Switching output of one auxiliary switch		
ASZ7.4 auxiliary switch and potentiometer (as one unit)	Switching output of auxiliary switch		
	Change of overall resistance of the potentiometer at nominal stroke 20 mm	0...1000 Ω (corresponds to 0...100 % stroke)	
ASZ6.5 stem heating	Operating voltage	AC 24 V	
	Power consumption	30 W	

### General environmental conditions

	Operation EN 60721-3-3	Transport EN 60721-3-2	Storage EN 60721-3-1
Environmental conditions	Class 3K5	Class 2K3	Class 1K3
Temperature	-15...+50 °C	-30...+65 °C	-15...+50 °C
Humidity	5...95 % rh	< 95 % rh	5...95 % rh

### Internal diagrams

SQX32..  
SQX82..

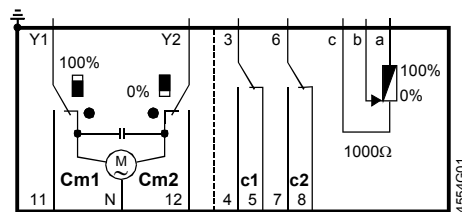

**SQX32..**

AC 230 V, 3-position

- |        |  |
|--------|--|
| Cm1    | end switch 100 %                                     |
| Cm2    | end switch 0 %                                       |
| c1     | auxiliary switch ASC9.5                              |
| c1     | } auxiliary switch pair ASC9.4                       |
| c2     |  |
| c1     | } auxiliary switch and potentiometer (1000 Ω) ASZ7.4 |
| 1000 Ω |  |

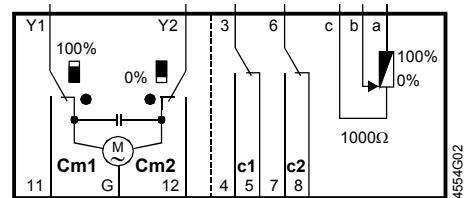

**SQX82..**

AC 24 V, 3-position

Possible mounting location for SQX32.., SQX82.. accessories:

- 1 auxiliary switch ASC9.5 **or**
- 1 auxiliary switch pair ASC9.4 **or**
- 1 auxiliary switch and potentiometer (as one unit) ASZ7.4 **and**
- 1 **additional** stem heating ASZ6.5



Connection terminals  
**SQX62**

AC 24 V, DC 0...10 V and/or 0...1000 Ω, DC 4...20 mA

- G0** — System neutral (SN)
- G** — System potential (SP)
- Y** — Positioning signal for DC 0...10 V signal
- R** — Signal for DC 4...20 mA signal or 0...1000 Ω (signal type is defined at DIL switch S2!)
- M** — Measuring neutral
- U** — Position feedback U = DC 0...10 V when Y = DC 0...10 V resp. R = 0...1000 Ω or U = DC 4...20 mA when R = DC 4...20 mA

**Connection diagrams**

**SQX32..**

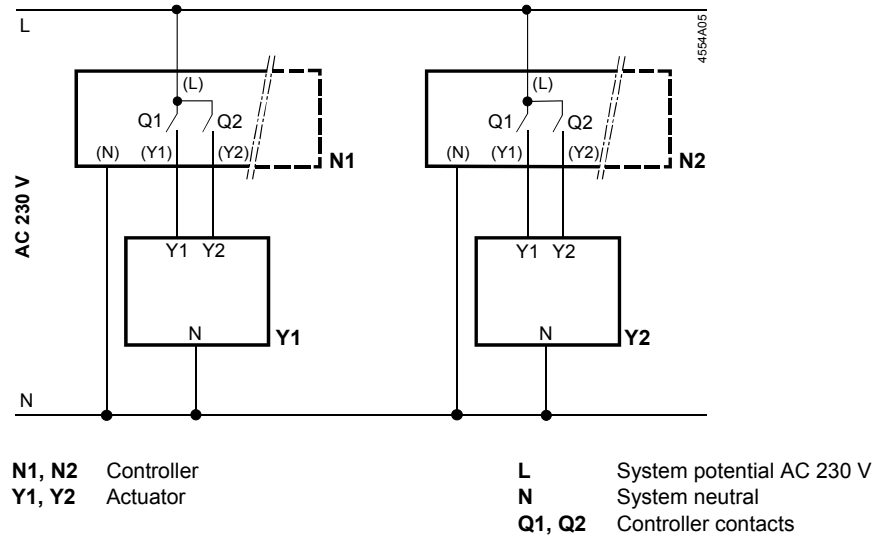

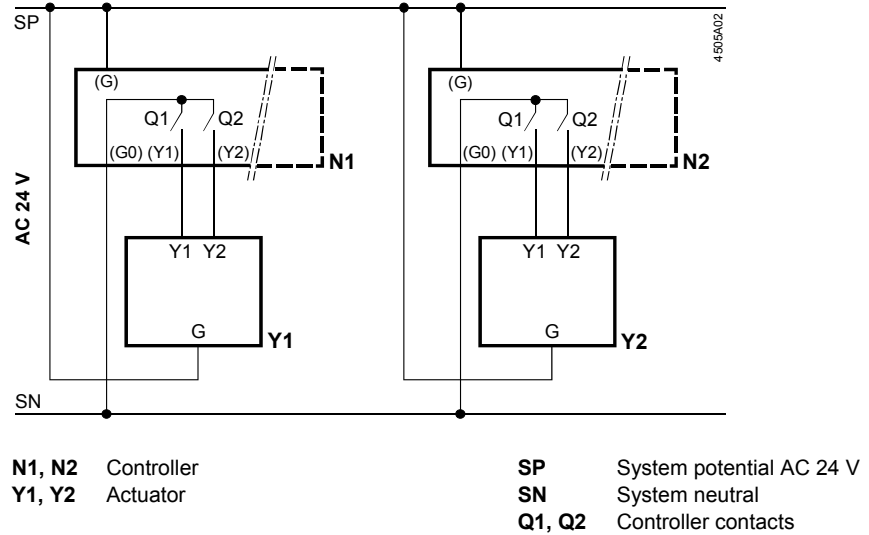

**SQX82..**

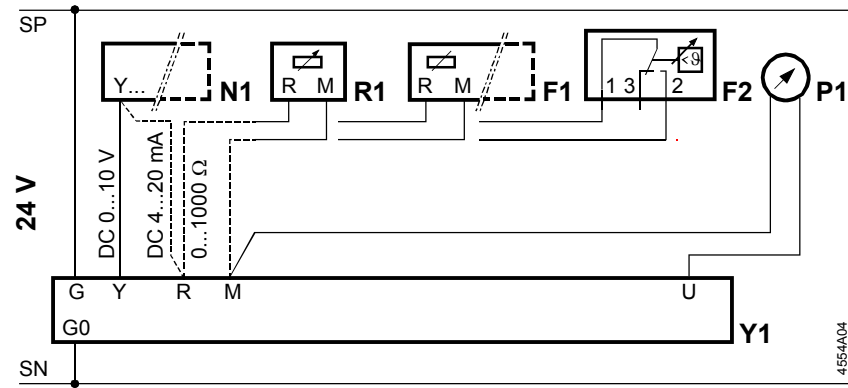

The connection diagram shows all possible connections.  
The amount and type of connection depends on the plant.



- Y1** Actuator
- N1** Controller
- F1** Frost protection monitor with 0...1000 Ω output
- F2** Frost protection thermostat  
Terminal: 1 – 3 frost hazard / sensor is interrupted (thermostat closes with frost)  
          1 – 2 normal operation
- P1** Position indicator
- R1** Position transmitter with 0...1000 Ω potentiometer
- SP** System potential AC 24 V
- SN** System neutral

<b>DIL switch S2</b>	factory setting ON	 4554Z11	 4554Z12
<b>Positioning signal Y</b>	DC 0...10 V		DC 0...10 V
<b>Signal R</b>		DC 4...20 mA	0...1000 Ω <sup>1)</sup>
<b>Position / stroke</b>	The Y positioning signal is valued.	The R signal is valued.	Maximum selection of signals Y and R, i.e. the higher signal is valued.
<b>Position feedback U</b>	DC 0...10 V	DC 4...20 mA	DC 0...10 V

<sup>1)</sup> Use with frost protection monitor, e.g. QAF21..., QAF61..., QAF81.. or frost protection thermostat

**Dimensions**

Dimensions in mm

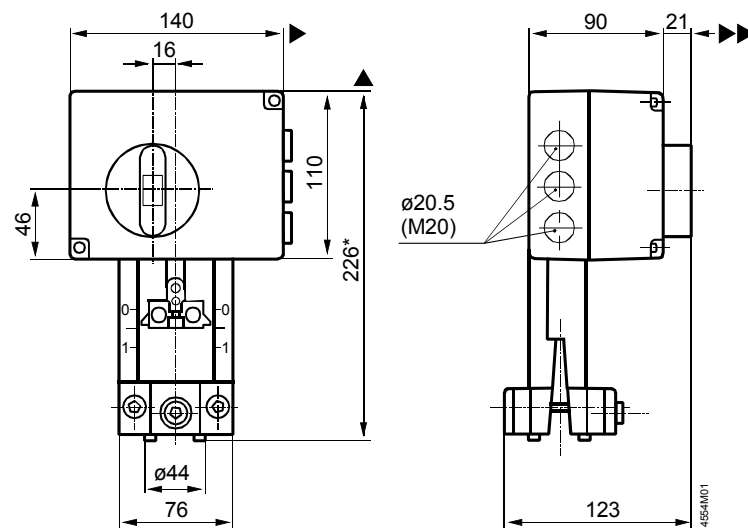



- \* Actuator height from valve
- ▶ > 100 mm Minimum mounting distance to wall or ceiling, for mounting, connection, operation, maintenance etc.
- ▶▶ > 200 mm

## Replacement parts

---

Order numbers for replacement parts

	Cover	Motor <sup>1)</sup>	Control unit
<b>Actuator</b>			
<b>SQX32.00</b>	410455758	475255698	466856218
<b>SQX32.03</b>	410455758	475255708	466856228
<b>SQX82.00</b>	410455758	475255878	466856418
<b>SQX82.03</b>	410455758	475255818	466856418
<b>SQX62</b>	410455758	475255628	466856668

<sup>1)</sup> Synchronous motor including cable, connector and gear

